

- NOTES:
1. ALL TOLERANCES ARE RSS (4 SIGMA).
 2. ALL Z STACK UP HEIGHT ESTIMATES ARE BASED ON PRE SMT BALL HEIGHT.
 3. MARK KEEP IN ZONE. NO COMPONENTS ALLOWED.
 4. NOMINAL PACKAGE MASS ESTIMATE = 29.4 GRAMS. ACTUAL MASS MAY VARY DUE TO MANUFACTURING PROCESS.
 5. ALL Z-HEIGHT RELATED DIMENSIONS ARE BASED ON LIMITED SAMPLING DATA.
 6. LAND SIDE COMPONENT KEEP IN ZONE.

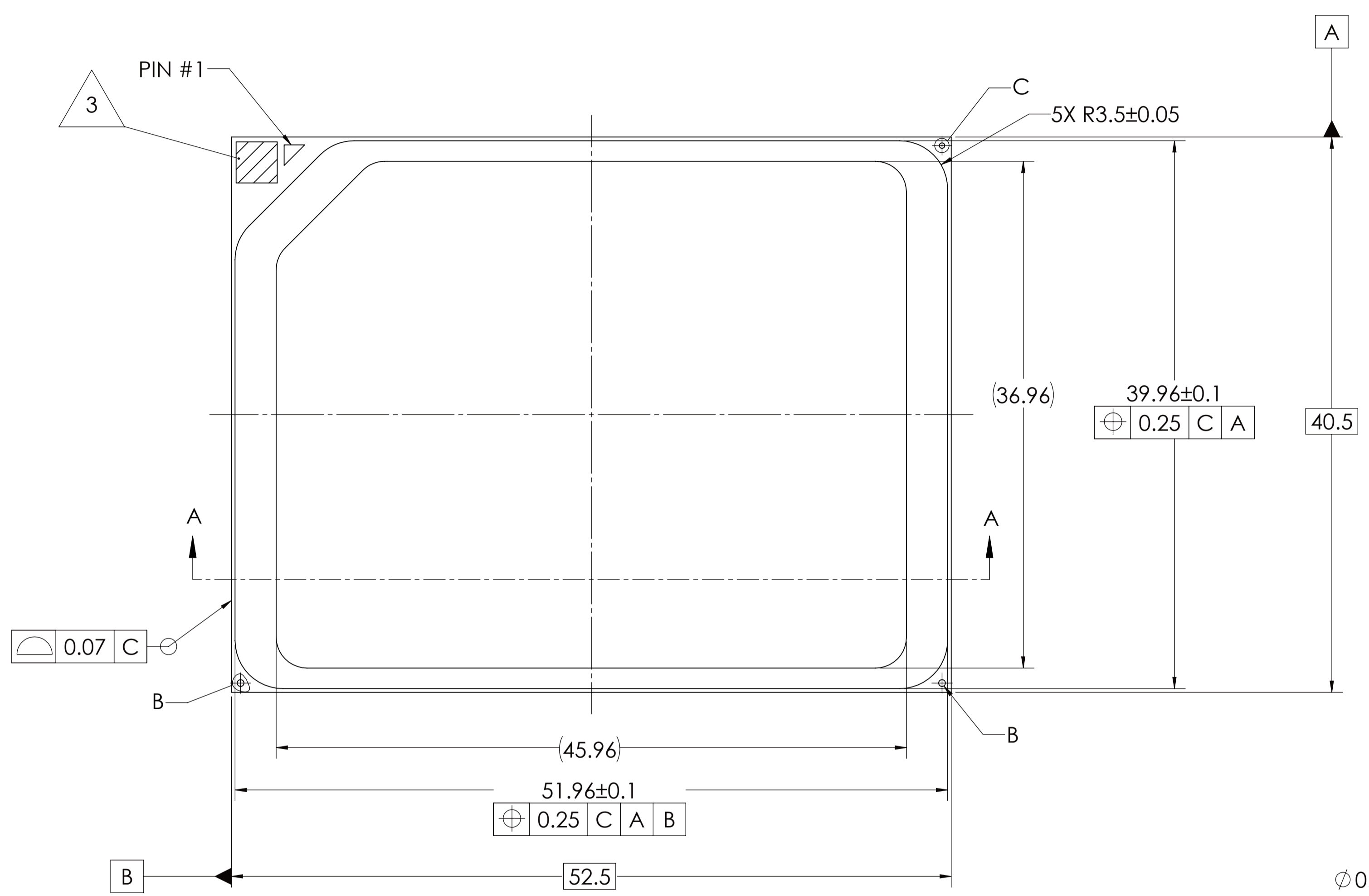

TOP VIEW

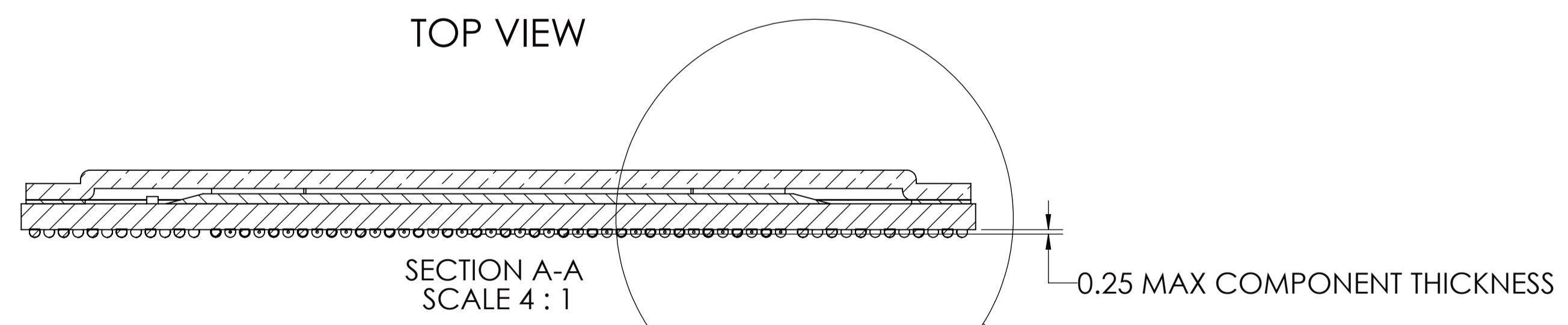

SECTION A-A
SCALE 4 : 1

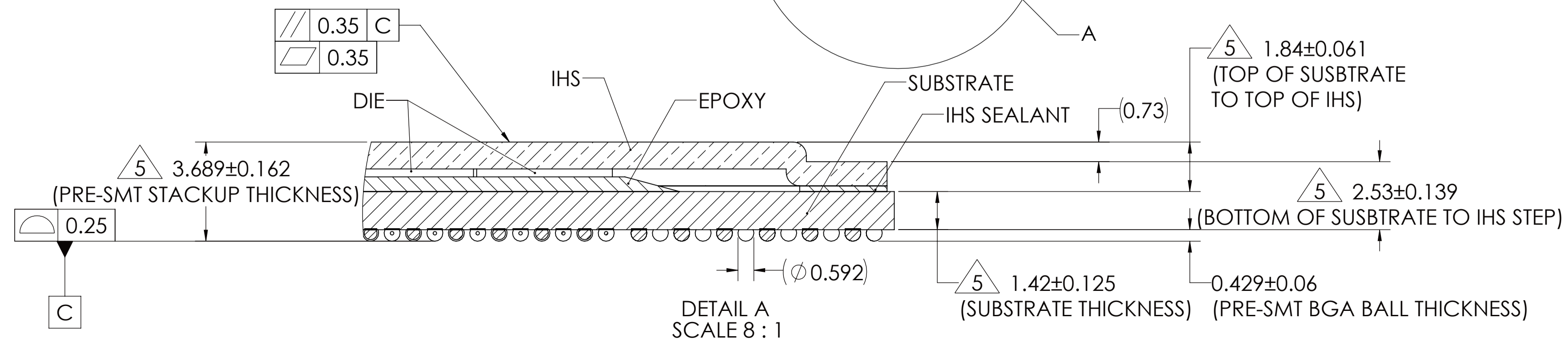

DETAIL A
SCALE 8 : 1

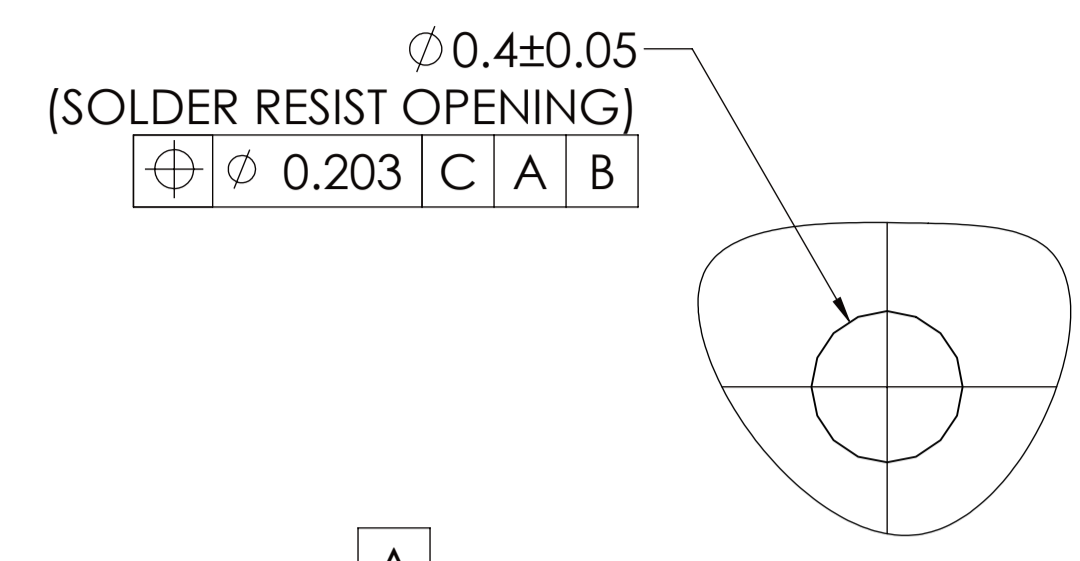

DETAIL C
SURFACE ALIGNMENT FIDUCIAL
SCALE 50 : 1

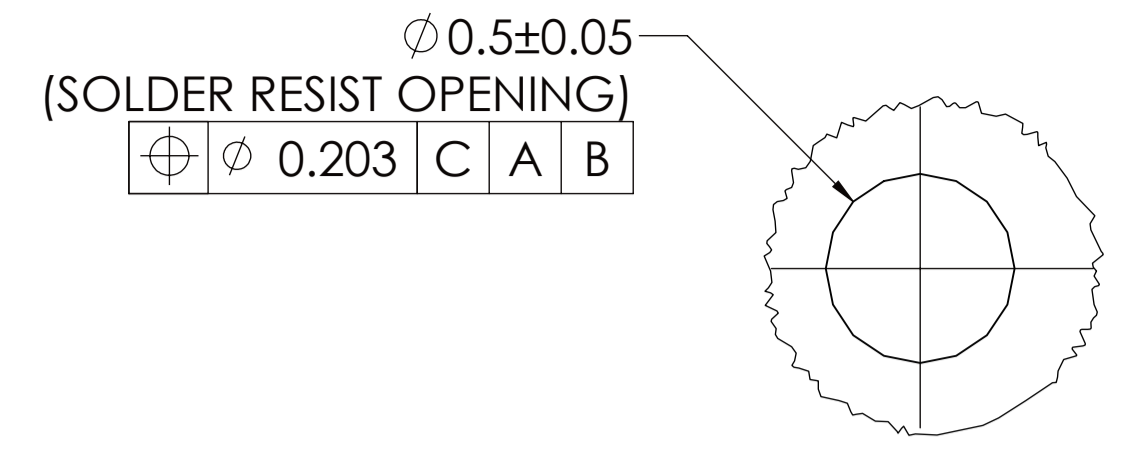

DETAIL E
LSC FIDUCIAL
SCALE 50 : 1
2X

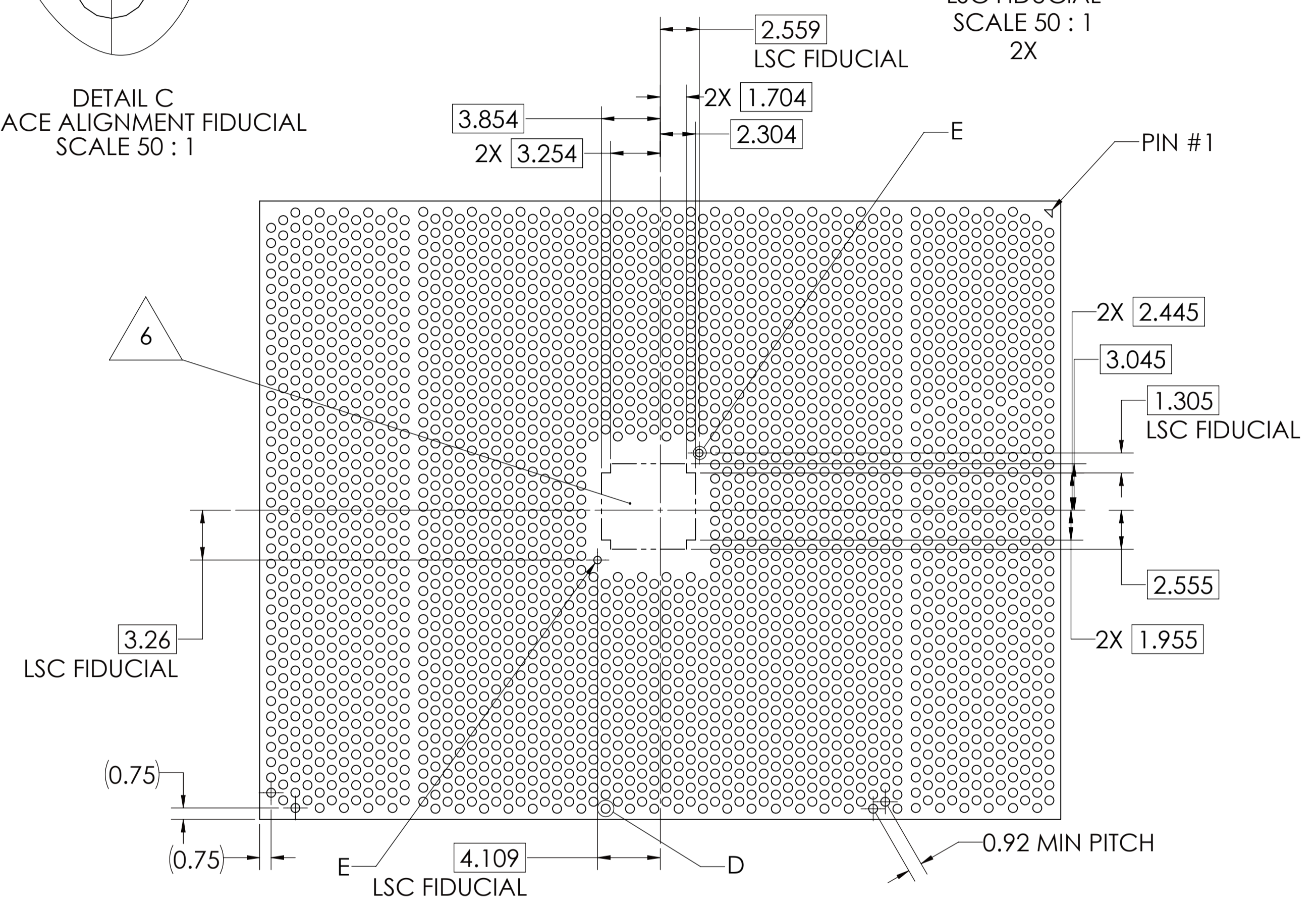

BOTTOM VIEW

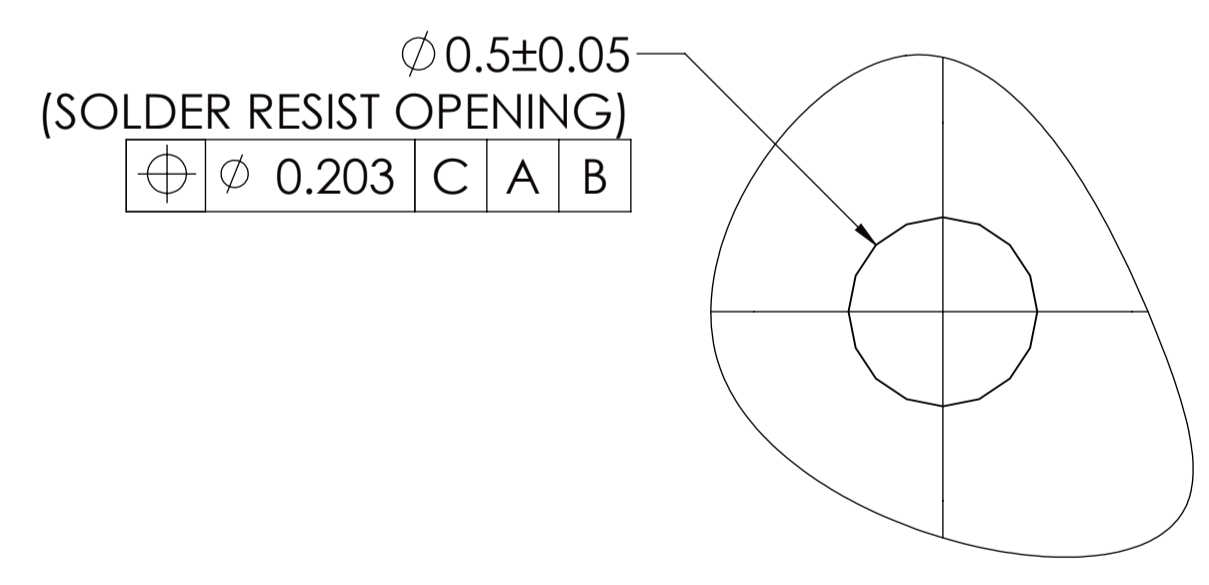

DETAIL B
SURFACE ALIGNMENT FIDUCIAL
2X
SCALE 50 : 1

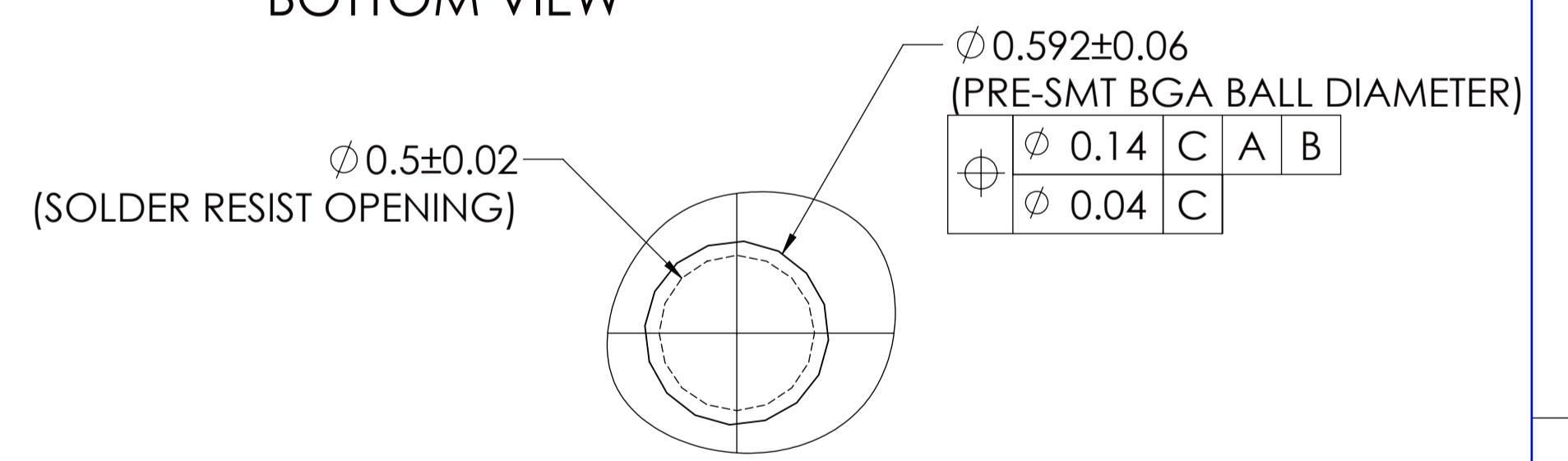

DETAIL D
SCALE 50 : 1
2581X

UNLESS OTHERWISE SPECIFIED: DIMENSIONS ARE IN MILLIMETERS. INTERPRET DIMENSIONS AND TOLERANCES PER ASME Y14.5-2009.	DESIGNED BY	DATE	DEPARTMENT	 2200 MISSION COLLEGE BLVD. P.O. BOX 58119 SANTA CLARA, CA 95052-8119
	DRAWN BY	DATE	TITLE	
	CHECKED BY	DATE	PACKAGE MECHANICAL DRAWING 52.5mm X 40.5mm, 7-2-7 16-LAYER STACKUP, 2581 BGA	
	APPROVED BY	DATE		
MATERIAL:	THIRD ANGLE PROJECTION			SIZE
SEE NOTES				A1
	SCALE: 4:1			DRAWING NUMBER
	DO NOT SCALE DRAWING			M15694
	SHEET 1 OF 2			REV
				02

8

7

6

5

4

3

1

H

H

G

G

F

F

E

E

D

D

C

C

B

B

A

A

ZONE	REV	DESCRIPTION	DATE	APPR.
-	1	ENGINEERING RELEASE	7/9/2020	NB
SH1 H8	2	REMOVED PRELIMINARY FLAGNOTES AND CONFIDENTIALITY TEMPLATE	5/8/2023	CJ

8

7

6

5

4

3

2

1