

NOTES:
 1. ALL TOLERANCES ARE RSS (4 SIGMA).
 2. ALL Z STACK UP HEIGHT ESTIMATES ARE BASED ON PRE SMT BALL HEIGHT.
 3. MARK KEEP IN ZONE, NO COMPONENTS ALLOWED.
 4. NOMINAL PACKAGE MASS ESTIMATE = 33.072 GRAMS. ACTUAL MASS MAY VARY DUE TO MANUFACTURING PROCESS.
 5. ALL Z-HEIGHT RELATED DIMENSIONS ARE BASED ON LIMITED SAMPLING DATA.
 6. LAND SIDE COMPONENT KEEP IN ZONE.

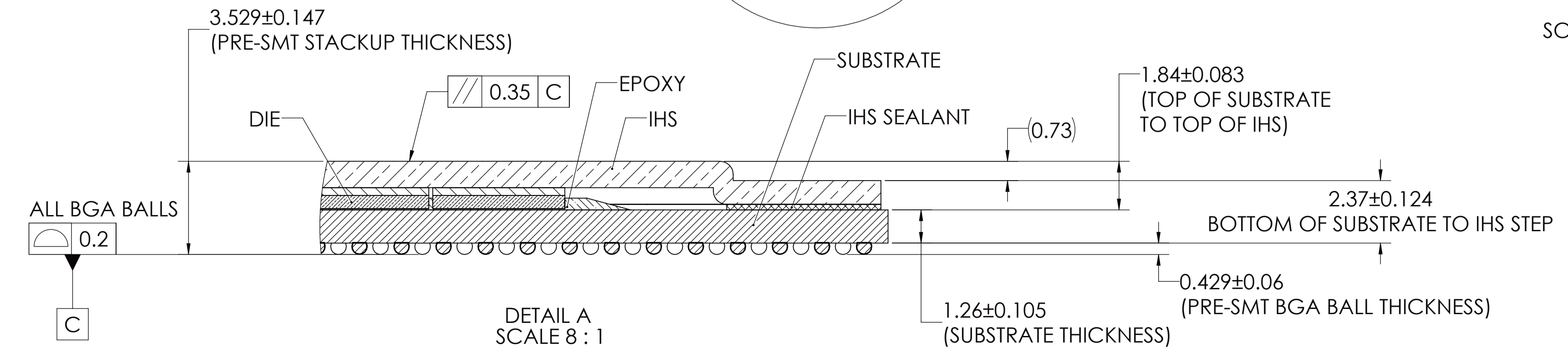
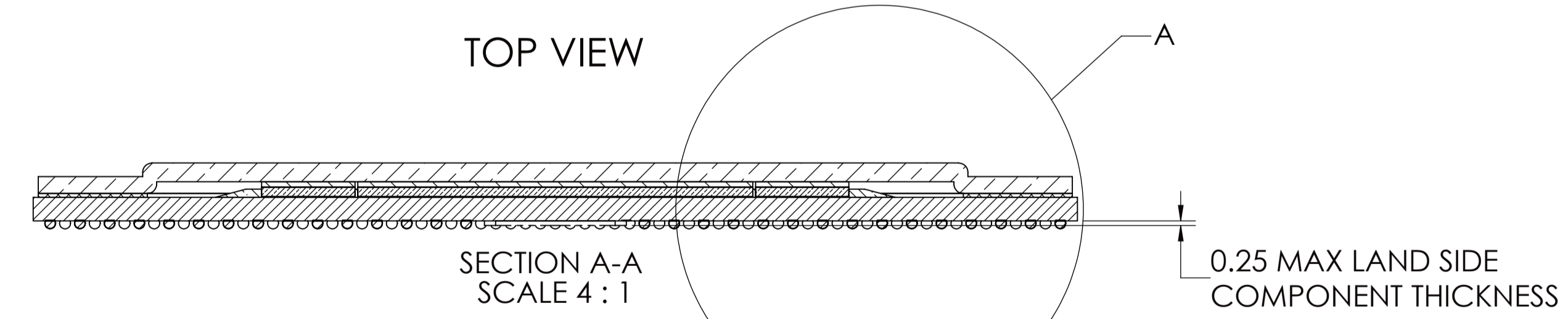
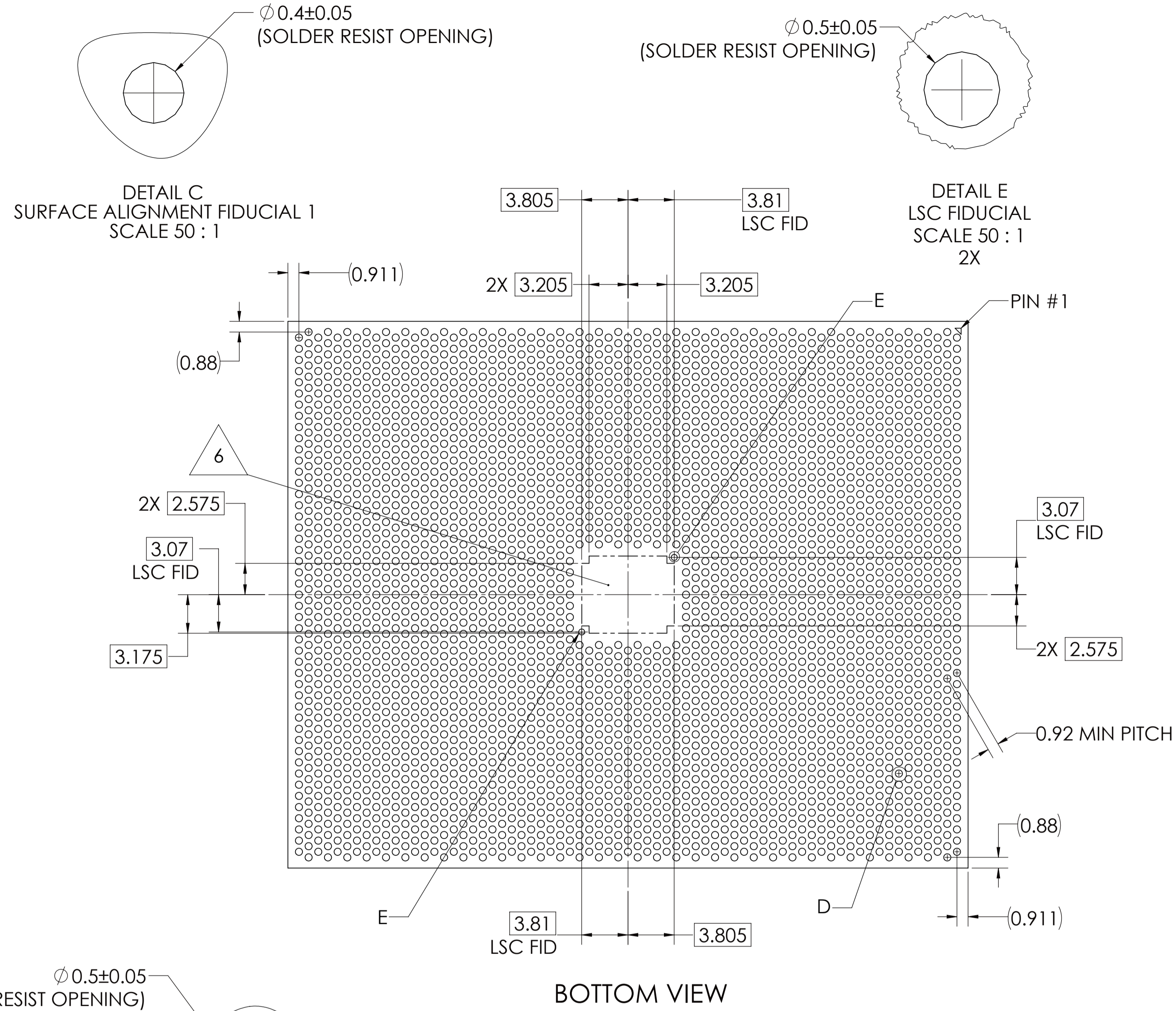
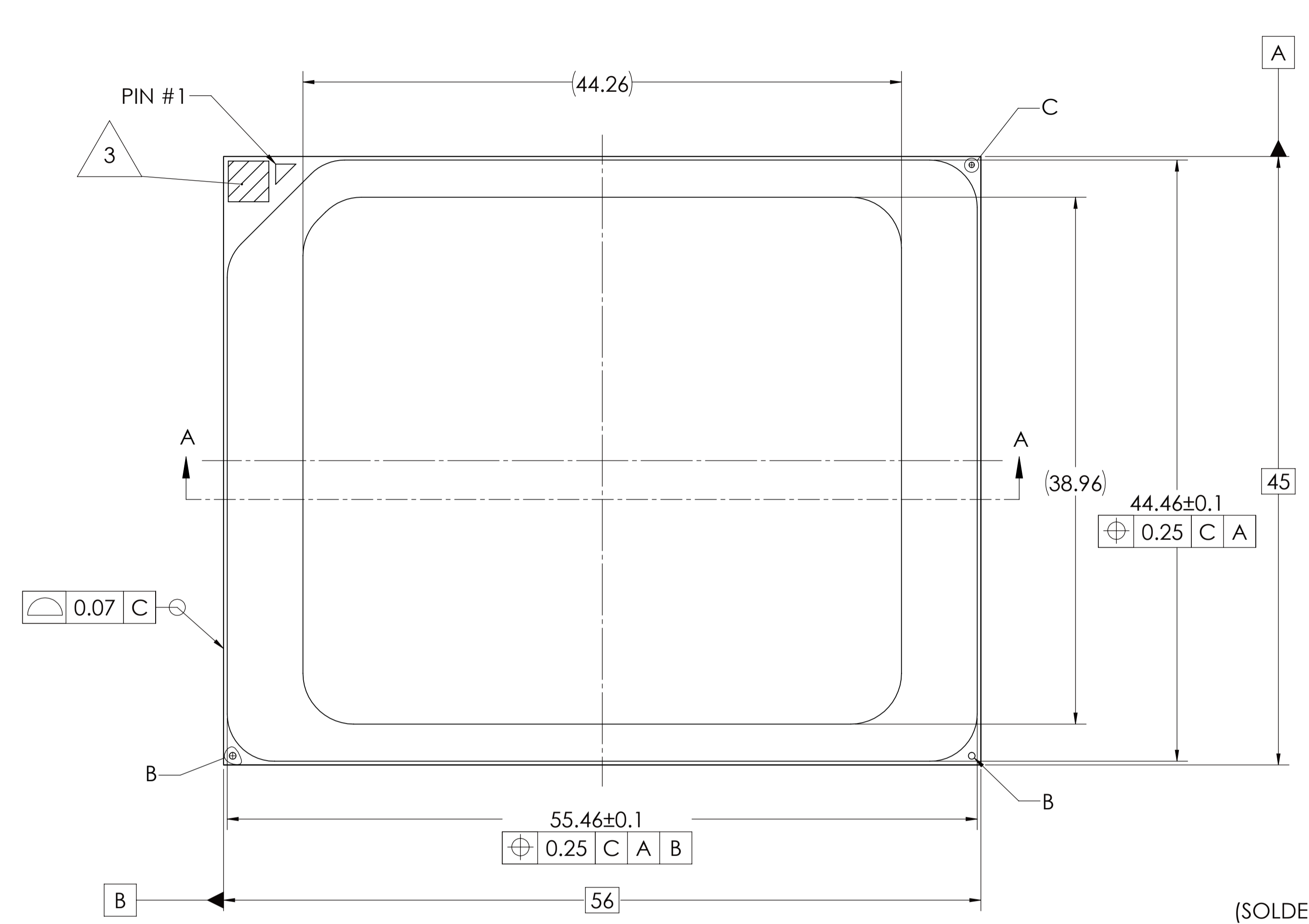

UNLESS OTHERWISE SPECIFIED: DIMENSIONS ARE IN MILLIMETERS. INTERPRET DIMENSIONS AND TOLERANCES PER ASME Y14.5-2009.	DESIGNED BY	DATE	DEPARTMENT	2200 MISSION COLLEGE BLVD. P.O. BOX 58119 SANTA CLARA, CA 95052-8119
	DRAWN BY	DATE	TITLE	
	CHECKED BY	DATE	PACKAGE MECHANICAL DRAWING	
	APPROVED BY	DATE	56mm X 45mm, 5-2-5 12 LAYER STACKUP, 3184 BGA	
MATERIAL:	THIRD ANGLE PROJECTION		SIZE	REV
SEE NOTES			A1	03
			DRAWING NUMBER	SHEET 1 OF 2
			M72657	
			SCALE: 4:1	DO NOT SCALE DRAWING

8

7

6

5

4

3

1

ZONE	REV	DESCRIPTION	DATE	APPR.
-	1	PRELIMINARY RELEASE	1/24/2022	CJ
SH1 A8	2	UPDATED COPLANARITY TO 0.2mm AND REMOVED HIGH TEMPERATURE NOTE	8/3/2022	SM
SH1 H8	3	REMOVED PRELIMINARY VALUES FLAGNOTE.	2/2/2023	CJ

8

7

6

5

4

3

2

1

H
G
F
E
D
C
B
A

H
G
F
E
D
C
B
A