



# Intel<sup>®</sup> Ethernet Network Adapter E810-XXVDA4T

User Guide

---

NEX Cloud Networking Group (NCNG)

*July 2024*

Revision 1.6  
646265-006

## Revision History

Revision	Date	Comments
1.6	July 4, 2024	<p>Updates include the following:</p> <ul style="list-style-type: none"> <li>• Updated <a href="#">Section 1.0</a>, "Introduction".</li> <li>• Updated <a href="#">Table 1</a>, "Reference Documents".</li> <li>• Updated <a href="#">Section 2.1</a>, "E810-XXVDA4T Features".</li> <li>• Updated <a href="#">Table 2</a>, "E810-XXVDA4T Product Information".</li> <li>• Updated <a href="#">Section 2.2</a>, "Architecture".</li> <li>• Updated <a href="#">Section 3.1</a>, "Software Support/Packages".</li> <li>• Updated <a href="#">Section 3.2</a>, "Building a linuxptp Project".</li> <li>• Updated <a href="#">Section 3.4</a>, "Building a sync4I Tool".</li> <li>• Updated <a href="#">Section 4.4</a>, "Channel 1 Configurations".</li> <li>• Updated <a href="#">Section 4.5</a>, "Channel 2 Configurations".</li> <li>• Updated <a href="#">Section 4.6</a>, "Recovered Clocks (G.8261 SyncE Support)".</li> <li>• Updated <a href="#">Section 4.7</a>, "External Timestamp Signals".</li> <li>• Updated <a href="#">Section 4.8</a>, "Periodic Outputs from DPLL (SMA and U.FL Pins)".</li> <li>• Updated <a href="#">Section 4.9</a>, "Reading Status of the DPLL".</li> <li>• Updated <a href="#">Section 4.10</a>, "DPLL Monitoring".</li> <li>• Updated <a href="#">Section 4.11.1</a>, "pin_cfg User Readable Format".</li> <li>• Updated <a href="#">Section 4.12</a>, "1PPS Signals from E810 Device to DPLL".</li> <li>• Updated <a href="#">Section 4.14</a>, "GNSS Module Interface".</li> <li>• Updated <a href="#">Section 7</a>, "Supported GNSS and Signals on ZED-F9T=00B".</li> <li>• Updated <a href="#">Section 4.15.5</a>, "Perform Survey-In for New Location Setup".</li> <li>• Updated <a href="#">Section 4.15.7</a>, "Saving Survey-In Position to FLASH".</li> <li>• Updated <a href="#">Section 4.15.8</a>, "Simulate Antenna Removal".</li> <li>• Updated <a href="#">Section 4.15.9</a>, "Check GNSS Overall Configuration Performance".</li> <li>• Updated <a href="#">Figure 5</a>, "External Connections: PTP GrandMaster with Optional GNSS Module" on page 45.</li> <li>• Updated <a href="#">Figure 6</a>, "External Connections: Single E810-XXVDA4T Adapter Configuration with GNSS" on page 45.</li> <li>• Updated <a href="#">Section 5.2.2</a>, "Software Configuration".</li> <li>• Updated <a href="#">Figure 8</a>, "External Connections: PTP GrandMaster with External GNSS Clock" on page 47.</li> <li>• Updated <a href="#">Section 5.3.2</a>, "Software Configuration".</li> <li>• Updated <a href="#">Figure 9</a>, "External Connections: Boundary Clock Configuration" on page 49.</li> <li>• Updated <a href="#">Section 5.4.3</a>, "Software Configuration".</li> <li>• Updated <a href="#">Figure 10</a>, "External Connections: Port Configured as TimeReceiver" on page 51.</li> <li>• Updated <a href="#">Figure 11</a>, "External Connections: SyncE Setup" on page 53.</li> <li>• Updated <a href="#">Section 5.6.2</a>, "Physical Clock Recovery".</li> <li>• Updated <a href="#">Section 5.6.3</a>, "ITU G.8264 ESMC Messaging Using sync4I".</li> <li>• Updated <a href="#">Figure 12</a>, "External Connections: Two E810-XXVDA4T Adapters without GNSS" on page 54.</li> <li>• Updated <a href="#">Figure 16</a>, "External Connections: Two E810-XXVDA4T Adapter Configuration (no GNSS)" on page 57.</li> <li>• Updated <a href="#">Figure 20</a>, "External Connections: Two E810-XXVDA4T Adapter Configuration (with GNSS)" on page 60.</li> <li>• Updated <a href="#">Figure 25</a>, "O-RAN Configuration 1 Connections" on page 63.</li> <li>• Updated <a href="#">Section 5.7.2</a>, "Software Configuration".</li> <li>• Updated <a href="#">Section 5.9</a>, "Example ptp4I Configuration File for BC".</li> <li>• Updated <a href="#">Section 5.10</a>, "Example sync4I Configuration File for BC".</li> <li>• Updated <a href="#">Figure 26</a>, "Test Setup" on page 70.</li> <li>• Updated <a href="#">Section 6.2.1</a>, "TimeTransmitter Adapter".</li> <li>• Updated <a href="#">Section 6.2.2</a>, "TimeReceiver Adapter".</li> <li>• Updated <a href="#">Figure 27</a>, "Test Results" on page 72.</li> <li>• Updated <a href="#">Appendix A</a>, "Debug Notes".</li> </ul>

Revision	Date	Comments
1.5	October 18, 2023	<p>Updates include the following:</p> <ul style="list-style-type: none"> <li>• Updated <a href="#">Section 2.1, "E810-XXVDA4T Features"</a>.</li> <li>• Updated operating temperature in <a href="#">Table 2.1, "E810-XXVDA4T Features"</a>.</li> <li>• Updated <a href="#">Section 3.1, "Software Support/Packages"</a>.</li> <li>• Updated <a href="#">Section 3.2, "Building a linuxptp Project"</a>.</li> <li>• Updated <a href="#">Section 4.4, "Channel 1 Configurations"</a>.</li> <li>• Updated <a href="#">Section 4.5, "Channel 2 Configurations"</a>.</li> <li>• Updated <a href="#">Section 4.6, "Recovered Clocks (G.8261 SyncE Support)"</a>.</li> <li>• Updated <a href="#">Section 4.7, "External Timestamp Signals"</a>.</li> <li>• Updated <a href="#">Section 4.9, "Reading Status of the DPLL"</a>.</li> <li>• Updated <a href="#">Section 4.10, "DPLL Monitoring"</a>.</li> <li>• Updated <a href="#">Section 4.11, "Advanced DPLL Configuration"</a>.</li> <li>• Updated <a href="#">Section 4.12, "1PPS Signals from E810 Device to DPLL"</a>.</li> <li>• Updated <a href="#">Section 4.13, "1PPS Signals from the DPLL to E810 Device"</a>.</li> <li>• Updated <a href="#">Section 4.14, "GNSS Module Interface"</a>.</li> <li>• Updated <a href="#">Section 4.15, "GNSS Advanced Features"</a>.</li> <li>• Updated <a href="#">Section 4.15.1, "Prerequisites and Steps to Fully Enable GNSS Features"</a>.</li> <li>• Added <a href="#">Section 4.15.2, "GNSS Receiver Configuration Layers in the E810-XXVDA4T"</a>.</li> <li>• Added <a href="#">Section 4.15.4, "Enabling and Disabling Additional Constellations"</a>.</li> <li>• Updated <a href="#">Section 4.15.5, "Perform Survey-In for New Location Setup"</a>.</li> <li>• Updated <a href="#">Section 4.15.6, "Check Survey-In Status"</a>.</li> <li>• Added <a href="#">Section 4.15.7, "Saving Survey-In Position to FLASH"</a>.</li> <li>• Added <a href="#">Section 4.15.8, "Simulate Antenna Removal"</a>.</li> <li>• Updated <a href="#">Section 4.15.9, "Check GNSS Overall Configuration Performance"</a>.</li> <li>• Updated <a href="#">Section 5.2.2, "Software Configuration"</a>.</li> <li>• Updated <a href="#">Section 5.3.2, "Software Configuration"</a>.</li> <li>• Updated <a href="#">Section 5.6.6, "Two E810-XXVDA4T Adapters with GNSS Connection Setup"</a>.</li> <li>• Updated <a href="#">Section 5.8, "Example ts2phc Configuration File"</a>.</li> <li>• Updated <a href="#">Section 5.9, "Example ptp4l Configuration File for BC"</a>.</li> <li>• Updated <a href="#">Section 6.2.1, "TimeTransmitter Adapter"</a>.</li> <li>• Updated <a href="#">Appendix A, "Debug Notes"</a>.</li> </ul>
1.4	March 7, 2023	<p>Updates include the following:</p> <ul style="list-style-type: none"> <li>• Updated <a href="#">Section 3.1, "Software Support/Packages"</a>.</li> <li>• Updated <a href="#">Section 4.2, "DPLL Priority"</a>.</li> <li>• Updated <a href="#">Section 4.6, "Recovered Clocks (G.8261 SyncE Support)"</a>.</li> <li>• Updated <a href="#">Section 4.7, "External Timestamp Signals"</a>.</li> <li>• Updated <a href="#">Section 4.9, "Reading Status of the DPLL"</a>.</li> <li>• Updated <a href="#">Section 4.10, "DPLL Monitoring"</a>.</li> <li>• Updated <a href="#">Section 4.11.1, "pin_cfg User Readable Format"</a>.</li> <li>• Updated <a href="#">Section 4.12, "1PPS Signals from E810 Device to DPLL"</a>.</li> <li>• Updated <a href="#">Section 4.13, "1PPS Signals from the DPLL to E810 Device"</a>.</li> <li>• Updated <a href="#">Section 4.14, "GNSS Module Interface"</a>.</li> <li>• Updated <a href="#">Section 4.15, "GNSS Advanced Features"</a>.</li> <li>• Updated <a href="#">Section 4.15.1, "Prerequisites and Steps to Fully Enable GNSS Features"</a>.</li> <li>• Updated <a href="#">Section 4.15.3, "Perform Antenna Status Check New Location Setup"</a>.</li> <li>• Updated <a href="#">Section 4.15.5, "Perform Survey-In for New Location Setup"</a>.</li> <li>• Updated <a href="#">Section 4.15.6, "Check Survey-In Status"</a>.</li> <li>• Updated <a href="#">Section 4.15.9, "Check GNSS Overall Configuration Performance"</a>.</li> <li>• Updated <a href="#">Section 5.2.2, "Software Configuration"</a>.</li> <li>• Updated <a href="#">Section 5.4.3, "Software Configuration"</a>.</li> <li>• Updated <a href="#">Section 5.5.2, "Software Configuration"</a>.</li> <li>• Updated <a href="#">Section 5.6.5, "Two E810-XXVDA4T Adapter Configuration without GNSS and with 1PPS"</a>.</li> <li>• Updated <a href="#">Section 5.8, "Example ts2phc Configuration File"</a>.</li> <li>• Updated <a href="#">Section 5.9, "Example ptp4l Configuration File for BC"</a>.</li> <li>• Updated <a href="#">Section 6.2.2, "TimeReceiver Adapter"</a>.</li> <li>• Updated <a href="#">Appendix A, "Debug Notes"</a>.</li> </ul>

Revision	Date	Comments
1.3	December 15, 2022	<p>Updates include the following:</p> <ul style="list-style-type: none"> <li>• Updated GNSS interface naming to /dev/ttyGNSS_BBDD.</li> <li>• Added <a href="#">Section 2.3, "Synchronization Signaling"</a>.</li> <li>• Added <a href="#">Section 2.4, "Optional GNSS Module"</a>.</li> <li>• Added <a href="#">Section 3.4, "Building a synce4l Tool"</a>.</li> <li>• Updated <a href="#">Section 4.1, "Introduction"</a>.</li> <li>• Added notes to <a href="#">Section 4.7, "External Timestamp Signals"</a>.</li> <li>• Updated <a href="#">Section 4.9, "Reading Status of the DPLL"</a>.</li> <li>• Updated <a href="#">Section 4.11.1, "pin_cfg User Readable Format"</a>.</li> <li>• Updated <a href="#">Section 4.11.2, "dpll_&lt;X&gt;_ref_pin/dpll_&lt;X&gt;_state Machine Readable Interface (X = 0 /1)"</a>.</li> <li>• Updated <a href="#">Section 4.14, "GNSS Module Interface"</a>.</li> <li>• Added <a href="#">Section 4.15, "GNSS Advanced Features"</a>.</li> <li>• Updated <a href="#">Section 5.2.1, "External Connections"</a>.</li> <li>• Updated <a href="#">Section 5.2.2, "Software Configuration"</a>.</li> <li>• Updated <a href="#">Section 5.3.2, "Software Configuration"</a>.</li> <li>• Updated <a href="#">Section 5.4.3, "Software Configuration"</a>.</li> <li>• Updated <a href="#">Section 5.6, "SyncE Setup"</a>.</li> <li>• Added <a href="#">Section 5.6.3, "ITU G.8264 ESMC Messaging Using synce4l"</a>.</li> <li>• Added <a href="#">Section 5.6.4, "Two E810-XXVDA4T Adapter Configuration without GNSS"</a>.</li> <li>• Added <a href="#">Section 5.6.5, "Two E810-XXVDA4T Adapter Configuration without GNSS and with 1PPS"</a>.</li> <li>• Added <a href="#">Section 5.6.6, "Two E810-XXVDA4T Adapters with GNSS Connection Setup"</a>.</li> <li>• Added <a href="#">Section 5.10, "Example synce4l Configuration File for BC"</a>.</li> <li>• Updated <a href="#">Section 6.2.1, "TimeTransmitter Adapter"</a>.</li> <li>• Updated <a href="#">Section 6.2.2, "TimeReceiver Adapter"</a>.</li> <li>• Updated <a href="#">Appendix A, "Debug Notes"</a>.</li> </ul>
1.2	June 15, 2022	<p>Updates include the following:</p> <ul style="list-style-type: none"> <li>• Updated <a href="#">Section 3.1, "Software Support/Packages"</a>.</li> <li>• Updated <a href="#">Section 5.9, "Example ptp4l Configuration File for BC"</a>.</li> </ul>
1.1	March 25, 2022	<p>Updates include the following:</p> <ul style="list-style-type: none"> <li>• Updated <a href="#">Section 3.1, "Software Support/Packages"</a>.</li> <li>• Updated <a href="#">Section 4.9, "Reading Status of the DPLL"</a>.</li> <li>• Added <a href="#">Section 4.11.1, "pin_cfg User Readable Format"</a>.</li> <li>• Added <a href="#">Section 4.11.2, "dpll_&lt;X&gt;_ref_pin/dpll_&lt;X&gt;_state Machine Readable Interface (X = 0 /1)"</a>.</li> <li>• Updated <a href="#">Section 4.14, "GNSS Module Interface"</a>.</li> <li>• Updated <a href="#">Section 5.2.2, "Software Configuration"</a>.</li> <li>• Updated <a href="#">Section 5.3.2, "Software Configuration"</a>.</li> <li>• Updated <a href="#">Appendix A, "Debug Notes"</a>.</li> </ul>
1.0	February 18, 2022	Initial public release.

**NOTE:**        *This page intentionally left blank.*



## Contents

---

<b>1.0</b>	<b>Introduction</b>	<b>9</b>
1.1	Reference Documents	9
<b>2.0</b>	<b>E810-XXVDA4T Ethernet Network Adapter</b>	<b>11</b>
2.1	E810-XXVDA4T Features	11
2.2	Architecture	13
2.3	Synchronization Signaling	15
2.4	Optional GNSS Module	15
<b>3.0</b>	<b>Software, Firmware, and Drivers</b>	<b>16</b>
3.1	Software Support/Packages	16
3.2	Building a linuxptp Project	18
3.3	Related linuxptp Information	18
3.4	Building a sync4l Tool	19
<b>4.0</b>	<b>Configuring the E810-XXVDA4T Using the Linux Kernel Interface</b>	<b>20</b>
4.1	Introduction	20
4.2	DPLL Priority	21
4.3	External Connectors	22
4.4	Channel 1 Configurations	23
4.5	Channel 2 Configurations	25
4.6	Recovered Clocks (G.8261 SyncE Support)	26
4.7	External Timestamp Signals	27
4.8	Periodic Outputs from DPLL (SMA and U.FL Pins)	27
4.9	Reading Status of the DPLL	28
4.10	DPLL Monitoring	29
4.11	Advanced DPLL Configuration	30
4.11.1	pin_cfg User Readable Format	30
4.11.2	dpll_<X>_ref_pin/dpll_<X>_state Machine Readable Interface (X = 0 /1)	32
4.12	1PPS Signals from E810 Device to DPLL	33
4.13	1PPS Signals from the DPLL to E810 Device	33
4.14	GNSS Module Interface	34
4.15	GNSS Advanced Features	35
4.15.1	Prerequisites and Steps to Fully Enable GNSS Features	35
4.15.2	GNSS Receiver Configuration Layers in the E810-XXVDA4T	38
4.15.3	Perform Antenna Status Check New Location Setup	39
4.15.4	Enabling and Disabling Additional Constellations	40
4.15.5	Perform Survey-In for New Location Setup	40
4.15.6	Check Survey-In Status	41
4.15.7	Saving Survey-In Position to FLASH	41
4.15.8	Simulate Antenna Removal	41
4.15.9	Check GNSS Overall Configuration Performance	42
<b>5.0</b>	<b>Configuration Setup</b>	<b>43</b>
5.1	Disable All SMA and U.FL Connections	44
5.2	PTP GrandMaster (GM) with Optional GNSS Module	44
5.2.1	External Connections	45
5.2.2	Software Configuration	46
5.3	PTP GrandMaster (GM) with External GNSS Clock	47
5.3.1	External Connections	47
5.3.2	Software Configuration	47
5.4	Boundary Clock Configuration	49
5.4.1	External Connections	49
5.4.2	Boundary Clock Notes	49

5.4.3	Software Configuration .....	49
5.5	Port Configured as TimeReceiver .....	51
5.5.1	External Connections .....	51
5.5.2	Software Configuration .....	51
5.6	SyncE Setup .....	53
5.6.1	External Connections .....	53
5.6.2	Physical Clock Recovery .....	53
5.6.3	ITU G.8264 ESMC Messaging Using sync4l .....	54
5.6.4	Two E810-XXVDA4T Adapter Configuration without GNSS.....	54
5.6.5	Two E810-XXVDA4T Adapter Configuration without GNSS and with 1PPS .....	57
5.6.6	Two E810-XXVDA4T Adapters with GNSS Connection Setup .....	60
5.7	O-RAN Configuration 1 .....	63
5.7.1	External Connections .....	63
5.7.2	Software Configuration .....	63
5.8	Example ts2phc Configuration File .....	64
5.9	Example ptp4l Configuration File for BC .....	64
5.10	Example sync4l Configuration File for BC .....	66
<b>6.0</b>	<b>Initial Test Setup .....</b>	<b>70</b>
6.1	Test Diagram .....	70
6.2	Software Configuration .....	70
6.2.1	TimeTransmitter Adapter .....	70
6.2.2	TimeReceiver Adapter .....	71
6.2.3	Test Results .....	72
<b>Appendix A</b>	<b>Debug Notes .....</b>	<b>73</b>
<b>Appendix B</b>	<b>Glossary and Acronyms .....</b>	<b>79</b>



## 1.0 Introduction

Although IEEE 1588 Precision Time Protocol (PTP) support has been part of Intel's controller product line for generations. Intel only recently began developing PTP-optimized Ethernet Network Adapter products. The adoption of PTP in Ethernet connections is growing rapidly. Although the TimeTransmitter use case being considered is the build-out of 5G infrastructure, other applications that exist in datacenters, point of presence, financial, industrial, and energy sectors. These application areas can benefit from timing optimized, standard form factor, Ethernet adapters.

The Intel® Ethernet Network Adapter E810-XXVDA4T (E810-XXVDA4T), is based on the Intel® Ethernet Controller E810 (E810).

This document is structured as follows:

- Section 2.0, "E810-XXVDA4T Ethernet Network Adapter"
- Section 3.0, "Software, Firmware, and Drivers"
- Section 4.0, "Configuring the E810-XXVDA4T Using the Linux Kernel Interface"
- Section 5.0, "Configuration Setup"
- Section 6.0, "Initial Test Setup"
- Appendix A, "Debug Notes"
- Appendix B, "Glossary and Acronyms"

**Note:** In accordance with changes made in the IEEE 1588 Specification and where possible, the words Master and Slave have been replaced with TimeTransmitter (TT) and TimeReceiver (TR), previous version of the document used Leader and Follower, respectively.

### 1.1 Reference Documents

Table 1 lists documents that can be found on the Intel Resource and Design Center (RDC) at:

<https://www.intel.com/content/www/us/en/design/resource-design-center.html>

**Table 1. Reference Documents**

Document Title	Document ID
Intel® Ethernet Controller E810 Datasheet	613875
Intel® Ethernet Controller E810 Specification Update	616943
Intel® Ethernet Controller E810 Feature Support Matrix	630155
Intel® Ethernet Network Adapter E810-XXVDA4T Overview Video	730682
Intel® Ethernet Network Adapter E810-XXVDA4T Product Brief	641626
Intel® Ethernet Network Adapter E810-XXVDA4T - 68808 - MDDS	727036
Intel® Ethernet Network Adapter E810-XXVDA4T Product Brief	641626

Other documents that might be of interest include the following:

- IEEE 1588-2008 (v2.0)
- IEEE 1588-2019 (v2.1)
- IEEE 802.3AS
- ITU-T G.8271



- ITU-T G.8273
- ITU-T G.8273.2
- ITU-T G.8275.1
- ITU-T G.8275.2

**Note:** Linux PTP project information can be found at:  
<http://linuxptp.sourceforge.net/>

## 2.0 E810-XXVDA4T Ethernet Network Adapter

### 2.1 E810-XXVDA4T Features

Following are the features of the Intel® Ethernet Network Adapter E810-XXVDA4T:

- Based on Intel® Ethernet Controller E810 device using SFP28 form factor connections, as well as inheriting most of the features from the Intel® Ethernet Network Adapter E810-XXVDA4 (E810-XXVDA4).
- Software capability to configure the SMA signals via the standard Linux driver.
- Driver support for Linux PTP stack (**ptp4l**) to send synchronization messages and synchronize the host system clock to the adapter's PHC. This is present in all Intel network adapters.
- **ts2phc** utility for the Linux PTP stack optimized for synchronizing the PHC to a 1PPS input, rather than PTP messages.
- When combined with an external GNSS 1PPS input, the features of the adapter and Linux PTP stack provide the complete solution for a low cost PTP GrandMaster, while maintaining the ability to provide the host system's LAN connectivity.
- Exposed PTP timing signals on a front panel using SMA connectors. This enables timing signals to easily be connected by the end user after the adapter is installed in a system. Timing signals on the SMAs can be configured as inputs or outputs, typically configured for one pulse per second (1PPS) operation, but they will support a 10 MHz signal (with or without the embedded 1PPS eSync). The rising edge of the 1PPS signal is used to mark the start of a new second, Top of Second (ToS). A 1PPS input signal is typically sourced from a GNSS module, or might be connected to the 1PPS output of another adapter. Circuitry is provided on board for isolation, buffering, and level-shifting to adapt the controller's CMOS signals for out-of-system use. Refer to [Section 2.3](#) for 1PPS and 10 MHz signaling electrical requirements.
- In addition to the dual SMA connectors, the E810-XXVDA4T also includes two U.FL connectors for 1PPS and/or 10 MHz; one is output only and the other is input only. This enables hardware-level traceability for connections to motherboards that do not have room for external SMA connectors.
- High accuracy reference clock. Intel adapters typically use on-board reference clocks with accuracy in the range of  $\pm 50$  parts per million (ppm) as required to meet the Ethernet PHY requirements. Increased reference clock accuracy to  $\pm 2$  parts per billion (ppb) can be achieved using an Oven-Controlled Crystal Oscillator (OCXO). This tighter accuracy enables the PTP Hardware Clock (PHC) inside the E810 to drift more slowly in the event the 1PPS source, or software adjustment via 1588 sync protocol, is lost. The ability to maintain time after the reference source is lost is known as holdover. This is estimated to extend holdover time to  $\sim 4$  hours for  $\pm 1.5$   $\mu$ s.
- Add support for Synchronous Ethernet (SyncE) clock recovery (ITU G.8262).
- Add a high-quality DPLL to support multiple input clock functions and multiple output frequencies. The DPLL IC has separate integrated DPLL instances DPLL0 is used for generating high stability clock signal and DPLL1 used for driving the output signals.
- The timing information from the DPLL (that can arrive from the GNSS module, SMA connectors, E810 SDPs, or from the recovered SyncE signals) are routed to the E810 and can be used to synchronize the PHC (PTP hardware clocks). All E810 ports share only one physical PHC, and this is particularly useful in creating a Boundary Clock (BC) functionality like what is defined in ITU-T G.8273.2 (but without SyncE).
- Add mounting and connection provision for an optional GNSS module on board. When installed, the GNSS module provides the 1PPS signal without the need for an external GNSS appliance. An I<sup>2</sup>C interface provides a way to access the serial port data on the GNSS, including configuration options.

Table 2 provides additional information on the E810-XXVDA4T:

**Table 2. E810-XXVDA4T Product Information**

<b>Product Description</b>	1588 PTP/SyncE/GNSS 10/25GbE SFP28 PCIe adapter <sup>1</sup>
<b>Product Codes</b>	E810-XXVDA4TG1 (no GNSS) E810-XXV-DA4TGG1 (with GNSS)
<b>Host Interface</b>	PCIe 3.0x16 or PCIe 4.0x8/x16 (x16 connector)
<b>Form Factor</b>	Full-height, half-length PCIe card
<b>Front Panel Connectors</b>	4x SFP28, 2x SMA (1PPS/10 MHz) <sup>2</sup> , 1x SMB (GNSS antenna) <sup>3</sup>
<b>Internal Connectors</b>	1x U.FL input + 1x U.FL output (1PPS/10 MHz); GNSS mezzanine
<b>Optional GNSS SKU</b>	Supports GPS, Galileo, GLONASS, BeiDou, QZSS
<b>Synchronous Ethernet</b>	ITU-T G.8261, G.8262, G.8262.1, and G.8264 (ESMC) support
<b>Oscillator</b>	1 ppb vs. temperature, 4 hours holdover ( $\pm 1.5 \mu\text{s}$ under $\pm 5 \text{ }^\circ\text{C } \Delta\text{T}$ )
<b>Power</b>	23 W typical, 34 W max power consumption (with Class 3 optics at 25G maximum traffic)
<b>Operating Temperature</b>	0-65 °C with required airflow (passive heat sink)
<b>EMI</b>	FCC Class A
<b>Manageability</b>	NC-SI over MCTP (over PCIe/SMBus); EFI based iSCSI boot; EFI/legacy PXE boot support

1. 10M/100M speeds are not supported.
2. Refer to [Section 2.3](#) for 1PPS and 10 MHz signaling requirements.
3. Refer to [Table 3](#) for GNSS antenna characteristics.

## 2.2 Architecture

The block diagram for the E810-XXVDA4T is shown in Figure 1. The E810-XXVDA4T provides two coaxial input/output SMA connectors, two U.FL connectors, and an optional GNSS input connector, as shown in Figure 2.

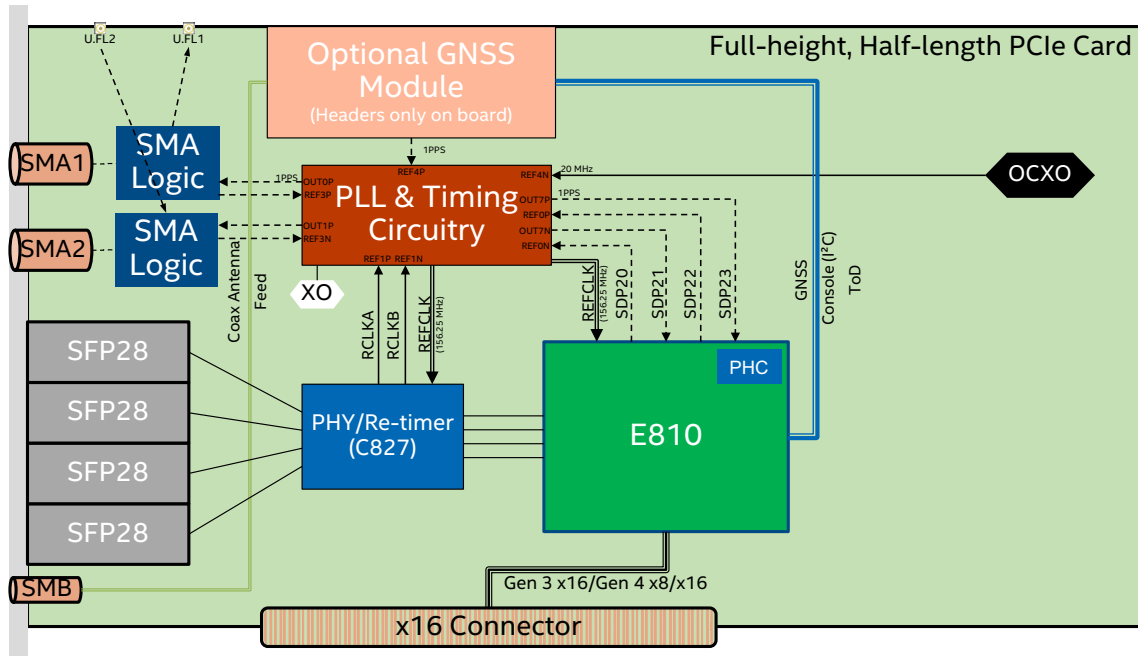

Figure 1. E810-XXVDA4T Block Diagram

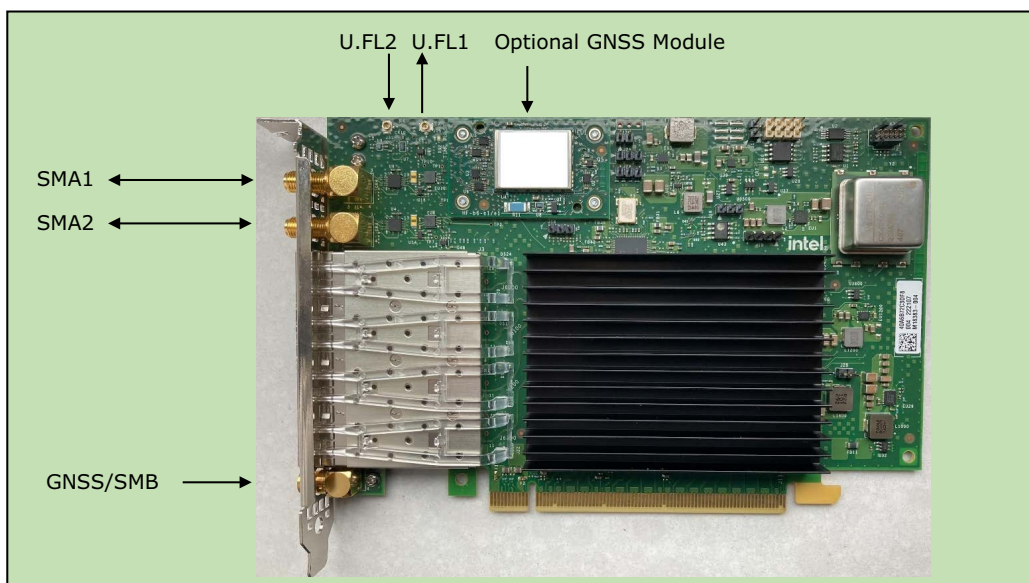

Figure 2. E810-XXVDA4T Connector Locations

The optional GNSS module has a connection to an external antenna via an SMB female connector at the bottom of the faceplate. A cable with an SMB male connector and the characteristics listed in [Table 3](#) are required to use the GNSS.

**Table 3. E810-XXVDA4T GNSS Antenna Characteristics**

Characteristic	Min	Typical	Max
Characteristic impedance	-	50 Ω	-
DC operating voltage	2.9 V	3.3 V	3.6 V
Current consumption	-	-	30 mA
EMI immunity out-of-band	-	30 V/m	-
Out-of-band rejection	-	40 dB	-
Gain of active LNA at WPC SMB connector	17 dB	-	50 dB
Active antenna noise figure	-	< 4 dB	-
Axial ratio	-	-	2 dB
Phase center variation	-	< 10 mm over elevation/azimuth	-
Group delay variation in-band	-	10 ns max at each GNSS system bandwidth	-

**Note:** If the antenna is mounted on the open space, please make sure that lightning protection is used.

The two SMA female connectors on the upper part of the faceplate are used for sending or receiving timing signals. Cables with SMA male connectors and the characteristics listed in [Table 4](#) are required to use the SMA ports.

**Table 4. E810-XXVDA4T Timing Propagation Cable Characteristics**

Characteristic	Min	Typical	Max
Frequency range	DC	-	>100 MHz
VSWR	-	1.25:1	1.33:1
Velocity of propagation	-	69%	-
RF shielding	-110 dB	-	-
Capacitance	-	95 pF/m	-
Impedance, cable	-	50 Ω	-
Impedance, connector (SMA or u.FL)	-	50 Ω	-
Tested cable assembly length	-	-	3 m
SMA connector torque	-	0.9 Nm	-

The U.FL cables have similar requirements as the SMA cables, except there is no torque requirement, and the tested cable length is <1 meter.

## 2.3 Synchronization Signaling

The E810-XXVDA4T has two SMA connectors at the faceplate and two on-board U.FL connectors for 1588 high precision timing connectivity. Each SMA signal can be configured to be an input or an output.

The U.FL1 connector, associated with SMA1, can be output-only. The U.FL2 connector, associated with SMA2, can be input-only. Currently, 1PPS and 10 MHz signaling on both SMA and U.FL connectors is supported; additional signaling capabilities might be supported in future releases.

The 1PPS signaling is compliant with the ITU-T G.703 specification, but the 10 MHz signaling matches the 1PPS requirements rather than the ITU-T G.703 10 MHz requirements. For devices expecting ITU-T G.703 10 MHz requirements, DC blocks (for transmitted signaling from the E810-XXVDA4T) and bias tees (for signaling received by the E810-XXVDA4T Rx) must be used.

**Table 5. E810-XXVDA4T Supported 1PPS Input Signal (50 Ω Single-Ended)**

Input	Min	Max	Units
VIH	1.65	5.5	V
VIL	-0.3	0.8	V
Rise Time		20	ns
Duty Cycle	1	51	%

**Note:** Assumes a 50 Ω termination. Parameters specified as measured at termination.

## 2.4 Optional GNSS Module

The E810-XXVDA4TGG1 SKU includes a GNSS module installed as an add-in card, which provides the E810-XXVDA4T with timing synchronization from GNSS constellations. This module outputs a 1PPS signal. Hardware support for presence detection of the antenna and current-limit protection for the E810-XXVDA4T antenna input is included on this module.

## 3.0 Software, Firmware, and Drivers

### 3.1 Software Support/Packages

1. Check the related Feature Support Matrix before installation to ensure that the correct NVM and driver versions are supported.

**E810 Technical Library:**

<https://www.intel.com/content/www/us/en/products/details/ethernet/800-controllers/e810-controllers/docs.html?s=Newest>

**Operating System Scope for E810 Timing-Enhanced Adapters:**

The following table lists the operating system support for a given release starting with Release 26.8, which represents the first production release for E810-XXVDA4T.

Operating System	Software Release Version						
	26.8	27.1/ 27.2.1	27.5/ 27.6.1	27.7	28.0/ 28.1	28.2	28.3/ 29.0
Linux RHEL 7.9	SNV	X	SNV	SNV	SNV	SNV	SNV
Linux RHEL 8.4	X	X	X	X	SNV	SNV	SNV
Linux RHEL 8.5	X	X	X	X	X	X	SNV
Linux RHEL 8.6/9	---	---	X	X	X	X	SNV
Linux RHEL 8.7/9.1	---	---	---	---	X	X	X
Linux RHEL 8.8/9.2	---	---	---	---	---	X	X
Linux RHEL 8.9/9.3	---	---	---	---	---	---	X
Linux SLES 12 SP5	X	X	SNV	SNV	SNV	SNV	SNV
Linux SLES 15 SP3	X	X	X	X	X	X	SNV
Linux SLES 15 SP4	---	---	X	X	X	X	X
Linux SLES 15 SP5	---	---	---	---	---	X	X
Linux Stable Kernel version 3.x/4.x/5.x	SNV	SNV	SNV	SNV	SNV	SNV	SNV
Linux Ubuntu 18.04 LTS	SNV	SNV	SNV	SNV	SNV	SNV	SNV
Linux Ubuntu 20.04 LTS	SNV	X	X	X	X	X	X
Linux Ubuntu 22.04 LTS	---	---	SNV	SNV	SNV	X	X
UEFI 2.1/2.3/2.4/2.6/2.7/2.8	---	X	X	X	X	X	X
UEFI 2.9	---	---	X	X	X	X	X
VMware ESX 7.0 (U2 & U3)	---	---	---	---	X	X	X
VMware ESX 8.0	---	---	---	---	X	X	X

**Legend:**

X	Supported with Intel® NVM and software driver.
---	Not supported with Intel® NVM and software driver.
SNV	Supported but Not Validated.
TBD	Available in a future release.



Refer to the *Intel® Ethernet Controller E810 Feature Support Matrix* for additional NVM and software driver details.:

<https://cdrdv2.intel.com/v1/dl/getContent/607252>

#### **NVM Update Tool:**

<https://www.intel.com/content/www/us/en/download/19624/non-volatile-memory-nvm-update-utility-for-intel-ethernet-network-adapter-e810-series.html>

Always choose the latest.

**Note:** To update the NVM, refer to the *Intel® Ethernet NVM Update Tool Quick Usage Guide for Linux*.

2. Download and install the complete driver package:

<https://www.intel.com/content/www/us/en/download/15084/intel-ethernet-adapter-complete-driver-pack.html>

Always choose the latest.

Or, download the Linux driver only:

<https://sourceforge.net/projects/e1000/files/ice%20stable/>

**Note:** For the newest features, always use the latest driver and NVM version. This document is based on driver version *ice-1.14.9.1* or newer.

**Important:** The latest *ice-1.14.9.1* driver with the 4.51 NVM version has some limitations that will be addressed in later releases.

For details, see the Release Notes:

<https://www.intel.com/content/www/us/en/download/19622/intel-ethernet-product-software-release-notes.html>

3. Install the complete driver package with the following commands:

```
# cd ice-1.x.x/src
# make -j install
```

Now reboot the system, or if not possible:

```
# rmmod ice
```

You might need to remove additional drivers that are using the *ice* driver:

```
# insmod ./intel_auxiliary.ko //Depends on the kernel version if you need it.
# modprobe gnss //Depends on the kernel version if you need it.
# insmod ./ice.ko
```

4. Update the NVM to the latest image:

```
# cd E810_NVMUpdatePackage_v4_50_Linux/Linux_x64/
# ./nvmupdate64e -u -l -c nvmupdate.cfg
```

5. Power cycle the system and check correct driver and NVM version:

```
#ethtool -i ens801f0
driver: ice
version: 1.14.9.1
firmware-version: 4.51 0x8001e488 1.3597.0
expansion-rom-version:
bus-info: 0000:84:00.0
supports-statistics: yes
supports-test: yes
supports-eeprom-access: yes
supports-register-dump: yes
supports-priv-flags: yes
```

## 3.2 Building a linuxptp Project

1. Download the latest **linuxptp** release from SourceForge (v4.21 or later):

<https://sourceforge.net/projects/linuxptp/files/latest/download>

2. or use:

```
# git clone git://git.code.sf.net/p/linuxptp/code linuxptp-4.3
```

3. Extract the downloaded archive, if required:

```
# tar xzf linuxptp-4.3.tgz
```

4. Navigate to the *linuxptp-4.3* directory and compile the source code:

```
# cd linuxptp-4.3
# make
```

5. To install the program and related man pages into */usr/local*, run `make install` with root privileges.

```
# make install
```

This enables you to run the tools from any directory.

6. For more details related to installing **linuxptp**, go to:

<http://linuxptp.sourceforge.net/>

**Note:** As the E810 family do not support the PTM technology, so phc2sys will work only in SW mode.

## 3.3 Related linuxptp Information

Following are links to related information:

- <https://github.com/richardcochran/linuxptp/blob/master/phc2sys.8>
- <https://github.com/richardcochran/linuxptp/blob/master/ptp4l.8>
- <https://github.com/richardcochran/linuxptp/blob/master/ts2phc.8>
- <https://www.mankier.com/8/ts2phc>
- <https://www.mankier.com/8/ptp4l>
- <https://www.mankier.com/8/phc2sys>

### 3.4 Building a synce4l Tool

1. Download the latest **synce4l** from: <https://github.com/intel/synce4l>  
or use:

```
#git clone http://github.com/intel/synce4l synce4l
```

2. Navigate to the extracted directory and compile the source code:

```
# cd synce4l  
# make
```

**Note:** For synce4l the libnl3-devel package need to be installed.

3. To install the program and related man pages into */usr/local*, run `make install` with root privileges.

```
# make install
```

This enables you to run the tools from any directory.

4. For more details related to installing **synce4l**, go to:

<https://github.com/intel/synce4l>

**Note:** In this version of this document, refer to version 1.1.0 of the synce4l tool.

## 4.0 Configuring the E810-XXVDA4T Using the Linux Kernel Interface

**Note:** The way we communicate with the Linux kernel interface might change in a later revision of the driver.

### 4.1 Introduction

The Linux kernel provides the standard interface for controlling external synchronization pins. Older versions that do not have this feature are not supported. Only versions with the PTP pins interface implemented are supported.

The list of supported operating system can be found in the following document:

<https://cdrdrv2.intel.com/v1/dl/getContent/607252>

To check if the kernel has the required PTP and pin interface, run the following command:

```
# cat /proc/kallsyms | grep ptp_pin
```

After installing the latest E810 network driver, users are able to find the pin interface in the corresponding PTP device under **sysfs**. Users can find it by navigating through multiple paths, depending on the Linux distribution being used.

For a listing of all E810-XXVDA4T adapters, run the following:

```
# grep 000e /sys/class/net/*/device/subsystem_device | awk -F"/" '{print $5}'
enp1s0f0
enp1s0f1
enp1s0f2
enp1s0f3
```

The example above shows one network device with four ports (f0-f3).

To run scripts in this section, set ETH to point to the first port of the adapter:

```
# export ETH=enp1s0f0
```

Or:

```
# export ETH=`grep 000e /sys/class/net/*/device/subsystem_device | awk -F"/" '{print $5}' | head -n 1`
```

**Note:** This alternate command can only be used if one WPC is running in your system. Otherwise, the script must be amended appropriately.

Some scripts also use the PCI\_SLOT. Users can easily set it up by running the following:

```
# export PCI_SLOT=`grep PCI_SLOT_NAME /sys/class/net/$ETH/device/uevent | cut -c 15-`
```

In the following example, the driver exposes the ptp7 device:

```
#ls -R /sys/class/ptp/*/pins/
/sys/class/ptp/ptp7/pins/:
GNSS SMA1 SMA2 U.FL1 U.FL2
```

In the following example, the `ens260f0` net interface exposes pins through the `ptp7` interface:

```
#ls -R /sys/class/net/*/device/ptp*/pins
/sys/class/net/ens260f0/device/ptp/ptp7/pins:
GNSS SMA1 SMA2 U.FL1 U.FL2
```

Users can also run **ethtool -T <interface\_name>** to show the PTP clock number.

```
# ethtool -T <interface_name>
PTP Hardware Clock: 7
```

The E810 only has one hardware timer shared between all ports. As a result, users find the PTP clock number only on Port 0.

If users need to use bonding or DPDK, do not use Port 0, as this prevents the use of Linux PHC API for the device. A better solution is to use any other port for this functionality or to use a virtual function for DPDK.

## 4.2 DPLL Priority

The E810-XXVDA4T automatically switches reference inputs according to the default DPLL priority list, as shown in [Table 6](#).

where:

- Pin index = DPLL device physical pin index
- EEC - DPLL0 = Ethernet equipment clock source from DPLL0 for frequency adjustments., glitchless.
- PPS - DPLL1 = 1PPS generation from DPLL1 for phase adjustments. Glitches allowed. Slower locking.

**Note:** The DPLL priority list can be changed. See [Section 4.11, “Advanced DPLL Configuration”](#).

**Note:** From firmware version 4.20 or newer, the DPLL priority list and the DPLL configuration parameters have been change to meet the ITU-T specs. The firmware will update the needed parameters based on the incoming timing signals. SDP20 is expecting a 10 MHz signal.

**Note:** The input references are checked to ensure that they meet specified criteria before they are fed to the DPLL. Each reference has several monitoring circuits and the one of particular interest is called Precise Frequency Monitor (PFM). By default, input reference is measured in PFM for 10 seconds to avoid disqualifying a reference with jitter/wander, which is still acceptable by standards. This requirement originates from Telcordia GR-1244 standard. Though this requirement is not used in ITU specs, many telecom customers find this feature very useful. Only inputs that meet this 10 seconds of acceptable input are be seen as “valid”. All others are be seen as “invalid”.

**Table 6. DPLL Priority List**

Default Priority	Pin Index	EEC - DPLL0 (Frequency/Glitchless)	Frequency	PPS - DPLL1 (Phase/Glitch Allowed)	Frequency
0	6	1PPS from GNSS (GNSS-1PPS)	1PPS	1PPS from GNSS (GNSS-1PPS)	1PPS
2	5	1PPS from SMA2 (SMA2)	1PPS	1PPS from SMA2 (SMA2)	1PPS
3	4	1PPS from SMA1 (SMA1)	1PPS	1PPS from SMA1 (SMA1)	1PPS
4	1	Reserved	--	1PPS from E810 (CVL-SDP20)	10 MHz
5	0	Reserved	--	1PPS from E810 (CVL-SDP22)	1PPS
6	--	Reserved	--	Reserved	--
7	--	Reserved	--	Reserved	--
8	2	Recovered CLK1 (C827_0-RCLKA)	1.953125 MHz	Recovered CLK1 (C827_0-RCLKA)	1.953125 MHz
9	3	Recovered CLK2 (C827_0-RCLKB)	1.953125 MHz	Recovered CLK2 (C827_0-RCLKB)	1.953125 MHz
10	--	OCXO	20.000 MHz	OCXO	20.000 MHz

### 4.3 External Connectors

External connector configuration is available only on the port that owns the PTP timer. By default, it is Port 0.

The E810-XXVDA4T has four connectors for external 1PPS signals: SMA1, SMA2, U.FL1, and U.FL2

- SMA connectors are bidirectional and U.FL are unidirectional.
- U.FL1 is 1PPS output and U.FL2 is 1PPS input.
- SMA1 and U.FL1 connectors share channel one.
- SMA2 and U.FL2 connectors share channel two.

**Example:**

```
# export ETH=enp1s0f0
echo <function> <channel> > /sys/class/net/$ETH/device/ptp/*/pins/SMA1
(SMA2,U.FL1,U.FL2)
```

where:

*function:* 0 = Disabled  
1 = Rx  
2 = Tx

*channel:* 1 = SMA1 or U.FL1  
2 = SMA2 or U.FL2

## 4.4 Channel 1 Configurations

### 1. SMA1 as 1PPS input:

```
# echo 1 1 > /sys/class/net/$ETH/device/ptp/ptp*/pins/SMA1
# dmesg
[792194.583302] ice 0000:03:00.0: SMA1 RX
[792194.583304] ice 0000:03:00.0: SMA2 <current_state> + U.FL2 <current_state>
```

### 2. SMA1 as 1PPS output:

```
# echo 2 1 > /sys/class/net/$ETH/device/ptp/ptp*/pins/SMA1
# dmesg
[792505.312096] ice 0000:03:00.0: SMA1 TX
[792505.312098] ice 0000:03:00.0: SMA2 <current_state> + U.FL2 <current_state>
```

**Note:** Setting SMA1 as TX automatically enables U.FL1 as RX.

### 3. U.FL1 as 1PPS output:

```
# echo 2 1 > /sys/class/net/$ETH/device/ptp/ptp*/pins/U.FL1
# dmesg
[792745.238452] ice 0000:03:00.0: SMA1 RX + U.FL1 TX
[792745.238453] ice 0000:03:00.0: SMA2 <current_state> + U.FL2 <current_state>
```

**Note:** Setting U.FL1 as a TX automatically enables SMA1 as RX.

### 4. SMA1 as 1PPS input and U.FL1 as 1PPS output:

```
# echo 1 1 > /sys/class/net/$ETH/device/ptp/ptp*/pins/SMA1
echo 2 1 > /sys/class/net/$ETH/device/ptp/ptp*/pins/U.FL1
# dmesg
[27158.812512] ice 0000:03:00.0: SMA1 RX + U.FL1 TX
[27158.812519] ice 0000:03:00.0: SMA2 <current_state> + U.FL2 <current_state>
```

### 5. Disable SMA1:

```
# echo 0 1 > /sys/class/net/$ETH/device/ptp/ptp*/pins/SMA1
# dmesg
[793017.697870] ice 0000:03:00.0: SMA1 + U.FL1 disabled
SMA2 <current_state> + U.FL2 <current_state>
```

**Note:** Users must first disable U.FL1, as it shares the same channel number.

## 6. Disable U.FL1:

```
# echo 0 1 > /sys/class/net/$ETH/device/ptp/ptp*/pins/U.FL1
# dmesg
[793017.697870] ice 0000:03:00.0: SMA1 + U.FL1 disabled
[793017.812519] ice 0000:03:00.0: SMA2 <current_state> + U.FL2 <current_state>
```

**Note:** Users must first disable SMA1, as it shares the same channel number.

**Note:** To compensate for path delay in the network, users can implement phase delay in Channel 1 using command (input pin 4 is SMA1. 7000 is equal to 7 ns):

```
# echo "in pin 4 phase_delay 7000" > /sys/class/net/$ETH/device/pin_cfg
```

**Note:** In VMware, for enabling 1PPS output over SMA1, period file should be configured. Otherwise, input is not valid.

```
# echo 1 0 0 0 100 > /sys/class/net/ptp/device/ptp/ptp*/period
```

**Note:** In VMware, for enabling 1PPS input over SMA, ts2phc needs to be enabled. Otherwise, input is not valid.



## 4.5 Channel 2 Configurations

### 1. SMA2 as 1PPS input:

```
# echo 1 2 > /sys/class/net/$ETH/device/ptp/ptp*/pins/SMA2
# dmesg
[27158.812512] ice 0000:03:00.0: SMA1 <current_state> + U.FL1 <current_state>
[27158.812519] ice 0000:03:00.0: SMA2 RX
```

### 2. SMA2 as 1PPS output:

```
# echo 2 2 > /sys/class/net/$ETH/device/ptp/ptp*/pins/SMA2
# dmesg
[27158.812512] ice 0000:03:00.0: SMA1 <current_state> + U.FL1 <current_state>
[27158.812519] ice 0000:03:00.0: SMA2 TX
```

### 3. U.FL2 as 1PPS input:

```
# echo 1 2 > /sys/class/net/$ETH/device/ptp/ptp*/pins/U.FL2
# dmesg
[27158.812512] ice 0000:03:00.0: SMA1 <current_state> + U.FL1 <current_state>
[27158.812519] ice 0000:03:00.0: SMA2 <current_state> + U.FL2 RX
```

### 4. SMA2 as 1PPS out and U.FL2 as 1PPS in:

```
# echo 2 2 > /sys/class/net/$ETH/device/ptp/ptp*/pins/SMA2
# echo 1 2 > /sys/class/net/$ETH/device/ptp/ptp*/pins/U.FL2
# dmesg
[27158.812512] ice 0000:03:00.0: SMA1 <current_state> + U.FL1 <current_state>
[27158.812519] ice 0000:03:00.0: SMA2 TX + U.FL2 RX
```

### 5. Disable SMA2:

```
# echo 0 2 > /sys/class/net/$ETH/device/ptp/ptp*/pins/SMA2
# dmesg
[27158.812512] ice 0000:03:00.0: SMA1 <current_state> + U.FL1 <current_state>
[27158.812512] ice 0000:03:00.0: SMA2 + U.FL2 disabled
```

**Note:** Users must first disable U.FL2, as it shares the same channel number.

### 6. Disable U.FL2:

```
# echo 0 2 > /sys/class/net/$ETH/device/ptp/ptp*/pins/U.FL2
# dmesg
[27158.812512] ice 0000:03:00.0: SMA1 <current_state> + U.FL1 <current_state>
[27158.812512] ice 0000:03:00.0: SMA2 + U.FL2 disabled
```

**Note:** Users must first disable SMA2 as it shares the same channel number.

**Note:** To compensate for path delay in the network, users can implement phase delay in Channel 1 using command (input pin 4 is SMA1. 7000 is equal to 7 ns):

```
# echo "in pin 4 phase_delay 7000" > /sys/class/net/$ETH/device/pin_cfg
```

**Note:** In VMware, for enabling 1PPS output over SMA2, period file should be configured. Otherwise, input is not valid.

```
# echo 2 0 0 1 0 > /sys/class/net/ptp/device/ptp/ptp*/period
```

**Note:** In VMware, for enabling 1PPS input over SMA, ts2phc needs to be enabled. Otherwise, input is not valid.

## 4.6 Recovered Clocks (G.8261 SyncE Support)

Recovered clocks can be configured using a special **sysfs** interface that is exposed by every port instance. Writing to a **sysfs** under a given port automatically enables a recovered clock from a given port that is valid for a current link speed.

A link speed change requires repeating the steps to enable the recovered clock.

If a port recovered clock is enabled and no higher-priority clock is enabled at the same time, the DPLL starts tuning its frequency to the recovered clock reference frequency enabling G.8261 functionality.

There are two recovered clock outputs from the C827 PHY. Only one pin can be assigned to one of the ports. Re-enabling the same pin on a different port automatically disables it for the previously-assigned port.

**Note:** In the current version, if you switch from a 1PPS clock to recovered clock (SyncE) you might experience up to 200 ns deviation in the 1PPS signal.

**Note:** To configure the recover clocks we suggest to use the `synce4l` utility. `Synce4l` automatically enables, and disables recovered clocks.

1. To enable a recovered clock for a given Ethernet device run the following:

```
# echo <ena> <pin> > /sys/class/net/$ETH/device/phy/synce
```

where:

```
ena: 0 = Disable the given recovered clock pin.
      1 = Enable the given recovered clock pin.

pin: 0 = Enable C827_0-RCLKA (higher priority pin).
      1 = Enable C827_0-RCLKB (lower priority pin).
```

For example, to enable the higher-priority recovered clock from Port 0 and a lower-priority recovered clock from Port 1, run the following:

```
# export ETH0=enp1s0f0
# export ETH1=enp1s0f1
# echo 1 0 > /sys/class/net/$ETH0/device/phy/synce
# dmesg
[27575.495705] ice 0000:03:00.0: Enabled recovered clock: pin C827_0-RCLKA
# echo 1 1 > /sys/class/net/$ETH1/device/phy/synce
# dmesg
[27575.495705] ice 0000:03:00.0: Enabled recovered clock: pin C827_0-RCLKB
```

Disable recovered clocks:

```
# echo 0 0 > /sys/class/net/$ETH0/device/phy/synce
# dmesg
[27730.341153] ice 0000:03:00.0: Disabled recovered clock: pin C827_0-RCLKA
# echo 0 1 > /sys/class/net/$ETH1/device/phy/synce
# dmesg
[27730.341153] ice 0000:03:00.0: Disabled recovered clock: pin C827_0-RCLKB
```

Check recovered clock status:

You can add the current status of the recovered clock to the **dmesg**:

```
#echo dump rclk_status > /sys/kernel/debug/ice/0000:03:00.0/command
# dmesg
[311274.298749] ice 0000:03:00.0: State for port 0, C827_0-RCLKA: Disabled
```

```
[311274.300060] ice 0000:03:00.0: State for port 0, C827_0-RCLKB: Disabled
```

**Note:** In secure boot case, check the `pin_cfg` file. For details, see [Section 4.11.1](#).

## 4.7 External Timestamp Signals

The E810-XXVDA4T can use external 1PPS signals filtered by the DPLL as its own time reference.

When the DPLL is synchronized to the GNSS module or an external 1PPS source, the **ts2phc** tool can be used to synchronize the E810-XXVDA4T time to the 1PPS signal. The configuration file needs to be edited before using the application. You must remember to change `network_interface`, accordingly to his device's name.

**Note:** External Timestamp (extts) event support is only enabled on Port 0.

```
# export ETH=enp1s0f0
# export TS2PHC_CONFIG=/home/<USER>/linuxptp-4.3/configs/ts2phc-generic.cfg
# ts2phc -f $TS2PHC_CONFIG -s generic -m -c $ETH

# cat $TS2PHC_CONFIG
[global]
use_syslog 0
verbose 1
logging_level 7
ts2phc.pulsewidth 100000000
#For GNSS module
#ts2phc.nmea_serialport /dev/gnssX #/dev/gnssX, where X - GNSS device number
#leapfile ../<path_to_.list_leap_second_file>
[<network_interface>]
ts2phc.extts_polarity
rising
```

**Note:** The **phc2sys** tool should not be run at the same time as **ts2phc** using the generic source of ToD (`-s generic`). In the default configuration, **ts2phc** uses hardware-generated timestamps along with the system timer to create correction values. Running the tools in parallel can create a feedback that breaks time synchronization. The **leapfile** option is available but not necessary for the program to run. Also, the default `.leap` file is not compatible with **ts2phc**.

**Note:** You might want filter the 1PPS timestamps till the DPLL locked. See [Section 4.12](#), "1PPS Signals from E810 Device to DPLL".

## 4.8 Periodic Outputs from DPLL (SMA and U.FL Pins)

The E810-XXVDA4T supports two periodic output channels (SMA1 or U.FL1 and SMA2). Channels can be enabled independently and output 1PPS generated by the embedded DPLL. 1PPS outputs are synchronized to the reference input driving the DPLL1. Users can read the current reference signal driving the 1PPS subsystem by running the following command:

```
# dmesg | grep "<DPLL1> state changed" | grep locked | tail -1
[ 342.850270] ice 0000:01:00.0: DPLL1 state changed to: locked, pin GNSS-1PPS
```

The following configurations of 1PPS outputs are supported:

### 1. SMA1 as 1PPS output:

```
# echo 2 1 > /sys/class/net/$ETH/device/ptp/ptp*/pins/SMA1
```

2. U.FL1 as 1PPS output:

```
# echo 2 1 > /sys/class/net/$ETH/device/ptp/ptp*/pins/U.FL1
```

3. SMA2 as 1PPS output:

```
# echo 2 2 > /sys/class/net/$ETH/device/ptp/ptp*/pins/SMA2
```

**Note:** Configurations (1 and 3) or (2 and 3) can be enabled at the same time, but not (1, 2, and 3).

**Note:** In VMware, for enabling 1PPS output over SMA, period file should be configured. Otherwise, input is not valid.

```
SMA1: # echo 1 0 0 0 100 > /sys/class/net/$ETH/device/ptp/ptp*/period
```

```
SMA2: # echo 2 0 0 1 0 > /sys/class/net/$ETH/device/ptp/ptp*/period
```

## 4.9 Reading Status of the DPLL

The E810-XXVDA4T driver exposes a simple **debugfs** interface that enables monitoring of the on-board DPLL device state.

**Note:** The main purpose of this interface is for **debug only**. The **debugfs** interface is not available when using Secure Boot option. All of the information is available using the **pin\_cfg** or **dpll\_<X>\_ref\_pin/dpll\_<X>\_state** option as detailed in [Section 4.11, "Advanced DPLL Configuration"](#).

```
# export ETH=enp1s0f0
# export PCI_SLOT=`grep PCI_SLOT_NAME /sys/class/net/$ETH/device/uevent | cut -c 15-`
#
# cat /sys/kernel/debug/ice/0000:82:00.0/cgu
Found ZL80032 CGU
DPLL Config ver: 1.3.0.1
DPLL FW ver: 6201

CGU Input status:
      input (idx) | state | priority |
      -----|-----|-----|
      EEC (0) | PPS (1) | eSync fail |
      -----|-----|-----|
      CVL-SDP22 (0) | invalid | 255 | 5 | N/A |
      CVL-SDP20 (1) | invalid | 255 | 4 | N/A |
      C827_0-RCLKA (2) | invalid | 8 | 8 | N/A |
      C827_0-RCLKB (3) | invalid | 9 | 9 | N/A |
      SMA1 (4) | invalid | 3 | 3 | N/A |
      SMA2/U.FL2 (5) | invalid | 2 | 2 | N/A |
      GNSS-1PPS (6) | valid | 0 | 0 | N/A |

EEC DPLL:
Current reference: GNSS-1PPS
Status:          locked_ho_acq

PPS DPLL:
Current reference: GNSS-1PPS
Status:          locked_ho_acq
Phase offset [ps]: -717
```

The first section of the log shows the status of CGU inputs (references), including its index number. Active references currently selected are listed in [Section 4.2](#). EEC Ethernet equipment clock (DPLL0) skips the 1PPS signal received on the CVL-SDP20 pin.

The second section lists all internal DPLL units. ECC (DPLL0) driving the internal clocks and PPS (DPLL1) driving all 1PPS signals.

The E810-XXVDA4T supports embedded sync (eSync), including embedded pulse per second (ePPS),

The third section talks about the eSync, if it is enabled, as detailed in [Section 4.11, "Advanced DPLL Configuration"](#).

Lock times for each of the DPLLs are different and are subject to change and can take a long time to lock depending on their initial synchronization.

Status options: **invalid**, **freerun**, **locked**, **locked\_ho\_acq** (locked and holdover acquired), **holdover**, and **uninitialized**.

The Phase offset value helps to find out how well the PPS DPLL is synchronized (in 1 ps unit).

**Note:** The DPLL firmware version should be 6201 for all production units. If you have a different version, please contact your Intel representative.

**Note:** CGU information is unavailable when you are using PTP on VMware OS.

## 4.10 DPLL Monitoring

In the default configuration, the E810-XXVDA4T driver enables monitoring of the DPLL events and reports state changes in the default system log (**dmesg**) with the WARN level independently for each of the DPLL units.

DPLLs start in a holdover mode and enter an unlocked and locked state when a valid reference input is enabled. If the current input becomes invalid, DPLLs change state to holdover. When the reference reappears (or a different valid input is present), the DPLL state changes to the unlocked state and locks to a new signal.

```
# dmesg | grep "state changed"
[23.740121] ice 0000:01:00.0: <DPLL0> state changed to: holdover, pin CVL-SDP22
[23.740833] ice 0000:01:00.0: <DPLL1> state changed to: holdover, pin CVL-SDP22
#GNSS signal appeared
[57.857575] ice 0000:01:00.0: <DPLL0> state changed to: unlocked, pin GNSS-1PPS
[57.858088] ice 0000:01:00.0: <DPLL1> state changed to: unlocked, pin GNSS-1PPS
[119.810415] ice 0000:01:00.0: <DPLL0> state changed to: locked, pin GNSS-1PPS
[178.818056] ice 0000:01:00.0: <DPLL1> state changed to: locked, pin GNSS-1PPS
#GNSS signal lost:
[18.833552] ice 0000:01:00.0: <DPLL0> state changed to: holdover, pin GNSS-1PPS
[18.834065] ice 0000:01:00.0: <DPLL1> state changed to: holdover, pin GNSS-1PPS
#GNSS signal re-appeared:
[19.825608] ice 0000:01:00.0: <DPLL0> state changed to: unlocked, pin GNSS-1PPS
[19.826122] ice 0000:01:00.0: <DPLL1> state changed to: unlocked, pin GNSS-1PPS
[21.841638] ice 0000:01:00.0: <DPLL0> state changed to: locked, pin GNSS-1PPS
[21.850270] ice 0000:01:00.0: <DPLL1> state changed to: locked, pin GNSS-1PPS
```

Software DPLL monitoring can be enabled (on) or disabled (off) by using the **ethtool** command in the Linux kernel.

```
# export ETH=ens801f0

ethtool --show-priv-flags $ETH

Private flags for ens801f0:

link-down-on-close      : off
fw-lldp-agent          : off
```

```
channel-inline-fd-mark      : off
channel-pkt-inspect-optimize : on
channel-pkt-clean-bp-stop   : off
channel-pkt-clean-bp-stop-cfg: off
vf-true-promisc-support    : off
mdd-auto-reset-vf         : off
vf-vlan-pruning           : off
legacy-rx                 : off
dp11_monitor              : on
itu_g8262_filter_used     : off
allow-no-fec-modules-in-auto : off
```

Enabling DPLL monitoring:

```
ethtool --set-priv-flags $ETH dp11_monitor on
```

Disabling DPLL monitoring:

```
ethtool --set-priv-flags $ETH dp11_monitor off
```

**Note:** With this command you will be able to disable the driver DPLL monitoring however the E810 FW itself does some DPLL configuration and monitoring as well that **cannot** be disabled.

## 4.11 Advanced DPLL Configuration

### 4.11.1 pin\_cfg User Readable Format

The DPLL on the E810-XXVDA4T offer some advanced configuration options. These options are not needed on regular applications and can cause problems. Please use these commands with extra care. The DPLL will go back to the default values after a power cycle of the adapter.

The E810-XXVDA4T supports embedded sync (eSync), including embedded pulse per second (ePPS), but not embedded pulse per two seconds (ePP2S).

Timing signals on the SMAs can be configured as inputs or outputs, typically configured for one pulse per second (1PPS) operation, but they will support a 10 MHz signal (with or without the embedded 1PPS eSync).

**Note:** Do not change any other output pin than 0 and 1.

The Ref-sync pair (e\_ref\_sync) feature uses two DPLL inputs, one is used as a reference clock (typically higher than 1 KHz) and a sync signal (1PPS). This feature allows a wider loop bandwidth resulting in much faster DPLL lock time and was also empirically found to be required to pass ITU-T certification. This Ref-sync\_pair feature can be enabled on SMA or SDP (input pin 1 for SDP (pairing pin 0 & 1) and pin 5 for SMA (pairing pin 4 & 5))

**Note:** In the *pin\_cfg* the eSync/Ref-sync column 0: both eSync and e\_ref\_sync are disabled, 1: eSync is enabled, 2: Ref-sync\_pair is enabled.

To check the DPLL pin configuration:

```
# cat /sys/class/net/ens4f0/device/pin_cfg

in
| pin| enabled| state| freq| phase_delay| eSync/Ref-sync| DPLL0 prio| DPLL1 prio|
| 0| 1| invalid| 1| 0| 0| 255| 5|
| 1| 1| invalid| 1| 0| 2| 255| 4|
| 2| 1| invalid| 1953125| 0| 0| 8| 8|
| 3| 1| invalid| 1953125| 0| 0| 9| 9|
| 4| 1| invalid| 1| 7000| 0| 3| 3|
| 5| 1| invalid| 1| 7000| 2| 2| 2|
| 6| 1| valid| 1| 0| 0| 0| 0|

out
| pin| enabled| dpll| freq| esync|
| 0| 1| 1| 1| 0|
| 1| 1| 1| 1| 0|
| 2| 1| 0| 156250000| 0|
| 3| 1| 0| 156250000| 0|
| 4| 1| 1| 1| 0|
| 5| 1| 1| 1| 0|
```

In the “in” table, the pin numbers are referred from the DPLL Priority See [Section 4.2, “DPLL Priority”](#).

In the “out” table pin 0 is SMA1 pin 1 is SMA2, all the other values do not modify.

#### Changing the DPLL priority list:

```
# echo "prio <prio_value> dpll <dpll_index> pin <pin_index>" > \ /sys/class/net/$ETH/
device/pin_cfg
```

where:

- prio\_value* = Desired priority of configured pin [0-9]
- dpll\_index* = Index of DPLL being configured [0:EEC (DPLL0), 1:PPS (DPLL1)]
- pin\_index* = Index of pin being configured [0-6]

**Note:** A *prio value* 255 disables the input for synchronization.

#### Example:

Set priority 1 for pin 3 on DPLL 0:

```
# export ETH=enp1s0f0
# echo "prio 1 dpll 0 pin 3" > /sys/class/net/$ETH/device/pin_cfg
```

#### Changing input/output pin configuration:

```
# echo "<direction> pin <pin_index> <config>" > /sys/class/net/$ETH/device/pin_cfg
```

where:

- direction* = pin direction being configured [“in”: input pin, “out”: output pin]
- pin index* = index of pin being configured [for in 0-6 (see DPLL priority section); for out 0: SMA1 1: SMA2]

config = list of configuration parameters and values:

```
[ "freq <freq_value_in_Hz>",
  "phase_delay <phase_delay_value_in_ns>" // NOT used for out,
  "esync <0:disabled, 1:enabled>"
  "e_ref_sync <0:disabled, 1:eSync enabled 2:Ref_Sync enabled>"
  "enable <0:disabled, 1:enabled>" ]
```

**Note:** The **eSync** setting has meaning only with the 10 MHz frequency, you need to have eSync to have the same setting in both ends of the SMA. eSync can be enabled only for the SMA's (input pin 4 / 5 and output pin 0 / 1)

**Example:**

```
# export ETH=enp1s0f0
```

Set freq to 10 MHz on input pin 4: DPLL will lock only if 10 MHz signals arrive on SMA1 and it has been enabled for input.

```
# echo "in pin 4 freq 10000000" > /sys/class/net/$ETH/device/pin_cfg
```

Set freq to 10 MHz on output pin 1: SMA2 will drive 10 MHz signal with embedded 1PPS if it has been enabled for output.

```
# echo "out pin 1 freq 10000000 esync 1" > /sys/class/net/$ETH/device/pin_cfg
```

Disable input pin 2: DPLL will ignore anything on pin 2.

```
# echo "in pin 2 enable 0" > /sys/class/net/$ETH/device/pin_cfg
```

Set Ref-Sync\_pair on pin 0 & 1 (SDPs)

```
# echo "in pin 1 e_ref_sync 2" > /sys/class/net/$ETH/device/pin_cfg
```

Set freq to 1 Hz (1PPS) on input pin 4: DPLL will lock only if 1 Hz signals arrive on SMA1 and it has been enabled for input with phase delay of 4 ns.

```
# echo "in pin 4 freq 1 phase_delay 4000" > /sys/class/net/$ETH/device/pin_cfg
```

### 4.11.2 **dpll\_<X>\_ref\_pin/dpll\_<X>\_state Machine Readable Interface (X = 0 / 1)**

```
# export ETH=enp1s0f0
```

To find out which pin the DPLL0 (EEC DPLL) is locked on, check the `dpll_0_ref_pin`:

```
# cat /sys/class/net/$ETH/device/dpll_0_ref_pin
```

To check the state of the DPLL0 (EEC DPLL), check the `dpll_0_state`:

```
# cat /sys/class/net/$ETH/device/dpll_0_state
```

```
DPLL_UNKNOWN = -1,
DPLL_INVALID = 0,
DPLL_FREERUN = 1,
DPLL_LOCKED = 2,
DPLL_LOCKED_HO_ACQ = 3,
DPLL_HOLDOVER = 4
```

To find out which pin the DPLL1 (PPS DPLL) is locked on, check the `dpll_1_ref_pin`:



```
# cat /sys/class/net/$ETH/device/dpll_1_ref_pin
```

To check the state of the DPLL1 (PPS DPLL), check the `dpll_1_state`:

```
# cat /sys/class/net/$ETH/device/dpll_1_state
```

The `dpll_0_state` interface used by **synce4I** as well.

**Note:** The user application can monitor the `dpll_<X>_state` and `dpll_<X>_ref_pin` to detect the DPLL status changes. These changes will be visible in the **dmesg** as well.

**Note:** The application can also check the DPLL name in the `dpll_<X>_name` file.

## 4.12 1PPS Signals from E810 Device to DPLL

The E810-XXVDA4T implements two 1PPS signals coming out of the MAC (E810 device) to the DPLL. They serve as the frequency reference (CVL-SDP20) and as both phase and frequency reference (CVL-SDP22) signals.

To enable a periodic output, write five integers into the file: channel index, start time seconds, start time nanoseconds, period seconds, and period nanoseconds. To disable a periodic output, set all the seconds and nanoseconds values to zero.

**Note:** Intel recommends to use a 10 MHz or 1 kHz signal on SDP20 together with the 1 Hz signal from SDP22. For this you will need to configure both the DPLL input pin 1 to the same frequency. See [Section 4.11, "Advanced DPLL Configuration"](#).

1. To enable the frequency reference pin 10 MHz (CVL-SDP20):

```
# echo 1 0 0 0 100 > /sys/class/net/$ETH/device/ptp/ptp*/period
(# echo "in pin 1 freq 10000000" > /sys/class/net/$ETH/device/pin_cfg )
```

2. To enable the frequency reference pin 1 KHz (CVL-SDP20):

```
# echo 1 0 0 0 1000000 > /sys/class/net/$ETH/device/ptp/ptp*/period
(# echo "in pin 1 freq 1000" > /sys/class/net/$ETH/device/pin_cfg )
```

3. To enable the phase and frequency reference pin with 1 Hz signal (CVL-SDP22):

```
# echo 2 0 0 1 0 > /sys/class/net/$ETH/device/ptp/ptp*/period
```

4. To disable the phase reference pin (CVL-SDP20):

```
# echo 1 0 0 0 0 > /sys/class/net/$ETH/device/ptp/ptp*/period
```

5. To disable the phase and frequency reference pin (CVL-SDP22):

```
# echo 2 0 0 0 0 > /sys/class/net/$ETH/device/ptp/ptp*/period
```

**Note:** Enabling the phase and frequency reference signal (CVL-SDP22) on the adapter without external reference (**ptp4I**) is not recommended and might cause a frequency drift.

**Note:** In VMware, for enabling 1PPS input over SMA, `ts2phc` needs to be enabled. Otherwise, input is not valid.

## 4.13 1PPS Signals from the DPLL to E810 Device

The DPLL automatically delivers two 1PPS signals to the E810 device on pin 21 and 23. These signals can be used to synchronize the E810 to the DPLL phase with the `ts2phc` program. The E810 will capture the timestamp when the 1PPS signal arrives.

## 4.14 GNSS Module Interface

Intel recommends disabling UART1 and UART2 interfaces on the GNSS receiver. To do that, use:

1. Disable UART1 in RAM, and Flash:

```
# ubxtool -v 1 -w 1 -P 29.20 -z CFG-UART1-ENABLED,0,5
```

Or run:

```
# echo -ne "\xb5\x62\x06\x8a\x09\x00\x00\x05\x00\x00\x05\x00\x52\x10\x00\x05\x80"
> /dev/gnssX
```

2. Disable UART2 in RAM, and Flash:

```
# ubxtool -v 3 -w 1 -P 29.20 -z CFG-UART2-ENABLED,0,5
```

Or run:

```
# cat /dev/gnssX //Terminal 1

# echo -ne "\xb5\x62\x06\x8a\x09\x00\x00\x05\x00\x00\x05\x00\x53\x10\x00\x06\x83"
> /dev/gnssX
```

The E810-XXVDA4T driver implements GNSS interfaces for receiving NMEA messages from the optional GNSS module. The interface can be found in `/dev/gnssX`, where `X` is the GNSS interface.

If you have only one adapter installed, the GNSS interface number will always be `/dev/gnss0`.

To associate the GNSS interface number with the network interface name if you have multiple adapters in a system, use the following command:

```
# ls /sys/class/net/*/device/gnss/*

/sys/class/net/ens1f0/device/gnss/gnss1:
dev device power subsystem type uevent
/sys/class/net/ens2f0/device/gnss/gnss0:
dev device power subsystem type uevent

# cat /dev/gnss0
$GNRMC,182805.00,A,0.0,N,0.0,E,0.082,,050321,,,D,V*14
$GNVTG,,T,,M,0.082,N,0.152,K,D*34
$GNGGA,182805.00,0.0,N,0.0,E,2,12,0.57,11.1,M,32.7,M,,0000*7D
$GNGSA,A,3,18,20,26,23,16,29,07,15,27,10,,,1.07,0.57,0.90,1*09
$GNGSA,A,3,81,79,72,82,80,78,65,88,87,,,1.07,0.57,0.90,2*0C
$GNGSA,A,3,02,30,04,36,11,,,,,,,,,1.07,0.57,0.90,3*0E
[...]
```

**Note:** If two applications, like **gpsd** and **ts2phc** need to be run at the same time, you might encounter issues regarding one application taking over the GNSS interface. A workaround would be to run **gpspipe** on local port while **gpsd** is running in the background, and modify the config file of **ts2phc** to use a local port, where **socat** and **gpspipe** provide NMEA messages through TCP:

```
# socat EXEC:'gpspipe -r' TCP-LISTEN:2948,reuseaddr,fork

# cat configs/ts2phc-nmea.cfg

...
ts2phc.nmea_remote_host 127.0.0.1
ts2phc.nmea_remote_port 2948
...
```

**ts2phc** is now capable of using the local port 2948 to retrieve NMEA messages.

**Note:** Make sure that you are using `/dev/gnssX` in your `.cfg` file for **linuxptp** if using the **ts2phc** tool.

**Note:** The QS samples contain prototype firmware, which expired on December 26, 2021. Pre-production samples in use at that time stop (no longer sync/lock to GNSS) and output a text message stating that the firmware has expired. An update is required to resolve. See more details in the Dear Customer Letter.

**Note:** Intel recommends disabling UART1 and UART2 interfaces (see [Appendix A](#)).

## 4.15 GNSS Advanced Features

To achieve the best GM, additional configuration might be required, like survey-in, cable delay, antenna setting, and so on. This requires additional packages under Linux.

In addition to using the **cat** command, you can use 3rd party APIs to improve the position accuracy and timing accuracy, as well as optimize the overall performance of the GNSS module. One of the most popular GNSS Linux APIs is **gpsd**, which is Open Source and is support by community at:

<https://gpsd.gitlab.io/gpsd/index.html>

The **gpsd** API follows chip vendor original specifications and fully integrates into a rich GUI tool, **pygpsclient**. Furthermore, **gpsd** provides the command line tool **ubxtool**, which support all original configuration commands.

The optional GNSS module inside the E810-XXVDA4T uses u-Blox 9-series chip ZED-F9T-00B. Before you start yours first investigation, we suggest you study most popular questions at:

<https://gpsd.io/faq.html#willitwork>

### 4.15.1 Prerequisites and Steps to Fully Enable GNSS Features

#### Prerequisites:

- Python3.9+ and pip3 20.2+
- **scons** 4.2.0 or later

**Note:** Ensure that these components are installed correctly before any other step. During the installation process, ensure that there are no hidden error messages. After the installation, check if **scons** is present.

```
(# scons -v)
```

**Note:** Before installing **gpsd** on your system, ensure that all parts of any previous installation have been removed. Do not mix **gpsd** parts from different sources. The **gpsd** clients and the server must be of the same version.

#### Steps to prepare system and install **gpsd**:

**Note:** For additional information, refer to <https://gpsd.io/installation.html>.

1. If you cannot find the `/dev/gnss0` file, ensure that you are using the E810-XXVDA4T with the optional GNSS installed and the latest driver and NVM (see [Section 3.1](#)).
2. If you receive any error message from the above two commands, follow the trouble shooting guide to solve OS and kernel dependencies:

[https://gpsd.io/installation.html#\\_check\\_that\\_your\\_system\\_configuration\\_will\\_allow\\_gpsd\\_to\\_work](https://gpsd.io/installation.html#_check_that_your_system_configuration_will_allow_gpsd_to_work)

3. A minimum build of **gpsd** can run near bare metal; C runtime support is the only requirement. The test clients and various additional features have additional prerequisites found at:

[https://gpsd.io/installation.html#\\_check\\_your\\_installation\\_prerequisites](https://gpsd.io/installation.html#_check_your_installation_prerequisites)

**Note:** It is important to install system dependencies using your system package manager first, before installing SCons or Python dependencies.

**Note:** On some systems, GPSD might not work properly as a service out of the box. If that is the case, check that your *systemd* configuration files are set correctly.

4. You might need to add additional repositories to get dependencies, based on the distribution you are using. For example, for Red Hat 8 use commands:

```
# subscription-manager repos --enable codeready-builder-for-rhel-8-$(arch)-rpms

# sudo dnf install https://dl.fedoraproject.org/pub/epel/epel-release-latest-8.noarch.rpm
```

5. Suggested dependencies to install. Some dependencies might not be needed if all features are not needed.

#### For Red Hat 8:

```
# dnf -y install cairo-devel pkg-config python3-devel libffi-devel gobject-
introspection-devel cairo-gobject-devel gtk3-devel libtinfo.so.5 dbus libusb qt5-
qtnetworkauth llvm-toolset clang-analyzer libsmi* python3-pycodestyle python3-
flake8 python3-pyflakes cppcheck dia valgrind asciidoctor dbus gnuplot libusb
ncurses pps-tools* qt-creator pygobject3* python3-pyserial python3-serial gtk3*
python3-matplotlib python-matplotlib* libtinfo5 libcairo2 libcairo2-dev libevent-
devel python39-devel qt5-qtnetworkauth llvm-toolset clang-analyzer libsmi*
python3-pycodestyle python3-flake8 python3-pyflakes cppcheck dia valgrind
asciidoctor dbus gnuplot libusb ncurses pps-tools* qt-creator pygobject3* gtk3*
python3-matplotlib* libtinfo5 python-pyserial texlive-full python3-gps --skip-
broken
```

6. Install Python 3.9. For now, Python older than 3.9, and newer than 3.9 (like 3.10.6) are not recommended due to incompatible libraries. Version 3.9.14 is best. Install Python with `make altinstall`. You can also try the Python virtual environment, if you are confident in what you are doing.

7. Suggested Python dependencies:

```
# python3.9 -m pip install pycairo pygobject matplotlib serial rouge coverage python-can
pyserial gps wheel Pillow pygnssutils requests urllib3 idna charset-normalizer certify pyrtcm
pynmeagps pyubx2
```

8. Setup your PYTHONPATH variable to `/usr/local/lib/python3.9/site-packages` (most common), or wherever you have your python libraries, and install **scons**:

```
# python setup.py install
```

9. Install **gpsd**:

```
# git clone https://gitlab.com/gpsd/gpsd.git
# cd gpsd
# scons -c && scons
# scons udev-install
(optionsl) # python3.9 -m pip install pygpsclient
```

10. Check **gpsd** version with `# gpsd -V`, and check **ubxtool** version with `# ubxtool -V`. If you receive an error, at this point the usual reason is incorrectly set PATH and PYTHONPATH variable - make sure they are pointing to the correct directories.

11. (Optional) Configure the **gpsd** service daemon:

- a. Edit `/etc/sysconfig/gpsd` (depends on the kernel) and add `OPTIONS="-G -n -p /dev/gnssX"` to include the GNSS interface.

12. (Optional) Restart the **gpsd** service daemon and check its status (`/dev/gnss0` as an example).

```
#systemctl restart gpsd
#systemctl status gpsd
? gpsd.service - GPS (Global Positioning System) Daemon
   Loaded: loaded (/usr/lib/systemd/system/gpsd.service; enabled; vendor preset:
   enabled)
   Active: active (running) since Mon 2022-10-31 10:09:59 CST; 1s ago
     Process: 1856694 ExecStart=/usr/local/sbin/gpsd $GPSD_OPTIONS $OPTIONS $DEVICES
   (code=exited, status=0/SUCCESS)
    Main PID: 1856695 (gpsd)
       Tasks: 1 (limit: 3355442)
      Memory: 904.0K
    CGroup: /system.slice/gpsd.service
           ??1856695 /usr/local/sbin/gpsd -G -n -p /dev/gnss0
```

**Setup compliance verification:**

Before starting the **gpsd** APIs, the Antenna setup and GNSS firmware must be done.

- Antenna compliance:
  - All the GNSS applications’ performance is expected to get good quality of antenna signal so the software APIs can run on top of stable NMEA sentences.
  - [Table 7](#) shows the Antenna frequency band for ZED-F9T-00B. You should follow the original vendor specification including supported band and circular polarization (the ZED-F9T-00B uses right-hand circular polarization or RHCP).

**Table 7. Supported GNSS and Signals on ZED-F9T=00B**

GPS / QZSS	GLONASS	Galileo	BeiDou	NavIC
L1C/A (1575.420 MHz)	L1OF (1602 MHz + k*562.5 kHz, k=-7,...,6)	E1-B/C (1575.420 MHz)	B1I (1561.098 MHz)	-
			B1C (1575.420 MHz) <sup>1</sup>	
L2C (1227.600 MHz)	L2OF (1246 MHz + k*437.5 kHz, k=-7,...,6)	E5b (1207.140 MHz)	B2I (1207.140 MHz)	-

1. B1I and B1C not to be enabled concurrently.

- Leverage GPSD APIs to improve the E810-XXVDA4T with the optional GNSS accuracy:
  - **gpsctl**
    - **gpsctl** can switch a dual-mode GPS between NMEA and vendor-binary modes. The **gpsctl** API needs the `gpsd.socket` service daemon running. Following is a basic device identification example. You can use `gpsctl -help` to get all command details.
    - With proper GPSD installation, the **gpsctl** can export terminal interface, as follows:

```
# gpsctl /dev/gnss0
```

where `/dev/gnss0` is identified as a u-Blox SW EXT CORE 1.00 (3fda8e), HW 00190000 at 9600 baud.

## — ubxtool

**ubxtool** is an original vendor-supported tool that can make use of u-Blox vendor commands on support protocol version 29.20 to ZED-F9T-00B. If the 5G deploy environment does not allow you to use the Desktop environment, you can consider **ubxtool** as efficient CLI for local and remote access.

- The default setting of the E810-XXVDA4T configuration minimizes NMEA sentence message for better timing usage. Only "GNRMC" and "GNGGA" are needed for 5G timing usage. For better understanding of NMEA sentence focus and its purpose, refer to:

<https://w3.cs.jmu.edu/bernstdh/web/common/help/nmea-sentences.php>

- The ZED-F9T-00B module requires protocol 29.20, so it needs **ubxtool** v3.24+. Use the following command to double check the **ubxtool** you install:

```
# ubxtool -V
ubxtool: Version 3.25.1~dev
```

- Get u-Blox protocol version for your GNSS device

```
# ubxtool -t -w 5 -v 1 -p MON-VER
ubxtool: poll MON-VER

sent:
1667189283.3474
UBX-MON-VER:
  Poll request

1667189285.2572
UBX-MON-VER:
  swVersion EXT CORE 1.00 (3fda8e)
  hwVersion 00190000
  extension ROM BASE 0x118B2060
  extension FWVER=TIM 2.20
  extension PROTVER=29.20
  extension MOD=ZED-F9T
  extension GPS;GLO;GAL;BDS
  extension SBAS;QZSS
  extension NAVIC
WARNING: protVer is 10.00, should be 29.20. Hint: use option "-P 29.20"
```

### 4.15.2 GNSS Receiver Configuration Layers in the E810-XXVDA4T

Once you confirm that **gpsd** is running, either in the foreground or as a service, **ubxtool** can be run. The **ubxtool** command is capable of using five different "layers" to read from and save configuration. These layers are:

- 0 - RAM — Responsible for reading configuration on the E810-XXVDA4T.
- 1 - Battery Backed RAM (BBR) — Responsible for saving single configuration items on the E810-XXVDA4T.
- 2 - Flash Layer
- 5 - RAM, and FLASH — Responsible for saving configuration to two memory types with one command. Use this layer if you would like to write your configuration settings to RAM and FLASH at the same time.

- 7 - Default configuration

The E810-XXVDA4T uses Layer 0 (RAM) to read RAM configuration from the device, and Layer 1 (BBR) to save configuration to the RAM of the device. If layers are used incorrectly, the **ubxtool** command will fail with a UBX-ACK-NAK response. The E810-XXVDA4T also uses Layer 2 (FLASH), and Layer 7 (default configuration).

If you do not state the layer, the **-z** flag (change configuration item) writes to FLASH and RAM, while the **-g** flag reads from all the possible layers.

For more information about the use of **ubxtool**, and to get a list of possible configuration items, use the following command:

```
# ubxtool -h -v 3
```

### 4.15.3 Perform Antenna Status Check New Location Setup

The current active antenna status can be determined by polling the *UBX-MON-RF* message. If an antenna is connected, the initial state after power-up is "Active Antenna OK".

The antenna supervisor can be configured through the *CFG-HW-ANT\_\** configuration items. The current configuration of the active antenna supervisor can also be checked by polling the related *CFG-HW\_ANT\_\** configuration items.

Antenna status (as reported in the *UBX-MON-RF* and *UBX-INF-NOTICE* messages) is not reported unless the antenna voltage control has been enabled. To enable it:

```
# ubxtool -v 1 -P 29.20 -z CFG-HW-ANT_CFG_VOLTCTRL,1
sent:
UBX-CFG-VALSET:
version 0 layer 0x7 transaction 0x0 reserved 0
layers (ram bbr flash) transaction (Transactionless)
item CFG-HW-ANT_CFG_VOLTCTRL/0x10a3002e val 1

UBX-ACK-ACK:
ACK to Class x06 (CFG) ID x8a (VALSET)
```

To check your antenna status:

```
# ubxtool -v 1 -P 29.20 -p MON-RF
ubxtool: poll MON-RF

sent:
UBX-MON-RF:
Poll request

UBX-MON-RF:
version 0 nBlocks 2 reserved1 0 0
blockId 0 flags x0 antStatus 2 antPower 1 postStatus 0 reserved2 0 0 0 0
noisePerMS 71 agcCnt 5616 jamInd 18 ofsI 17 magI 147 ofsQ 2 magQ 139
reserved3 0 0 0
blockId 1 flags x0 antStatus 2 antPower 1 postStatus 0 reserved2 0 0 0 0
noisePerMS 45 agcCnt 5265 jamInd 26 ofsI 12 magI 164 ofsQ 5 magQ 160
reserved3 0 0 0
```

Status of the antenna supervisor state machine (0x00=INIT,0x01=DONTKNOW,  
0x02=OK,0x03=SHORT,0x04=OPEN)

Current power status of antenna (0x00=OFF,0x01=ON,0x02=DONTKNOW)

#### 4.15.4 Enabling and Disabling Additional Constellations

Before enabling survey-in functionality to achieve precise time information, it is beneficial to enable additional constellations. With more constellations enabled, the GNSS receiver can access more satellites, allowing better precision with good sky view. It is up to the user which constellations should be enabled. It is recommended to enable at least the GALILEO constellation for better timing capabilities.

To enable constellations in RAM, use the following commands (this will take a few minutes for the receiver to see constellations):

```
# ubxtool -P 29.20 -e BEIDOU,1 -w 2 - Chinese constellation
# ubxtool -P 29.20 -e GLONASS,1 -w 2 - Russian constellation
# ubxtool -P 29.20 -e GPS,1 -w 2 - American constellation
# ubxtool -P 29.20 -e SBAS,1 -w 2 - Regional Satellite-based Augmentation Systems
# ubxtool -P 29.20 -e GALILEO,1 -w 2 - European constellation
```

To disable GLONASS constellation in RAM, use the following command:

```
# ubxtool -P 29.20 -d GLONASS,1 -w 2
```

To check enabled constellations in all layers, use the following command:

```
# ubxtool -v 1 -P 29.20 -g CFG-SIGNAL -v 1 -w 2
```

#### 4.15.5 Perform Survey-In for New Location Setup

To achieve precise time information, the GNSS module needs to do a process “survey-in”. This process can take up to 24 hours to achieve best precision. Depending on the antenna placement and view of the sky, you might not be able to achieve certain survey-in precision.

It is suggested to start with 50 m precision and 600-second survey in time.

**Note:** The 50 m precision and the minimum 600-second survey in time is just an example (or a starting point). Most likely you will want to use better a precision value and a longer survey-in time for better accuracy. This depends on your location, sky view, signal quality, and your antenna.

For survey-in, use the `ubxtool -t -w 5 -P 29.20 -v 1 -e SURVEYIN,<time_in_sec> , <precision_in_mm>` command:

```
# ubxtool -t -w 5 -P 29.20 -v 1 -e SURVEYIN,600,50000
ubxtool: enable SURVEYIN,600,50000

sent:
1667189015.3247
UBX-CFG-TMODE3:
  version 0 reserved1 0 flags x1
  ecefXOrLat 0 ecefYOrLon 0 ecefZOrAlt 0
  ecefXOrLatHP 0 ecefYOrLonHP 0 ecefZOrAltHP 0
  reserved2 0 fixedPosAcc 0 svinMinDur 600 svinAccLimit 50000
  reserved3 0 0
```



### 4.15.6 Check Survey-In Status

You can create a while-loop to track survey-in status before going to the next step. The following **ubxtool** command can be a major portion to get survey-in status/result (the last line, `valid 1 active 0`, indicates that survey-in is successful):

```
#ubxtool -t -w 5 -P 29.20 -v 1 -p TIM-SVIN
1669003112.3786
UBX-TIM-SVIN:
  dur 1378 meanX -303002288 meanY 492404391 meanZ 268440058 meanV 2024749696
  obs 1379 valid 1 active 0
```

After a successful procedure, this command will display XYZ coordinates, required later to save the current position to FLASH layer. Make sure to write down meanX, meanY, and meanZ coordinates in a text file.

### 4.15.7 Saving Survey-In Position to FLASH

Once the survey-in process is finished, and precise position is known to the receiver, ensure that the position is saved in the FLASH layer. This way, the found position of the receiver inside memory is kept between power-cycles of the adapter. First, check the position found by the survey-in procedure, then update the XYZ coordinates accordingly.

1. Update X coordinate in FLASH and RAM, using value from the first command:

```
# ubxtool -v 1 -P 29.20 -z CFG-TMODE-ECEF_X,<value>,5 -w 1
```

2. Update Y coordinate in FLASH and RAM, using value from the first command:

```
# ubxtool -v 1 -P 29.20 -z CFG-TMODE-ECEF_Y,<value>,5 -w 1
```

3. Update Z coordinate in FLASH and RAM, using value from the first command:

```
# ubxtool -v 1 -P 29.20 -z CFG-TMODE-ECEF_Z,<value>,5 -w 1
```

4. Set TMODE-MODE (0 - disabled, 1 - survey-in, 2 - fixed) to fixed in BBR and FLASH layers:

```
# ubxtool -v 1 -P 29.20 -z CFG-TMODE-MODE,2,5 -v 1 -w 1
```

5. Check, if TMODE-MODE, and coordinates were saved correctly to the FLASH:

```
# ubxtool -v 1 -P 29.20 -g CFG-TMODE-MODE,0 -v 1 -w 2
# ubxtool -v 1 -P 29.20 -g CFG-TMODE-ECEF_X,2 -v 1 -w 2
# ubxtool -v 1 -P 29.20 -g CFG-TMODE-ECEF_Y,2 -v 1 -w 2
# ubxtool -v 1 -P 29.20 -g CFG-TMODE-ECEF_Z,2 -v 1 -w 2
```

### 4.15.8 Simulate Antenna Removal

Sometimes you may want to check the functionality and simulate what happens if the antenna is removed, with these commands you can check that without physically unplugging the antenna cable.

```
# ubxtool -P 29.20 -w 1 -v 3 -z CFG-NAVSPG-INFIL_NCNTHRS,50,1
```

Or run:

```
# echo -ne "\xb5\x62\x06\x8a\x09\x00\x00\x01\x00\x00\x00\xaa\x00\x11\x20\x32\xa7\x28" > /dev/gnssX
```

To restore it, use:

```
# ubxtool -P 29.20 -w 1 -v 3 -z CFG-NAVSPG-INFIL_NCNTHRS,0,1
```

Or run:

```
# cat /dev/gnssX //Terminal 1

# echo -ne "\xb5\x62\x06\x8a\x09\x00\x00\x01\x00\x00\xaa\x00\x11\x20\x00\x75\xf6" > /dev/gnssX //Terminal2
```

#### 4.15.9 Check GNSS Overall Configuration Performance

You might want to check your antenna and GNSS receiver overall performance with the Time-to-First-Fix (TTFF) value.

After a power-down (warm starts, hot starts), the GNSS device triggers a next TTFF value based on antenna setting (or skyview, etc.). See the command line and TTFF value `ttff 329907` in the following example. The unit of `ttff` is nanosecond (smaller number is better).

```
# ubxtool -t -w 3 -p NAV-STATUS -P 29.20
1668999366.1330
UBX-NAV-STATUS:
iTOW 96984000 gpsFix 3 flags 0xdd fixStat 0x0 flags2 0x8
ttff 329907, msss 325236062
```

For more details how to configure the u-Blox ZED-F9T-00B module, refer to:

[https://content.u-blox.com/sites/default/files/ZED-F9T\\_IntegrationManual\\_UBX-21040375.pdf?hash=undefined](https://content.u-blox.com/sites/default/files/ZED-F9T_IntegrationManual_UBX-21040375.pdf?hash=undefined)

**Note:** In some cases, when GNSS loses the antenna reference, the GNSS might output for couple of seconds the 1PPS signal and NMEA messages. To more rapidly disqualify the 1PPS and NMEA messages, increase the filtering of GNSS receiver with **ubxtool** command:

```
# ubxtool -P 29.20 -v 1 -w 1 -z CFG-NAVSPG-OUTFIL_TACC,10,5
```

Or run:

```
#echo -ne
"\xb5\x62\x06\x8a\x0a\x00\x00\x05\x00\x00\xb4\x00\x11\x30\x0a\x00\x9e\x1b"
" > /dev/gnssX
```

## 5.0 Configuration Setup

The E810-XXVDA4T provides two coaxial input-output SMA connectors, two unidirectional U.FL connectors and an optional GNSS input connector, as shown in the following two illustrations.

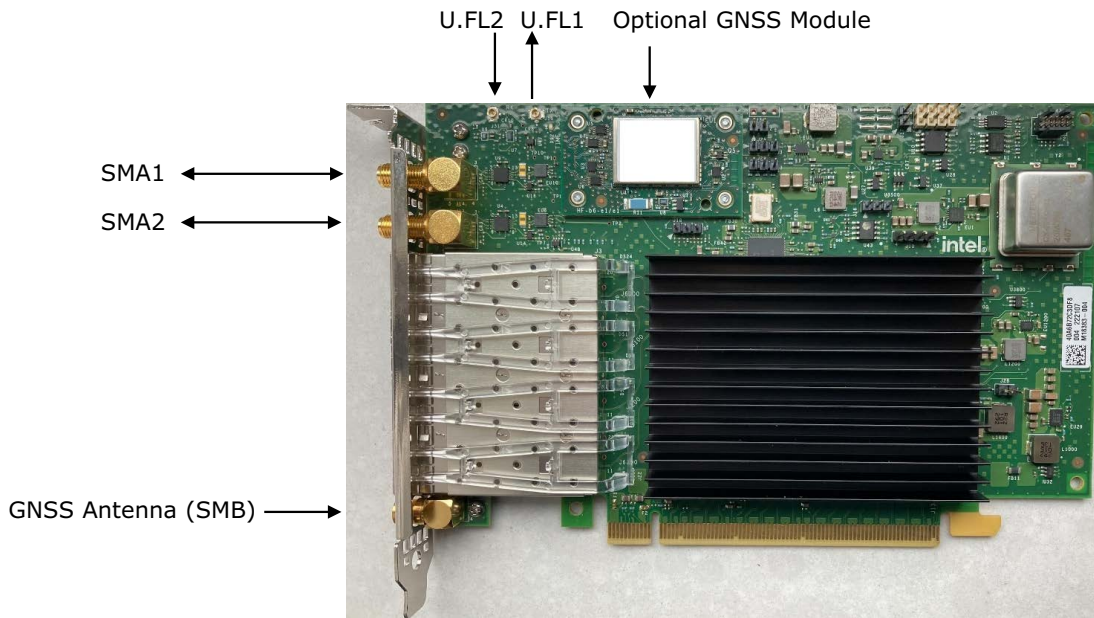

Figure 3. E810-XXVDA4T Connector Locations

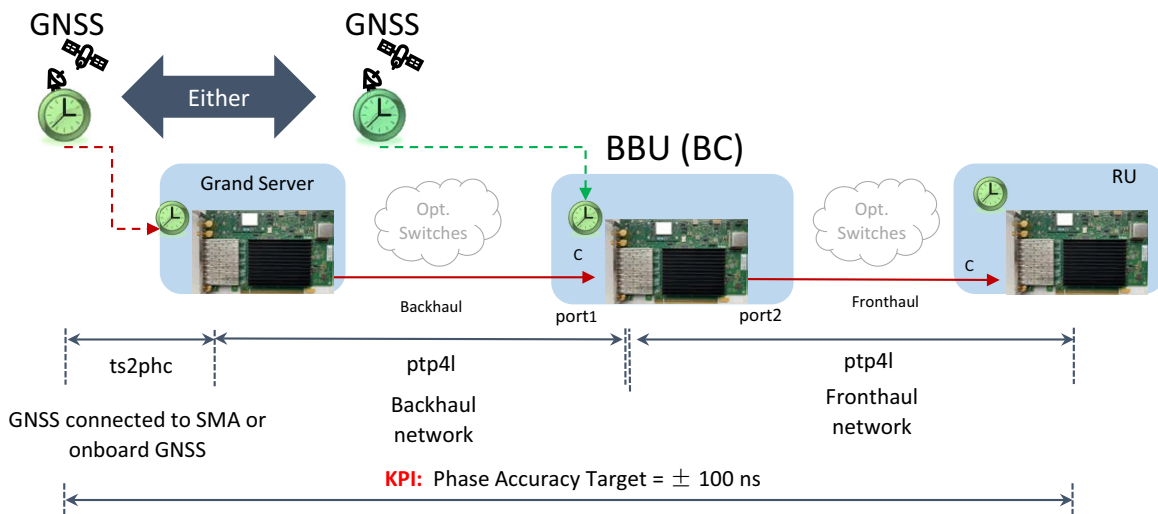

Figure 4. E810-XXVDA4T Connections

## 5.1 Disable All SMA and U.FL Connections

1. Set interface device:

```
# export ETH=`grep 000e /sys/class/net/*/device/subsystem_device | awk -F"/" '{print $5}' | head -n 1`
```

2. Disable U.FL2:

```
# echo 0 2 > /sys/class/net/$ETH/device/ptp/ptp*/pins/U.FL2
```

3. Disable U.FL1:

```
# echo 0 1 > /sys/class/net/$ETH/device/ptp/ptp*/pins/U.FL1
```

4. Disable SMA2:

```
# echo 0 2 > /sys/class/net/$ETH/device/ptp/ptp*/pins/SMA2
```

5. Disable SMA1:

```
# echo 0 1 > /sys/class/net/$ETH/device/ptp/ptp*/pins/SMA1
```

6. All disabled:

```
# echo 0 2 > /sys/class/net/$ETH/device/ptp/ptp*/pins/U.FL2
# echo 0 1 > /sys/class/net/$ETH/device/ptp/ptp*/pins/U.FL1
# echo 0 2 > /sys/class/net/$ETH/device/ptp/ptp*/pins/SMA2
# echo 0 1 > /sys/class/net/$ETH/device/ptp/ptp*/pins/SMA1
```

7. Check with **dmesg**:

```
# dmesg

[793017.697870] ice 0000:84:00.0: SMA1 + U.FL1 disabled
[793017.697871] ice 0000:84:00.0: SMA2 + U.FL2 disabled
```

## 5.2 PTP GrandMaster (GM) with Optional GNSS Module

This configuration is the highest-priority configuration and overrides any other if the GNSS is installed and operational.

### 5.2.1 External Connections

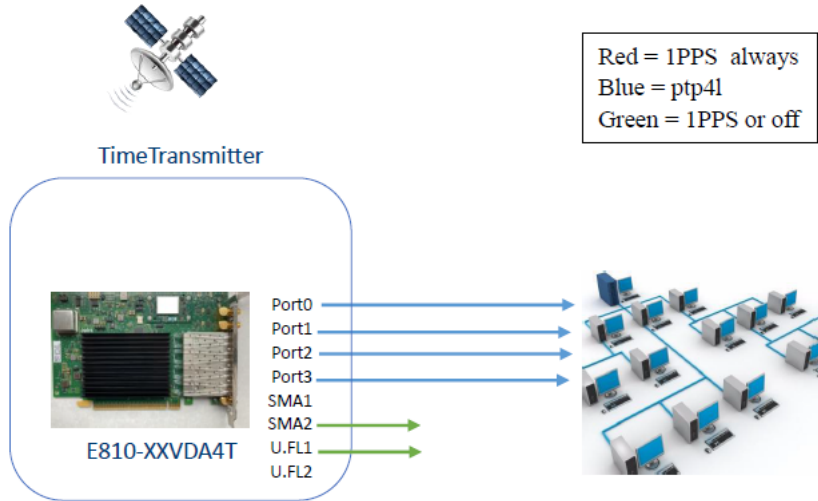

Figure 5. External Connections: PTP GrandMaster with Optional GNSS Module

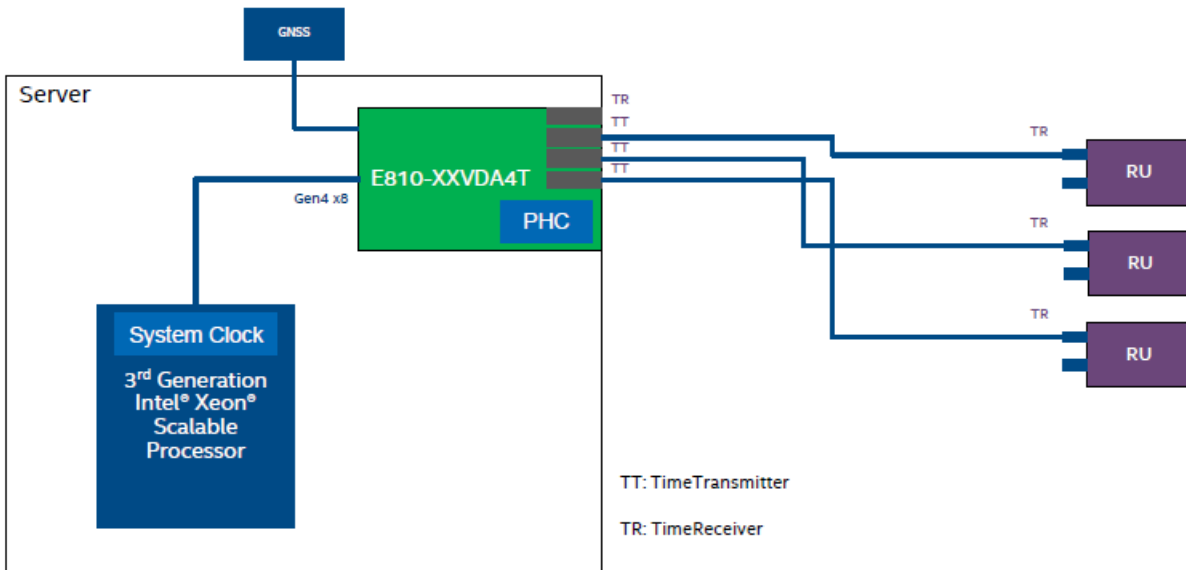
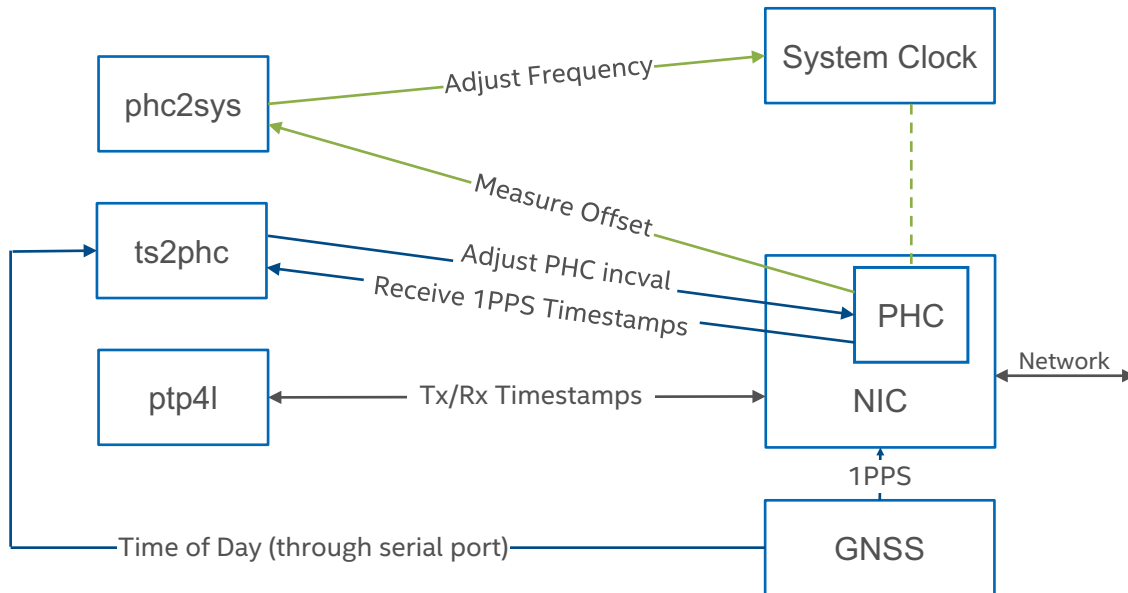

Figure 6. External Connections: Single E810-XXVDA4T Adapter Configuration with GNSS

## 5.2.2 Software Configuration



**Figure 7. Linux Software Stack Overview: Single E810-XXVDA4T Adapter with GNSS Software Stack**

Before proceeding, it is recommended to set all SDP pins and U.FL to off (see [Section 4.0](#)).

1. Set interface device:

```
# export ETH=`grep 000e /sys/class/net/*/device/subsystem_device | awk -F"/" '{print$5}' | head -n 1`
# export PCI_SLOT=`grep PCI_SLOT_NAME /sys/class/net/$ETH/device/uevent | cut -c 15-`
```

2. Make sure GNSS has an active connection: `/dev/gnssX` where `X` stands for the GNSS device number.

```
# cat /dev/gnssX
$GNRMC,182805.00,A,0.0,N,0.0,E,0.082,,050321,,,D,V*14
$GNVTG,,T,,M,0.082,N,0.152,K,D*34
$GNGGA,182805.00,0.0,N,0.0,E,2,12,0.57,11.1,M,32.7,M,,0000*7D
$GNGSA,A,3,18,20,26,23,16,29,07,15,27,10,,,1.07,0.57,0.90,1*09
$GNGSA,A,3,81,79,72,82,80,78,65,88,87,,,1.07,0.57,0.90,2*0C
$GNGSA,A,3,02,30,04,36,11,,,,,,,,,1.07,0.57,0.90,3*0E
```

3. Run `ts2phc`:

```
# ./ts2phc -f configs/ts2phc-generic.cfg -s nmea -m
```

**Note:** You might want filter the 1PPS timestamps till the DPLL locked. See [Section 4.13](#).

**Note:** See [Section 5.8](#), "Example ts2phc Configuration File".

4. Run **phc2sys**:

```
# ./phc2sys -s $ETH -O -37 -m
```

The `-O -37` can be used to accommodate for leap seconds

**Note:** To update **linuxptp** version, use **git clone**:

```
git clone git://git.code.sf.net/p/linuxptp/code
```

To get an appropriate leapfile for RHEL-based Linux distributions:

<https://github.com/eggert/tz/blob/main/leap-seconds.list>

**DO NOT** use `/usr/share/zoneinfo/leapseconds` defined in the `ts2phc.8` file.

5. Run **ptp4l**:

Running on Port 0 (1,2 and 3 as well if required):

```
# ./ptp4l -i $ETH -m
```

6. Run **synce4l** (optional):

```
#./synce4l -f configs/synce4l.cfg -m
```

**Note:** Refer to [Section 5.10](#), "Example synce4l Configuration File for BC".

## 5.3 PTP GrandMaster (GM) with External GNSS Clock

### 5.3.1 External Connections

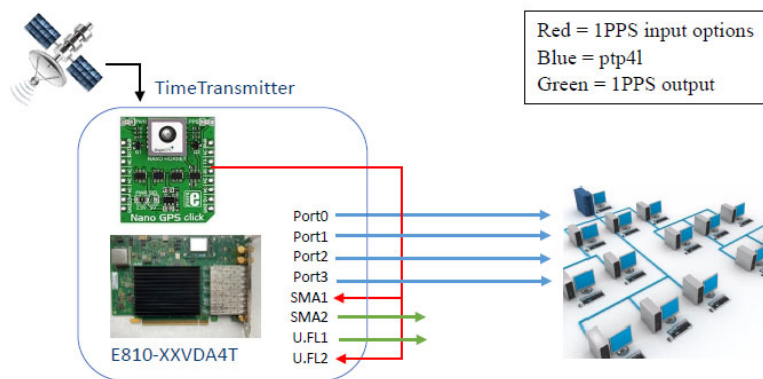

Figure 8. External Connections: PTP GrandMaster with External GNSS Clock

### 5.3.2 Software Configuration

Before proceeding, configure the GNSS to output a 1PPS signal and connect it to SMA1 (or to U.FL2). It is recommended to set all SDP pins and U.FL to off (see [Section 4.0](#)).

1. Set interface device:

```
# export ETH=`grep 000e /sys/class/net/*/device/subsystem_device | awk -F"/" '{print $5}' | head -n 1` # (port0)
# export ETH1=`grep 000e /sys/class/net/*/device/subsystem_device | awk -F"/"'
```

```
{print $5}' | head -n 2 | tail -n +2` #(port1)
# export ETH2=`grep 000e /sys/class/net/*/device/subsystem_device | awk -F"/"
'{print $5}' | head -n 3 | tail -n +3` #(port2)
# export ETH3=`grep 000e /sys/class/net/*/device/subsystem_device | awk -F"/"
'{print $5}' | head -n 4 | tail -n +4` #(port3)
```

## 2. SMA1 as input and SMA2 as output:

```
# echo 1 1 > /sys/class/net/$ETH/device/ptp/ptp*/pins/SMA1
# echo 2 2 > /sys/class/net/$ETH/device/ptp/ptp*/pins/SMA2
```

Or, U.FL2 as input and U.FL1 as output:

```
# echo 1 2 > /sys/class/net/$ETH/device/ptp/ptp*/pins/U.FL2
# echo 2 1 > /sys/class/net/$ETH/device/ptp/ptp*/pins/U.FL1
```

**Note:** If you have SMA1 connected to an external 1PPS source, you cannot use the U.FL configuration.

## 3. Verify that the outputs were set correctly:

```
#dmesg
[793494.341435] ice 0000:84:00.0: SMA1 RX
[793494.341437] ice 0000:84:00.0: SMA2 TX
[793506.667670] ice 0000:84:00.0: <DPLL0> state changed to: unlocked, pin SMA1
[793506.668178] ice 0000:84:00.0: <DPLL1> state changed to: unlocked, pin SMA1
[793518.699755] ice 0000:84:00.0: <DPLL0> state changed to: locked, pin SMA1
[793518.700264] ice 0000:84:00.0: <DPLL1> state changed to: locked, pin SMA1
```

Or:

```
#dmesg
[101056.462309] ice 0000:18:00.0: SMA1 RX + U.FL1 TX
[101056.462317] ice 0000:18:00.0: UFL2 RX
[101090.668497] driver cannot use function 1 on pin 0
```

## 4. Run **ts2phc**:

Running on Port 0:

```
# ./ts2phc -f configs/ts2phc-generic.cfg -s generic -m
```

**Note:** See [Section 5.8, "Example ts2phc Configuration File"](#).

**Note:** You might want filter the 1PPS timestamps till the DPLL locked. See [Section 4.13](#).

## 5. Run **ptp4l**:

Running on Port 0 (1,2 and 3 as well if required):

```
# ./ptp4l -i $ETH -m
```

## 6. Run **synce4l** (optional):

```
#./synce4l -f configs/synce4l.cfg -m
```

**Note:** Refer to [Section 5.10, "Example synce4l Configuration File for BC"](#).



## 5.4 Boundary Clock Configuration

### 5.4.1 External Connections

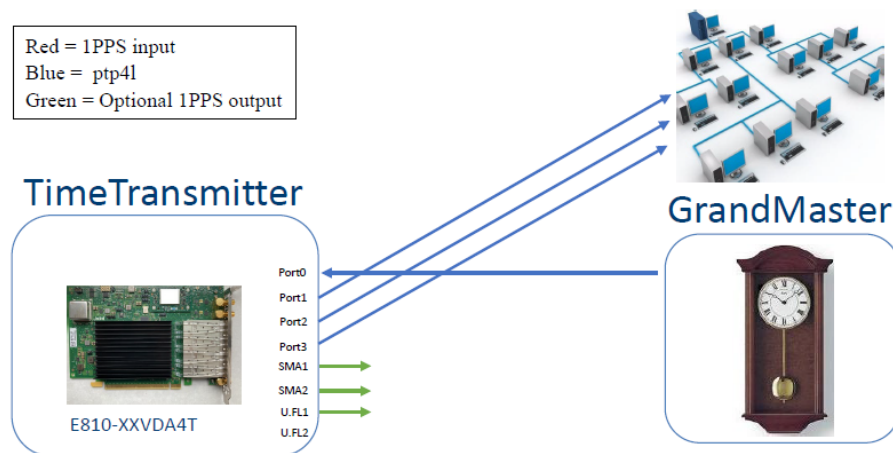

Figure 9. External Connections: Boundary Clock Configuration

### 5.4.2 Boundary Clock Notes

- For visibility, users might want to enable 1PPS on the SMA1.
- If users want to synchronize the DPLL to the E810 PHC, they must enable the appropriate SDP pin, as there are two DPLLs: DPLL0 drives the external clock source of the E810 controller, while DPLL1 drives the SMA outputs.
- If users want to synchronize DPLL1 to **ptp4l**, then they must use SDP20.
- SMA1 Tx and U.FL1 Tx is not a supported configuration on the E810-XXVDA4T.

### 5.4.3 Software Configuration

Before proceeding, it is recommended to set all SDP pins and U.FL to off (see [Section 4.0](#)).

1. Set interface device (only top command is essential):

```
# export ETH=`grep 000e /sys/class/net/*/device/subsystem_device | awk -F"/"
  \{print $5}\` | head -n 1' (port0)
# export ETH1=`grep 000e /sys/class/net/*/device/subsystem_device | awk -F"/"
  \{print $5}\` | head -n 2 | tail -n +2' (port1)
# export ETH2=`grep 000e /sys/class/net/*/device/subsystem_device | awk -F"/"
  \{print $5}\` | head -n 3 | tail -n +3' (port2)
# export ETH3=`grep 000e /sys/class/net/*/device/subsystem_device | awk -F"/"
  \{print $5}\` | head -n 4 | tail -n +4' (port3)
```

2. Set periodic output on SDP20 to 10 MHz (to synchronize the DPLL1 to the E810 PHC synced by **ptp4l**):

```
# echo 1 0 0 0 100 > /sys/class/net/$ETH/device/ptp/ptp*/period
```

and set SDP22 (to synchronize the DPLL1 to the E810 PHC synced by **ptp4l**):

```
# echo 2 0 0 1 0 > /sys/class/net/$ETH/device/ptp/ptp*/period
```

**Note:** DPLL only syncs to SDP20/SDP22 if it is the higher priority. Setting SDP20 is the preferred method for synchronizing 1PPS outputs.

3. Enable SMA1 output (for visibility):

```
# echo 2 1 > /sys/class/net/$ETH/device/ptp/ptp*/pins/SMA1
```

Or:

- Enable U.FL1 output: (for visibility):

```
# echo 2 1 > /sys/class/net/$ETH/device/ptp/ptp*/pins/U.FL1
```

- Enable SMA2 output: (for visibility):

```
# echo 2 2 > /sys/class/net/$ETH/device/ptp/ptp*/pins/SMA2
```

**Note:** If U.FL1 is set to Tx, then SMA1 is also set to Rx and cannot be changed. Make sure no 1PPS input is connected to SMA1 if using U.FL1 as Tx.

4. Verify if the outputs were set correctly:

```
#dmesg
[27526.767803] ice 0000:84:00.0: SMA1 TX
[27526.767804] ice 0000:84:00.0: SMA2 TX
[27526.852127] ice 0000:18:00.0: <DPLL1> state changed to: unlocked, pin CVL-SDP20
[30243.385109] ice 0000:18:00.0: <DPLL1> state changed to: locked, pin CVL-SDP20
```

Or:

```
#dmesg
[27611.114869] ice 0000:84:00.0: SMA1 RX + U.FL1 TX
[27611.114870] ice 0000:84:00.0: SMA2 TX
[27611.824727] ice 0000:18:00.0: <DPLL1> state changed to: unlocked, pin CVL-SDP20
[30243.385109] ice 0000:18:00.0: <DPLL1> state changed to: locked, pin CVL-SDP20
```

5. Run **ptp4l**:

```
# ./ptp4l -i $ETH -i $ETH1 -i $ETH2 -i $ETH3 -m
```

**Note:** For BC, it is recommended to use one **ptp4l** instance.

6. Run **synce4l** (optional):

```
#./synce4l -f configs/synce4l.cfg -m
```

**Note:** Refer to [Section 5.10, "Example synce4l Configuration File for BC"](#).

## 5.5 Port Configured as TimeReceiver

The E810-XXVDA4T has one PHC that is shared across all the ports. As a result, only one PTP follower can be run as shown.

### 5.5.1 External Connections

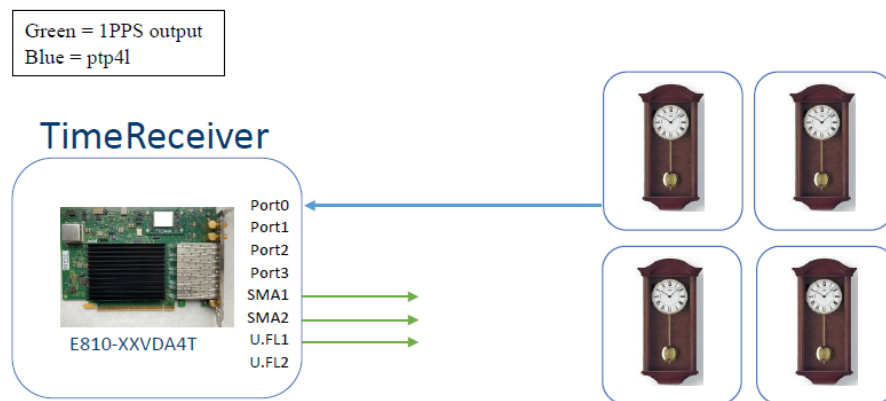

Figure 10. External Connections: Port Configured as TimeReceiver

### 5.5.2 Software Configuration

Before proceeding, it is recommended to set all SDP pins and U.FL to off (see [Section 4.0](#)).

1. Set interface device:

```
# export ETH=`grep 000e /sys/class/net/*/device/subsystem_device | awk -F"/" '{print $5}' | head -n 1`
```

2. Set the periodic output on SDP20 to 10 MHz (to synchronize the DPLL1 to the E810 PHC synced by **ptp4l**):

```
# echo 1 0 0 0 100 > /sys/class/net/$ETH/device/ptp/ptp*/period
```

and set SDP22 (to synchronize the DPLL1 to the E810 PHC synced by **ptp4l**):

```
# echo 2 0 0 1 0 > /sys/class/net/$ETH/device/ptp/ptp*/period
```

**Note:** DPLL only syncs to SDP20/SDP22 if it is the higher priority. Setting SDP20 is the preferred method for synchronizing 1PPS outputs.

3. Enable SMA1 output: (for visibility):

```
# echo 2 1 > /sys/class/net/$ETH/device/ptp/ptp*/pins/SMA1
```

Or:

- Enable U.FL1 output (for visibility):

```
# echo 2 1 > /sys/class/net/$ETH/device/ptp/ptp*/pins/U.FL1
```

- Enable SMA2 output (for visibility):

```
# echo 2 2 > /sys/class/net/$ETH/device/ptp/ptp*/pins/SMA2
```

**Note:** If U.FL1 is set to Tx then SMA1 is also set to Rx and cannot be changed. Make sure no 1PPS input is connected to SMA1 if using U.FL1 as Tx.

4. Verify if the outputs were set correctly:

```
#dmesg
[ 827.397307] ice 0000:18:00.0: SMA1 TX
[ 827.397315] ice 0000:18:00.0: SMA2 + U.FL2 disabled
[ 837.852127] ice 0000:18:00.0: <DPLL1> state changed to: unlocked, pin CVL-SDP20
[1243.385109] ice 0000:18:00.0: <DPLL1> state changed to: locked, pin CVL-SDP20
```

Or:

```
#dmesg
[ 7827.397307] ice 0000:18:00.0: SMA1 RX + U.FL1 TX
[ 7827.397315] ice 0000:18:00.0: SMA2 + U.FL2 disabled
[ 7837.852127] ice 0000:18:00.0: <DPLL1> state changed to: unlocked, pin CVL-SDP22
[10243.385109] ice 0000:18:00.0: <DPLL1> state changed to: locked, pin CVL-SDP22
```

```
#dmesg
[ 827.397307] ice 0000:18:00.0: SMA1 + U.FL1 disabled
[ 827.397315] ice 0000:18:00.0: SMA2 TX
[ 837.852127] ice 0000:18:00.0: <DPLL1> state changed to: unlocked, pin CVL-SDP20
[1243.385109] ice 0000:18:00.0: <DPLL1> state changed to: locked, pin CVL-SDP20
```

**Note:** The first two lines of each *dmesg* changes depending on what outputs are enabled for visibility.

5. Run **ptp4l**:

```
./ptp4l -i $ETH -m -s
```

## 5.6 SyncE Setup

This configuration shows how to specifically setup SyncE. Note that users can use this SyncE configuration with tools such as **ptp4l** together for clock recovery. SyncE ITU G.811 and G.8262 can assist with better frequency synchronization.

There are two main configuration options for SyncE:

- Only physical clock recovery ([Section 5.6.2](#)).
- With ITU G.8264 ESMC messaging using `syncE4l` ([Section 5.6.3](#)).

### 5.6.1 External Connections

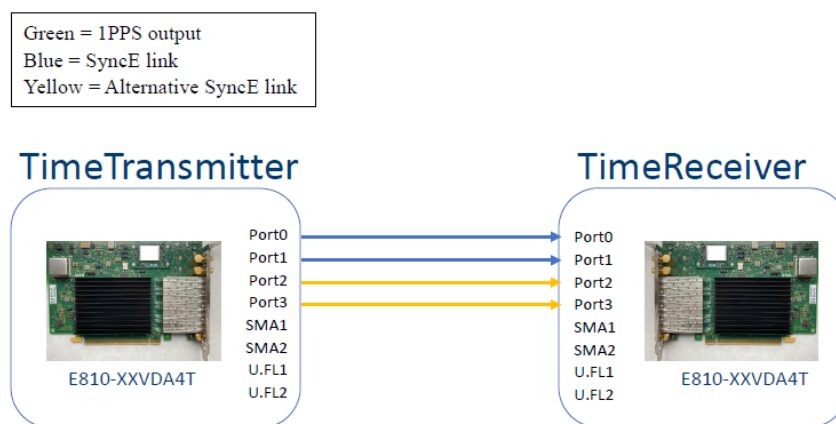

Figure 11. External Connections: SyncE Setup

### 5.6.2 Physical Clock Recovery

Before proceeding, it is recommended to set all SMA and U.FL connectors to off (see [Section 4.0](#)).

1. Set relevant interface device (only top command is essential):

```
# export ETH=`grep 000e /sys/class/net/*/device/subsystem_device | awk -F"/"
  \{print $5}' | head -n 1' (port0)
# export ETH1=`grep 000e /sys/class/net/*/device/subsystem_device | awk -F"/"
  \{print $5}' | head -n 2 | tail -n +2' (port1)
# export ETH2=`grep 000e /sys/class/net/*/device/subsystem_device | awk -F"/"
  \{print $5}' | head -n 3 | tail -n +3' (port2)
# export ETH3=`grep 000e /sys/class/net/*/device/subsystem_device | awk -F"/"
  \{print $5}' | head -n 4 | tail -n +4' (port3)
```

2. To enable recovered clock from port0 on the highest priority clock run:

```
# echo 1 0 > /sys/class/net/$ETH/device/phy/synce
```

3. To enable recovered clock from port1 on the lowest priority clock run:

```
# echo 1 1 > /sys/class/net/$ETH1/device/phy/synce
```

**Note:** First integer represents enable (1) or disable (0), and the second represents the highest clock priority (0) and lowest clock priority (1).

4. Verify if the outputs were set correctly

```
#dmesg
[19707.757036] ice 0000:18:00.1: Enabled recovered clock: pin C827_0-RCLKB
[19718.804404] ice 0000:18:00.0: <DPLL0> state changed to: unlocked, pin C827_0-RCLKB
[19718.804920] ice 0000:18:00.0: <DPLL1> state changed to: unlocked, pin C827_0-RCLKB
[19719.511845] ice 0000:18:00.0: Enabled recovered clock: pin C827_0-RCLKA
[19789.633771] ice 0000:18:00.0: <DPLL0> state changed to: locked, pin C827_0-RCLKA
```

**Note:** Only enable SyncE on one adapter, either TimeTransmitter or TimeReceiver is acceptable. If both are set, users might run into sync loop issues.

### 5.6.3 ITU G.8264 ESMC Messaging Using sync4I

The sync4I application is implementing the G.8264 ESMC protocol.

1. Run **sync4I**:

```
# ./sync4I -f configs/sync4I.cfg -l 7 -m
```

**Note:** Refer to Section 5.10, "Example sync4I Configuration File for BC".

### 5.6.4 Two E810-XXVDA4T Adapter Configuration without GNSS

Figure 12 shows two E810-XXVDA4T adapters in a system with a cell site router.

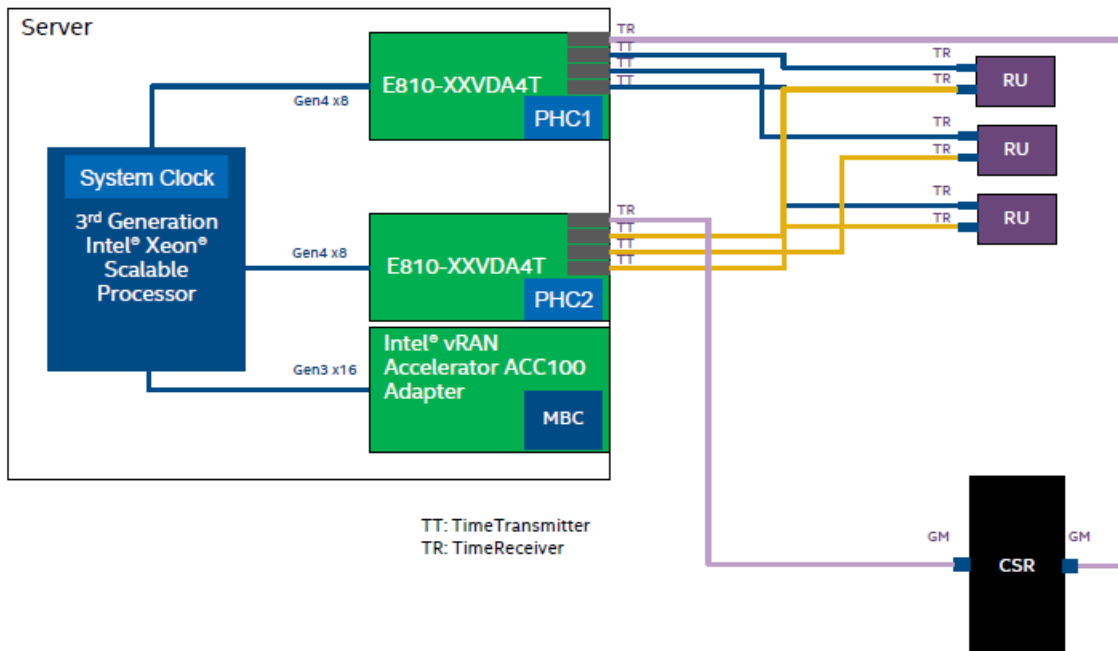
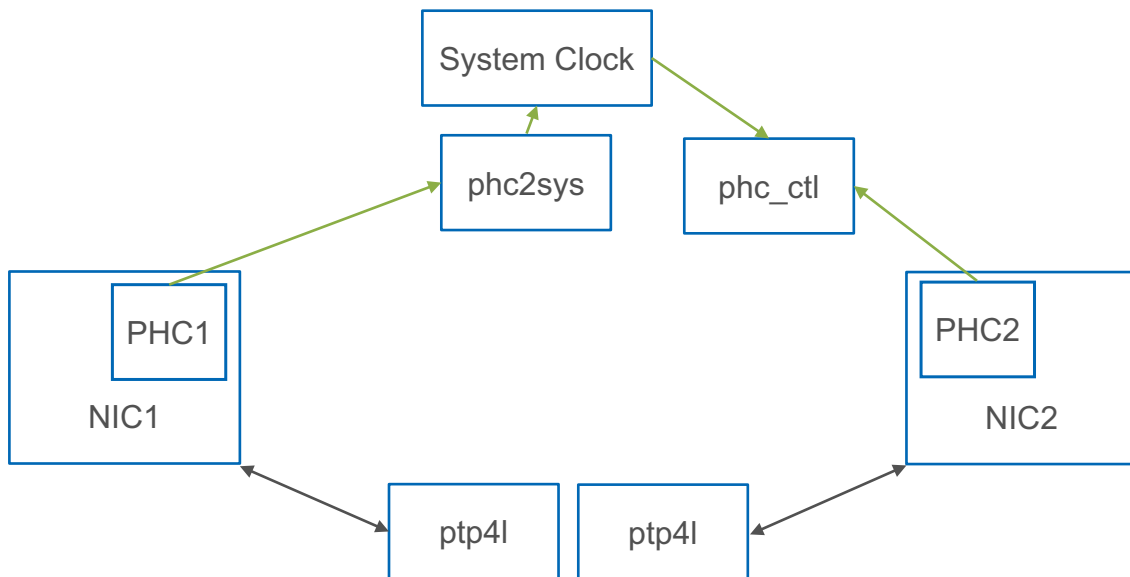
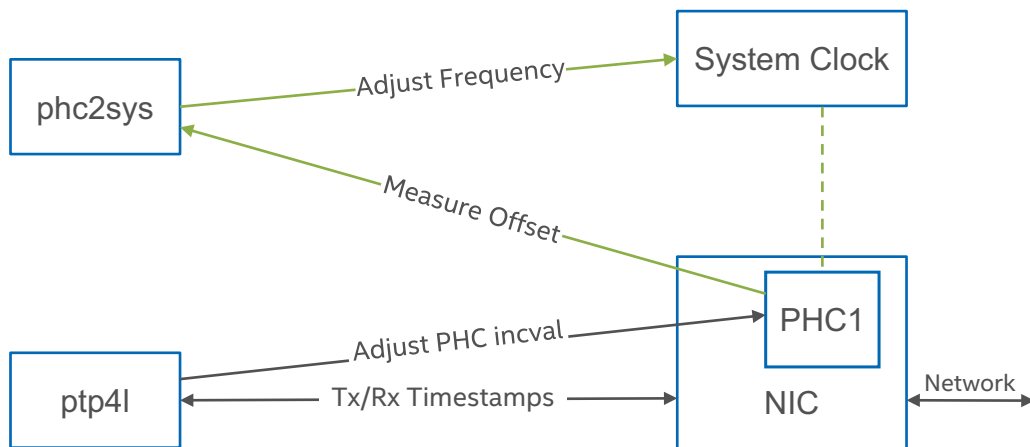

Figure 12. External Connections: Two E810-XXVDA4T Adapters without GNSS



**Figure 13. External Connections: Two E810-XXVDA4T Adapters without GNSS Linux Software Stack**

**Adapter 1 Linux software stack:**



**Figure 14. External Connections: Two E810-XXVDA4T Adapters without GNSS Adapter 1 Software Stack**

**Adapter 1 configuration:**

1. Run one instance of **ptp4l** per E810-XXVDA4T:
 

```
# ptp4l -m -f config.cfg -i ens1f0 -i ens1f1 -i ens1f2 -i ens1f3
```
2. Run **phc2sys** to synchronize system time to the PHC time:
 

```
# phc2sys -s ens1f0 -c CLOCK_REALTIME -w -m
```

**Adapter 2 Linux software stack:**

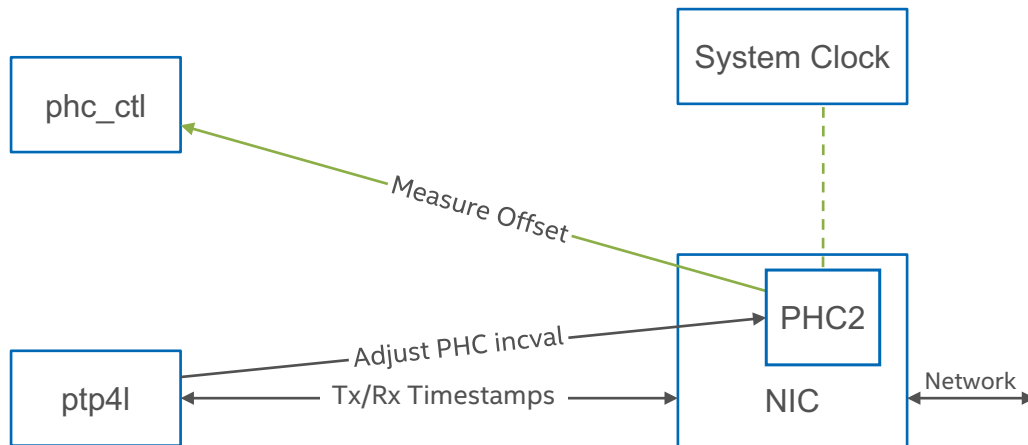

**Figure 15. External Connections: Two E810-XXVDA4T Adapters without GNSS Adapter 2 Software Stack**

**Adapter 2 configuration:**

1. Run one instance of **ptp4l** per E810-XXVDA4T:

```
# ptp4l -m -f config.cfg -i ens2f0 -i ens2f1 -i ens2f2 -i ens2f3
```

2. Monitor PHC time on adapter two vs. system time:

```
# phc_ctl ens2f0 cmp
```



### 5.6.5 Two E810-XXVDA4T Adapter Configuration without GNSS and with 1PPS

Figure 16 shows two E810-XXVDA4T adapters in a system with a 1PPS connection between them.

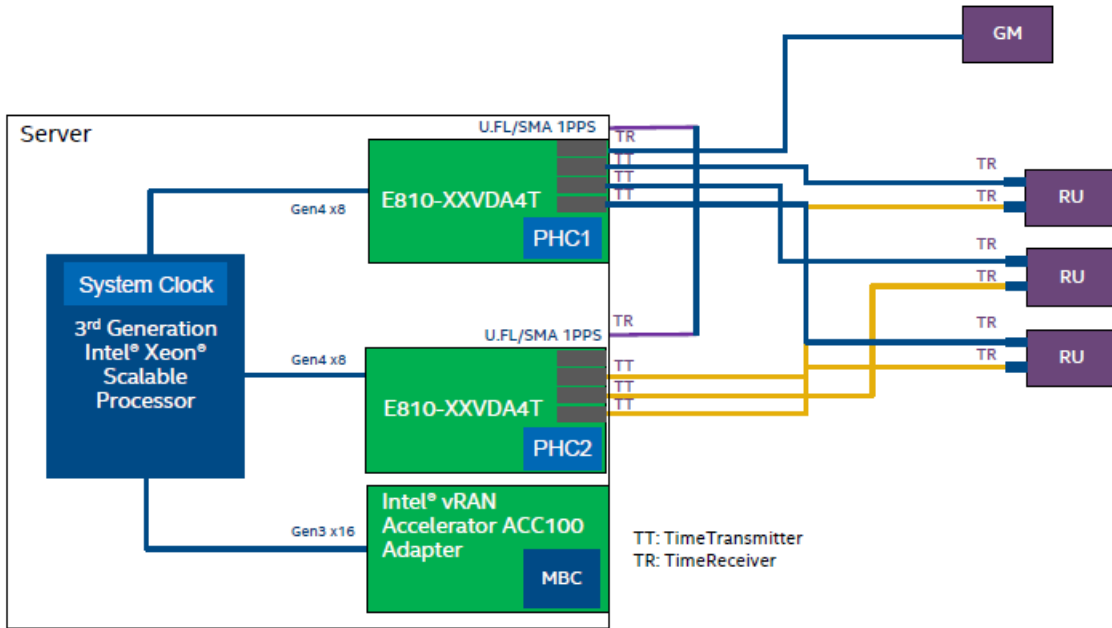

Figure 16. External Connections: Two E810-XXVDA4T Adapter Configuration (no GNSS)

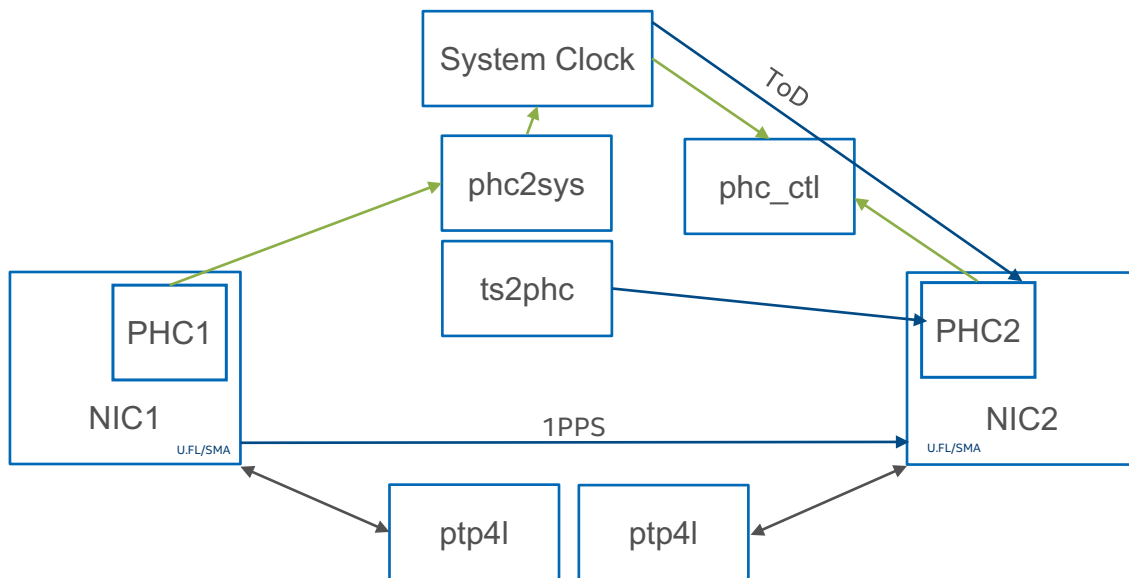
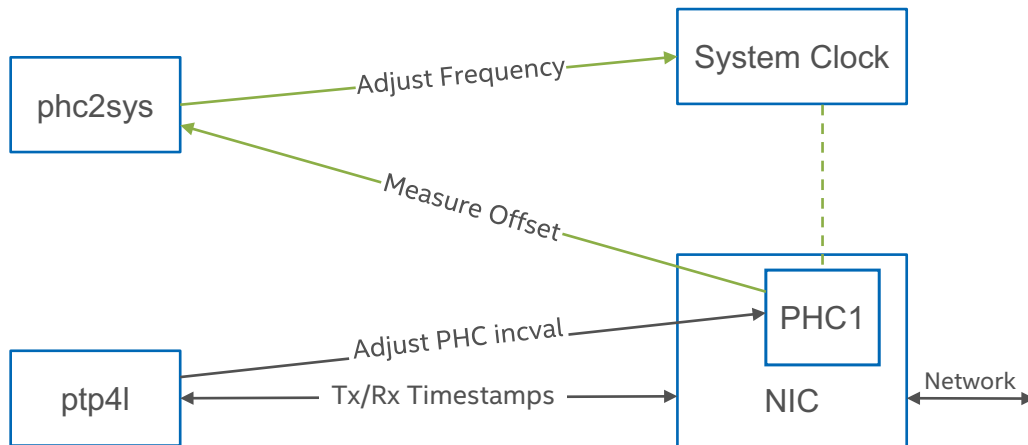

Figure 17. External Connections: Two E810-XXVDA4T Adapter Configuration Linux Software Stack (no GNSS)

**Adapter 1 Linux software stack:**



**Figure 18. Linux Software Stack Overview: Adapter 1 (no GNSS)**

**Adapter 1 configuration:**

1. Enable 1PPS output on U.FL1:

```
# echo 2 1 > /sys/class/net/ens1f0/device/ptp/ptp*/pins/U.FL1
```

or SMA 1:

```
# echo 2 1 > /sys/class/net/$ETH/device/ptp/ptp*/pins/SMA1
```

2. Enable SDP20/SDP22

Set periodic output on SDP20 to 10 MHz (to synchronize the DPPLL1 to the E810 PHC synced by **ptp4l**):

```
# echo 1 0 0 0 100 > /sys/class/net/$ETH/device/ptp/ptp*/period
```

and set SDP22 (to synchronize the DPPLL1 to E810 PHC synced by **ptp4l**):

```
# echo 2 0 0 1 0 > /sys/class/net/$ETH/device/ptp/ptp*/period
```

3. Run **ptp4l**:

```
# ptp4l -m -f config.cfg -i ens1f0 -i ens1f1 -i ens1f2 -i ens1f3
```

4. Run **phc2sys** to synchronize system time to the PHC time:

```
# phc2sys -c ens1f0 -s CLOCK_REALTIME -w -m
```

### Adapter 2 Linux software stack:

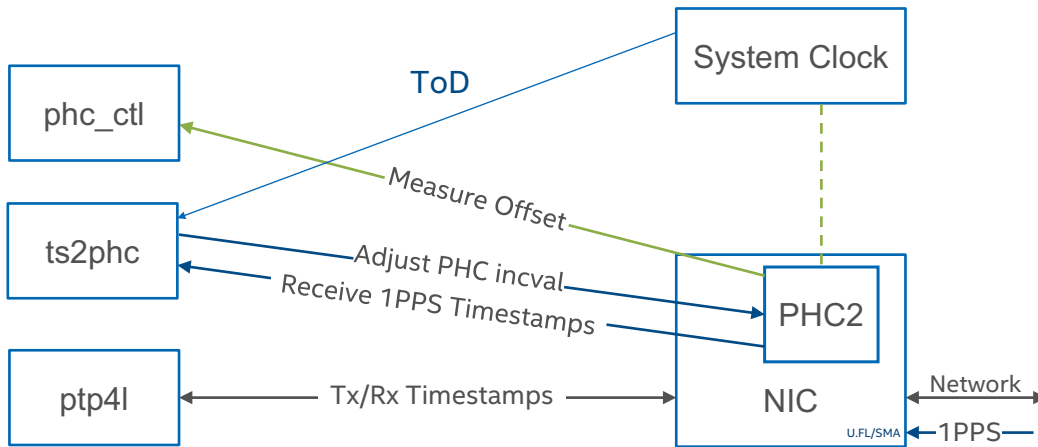

Figure 19. Linux Software Stack Overview: Adapter 2 (no GNSS)

### Adapter 2 configuration:

1. Enable 1PPS input on U.FL2:

```
# echo 1 2 > /sys/class/net/ens2f0/device/ptp/ptp*/pins/U.FL2
```

or, enable 1PPS input on SMA2:

```
# echo 1 2 > /sys/class/net/$ETH/device/ptp/ptp*/pins/SMA2
```

2. Run **ts2phc** to get time from 1PPS over U.FL2 and ToD from system:

```
# ts2phc -f config.cfg -s generic -c ens2f0
```

3. Run **ptp4l**:

```
# ptp4l -m -f config.cfg -i ens2f0 -i ens2f1 -i ens2f2 -i ens2f3
```

4. Monitor PHC time on adapter 2 comparing to system time:

```
# phc_ctl ens2f0 cmp
```

### Notes:

- Only enable SDP20/SDP22 1PPS when PTP or SyncE is actively synced.
- Monitor/switch **phc2sys**, if one adapter loses sync in multi-adapter system.
- Use a different UDS socket when running multiple **ptp4l** instances.

### 5.6.6 Two E810-XXVDA4T Adapters with GNSS Connection Setup

Figure 20 shows two E810-XXVDA4T adapters in a system with a GNSS connection.

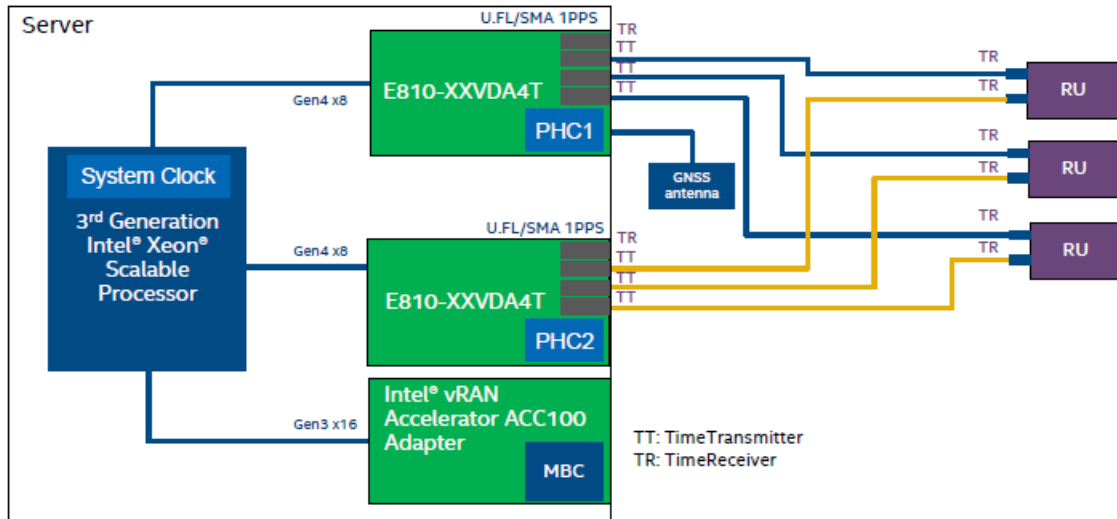

Figure 20. External Connections: Two E810-XXVDA4T Adapter Configuration (with GNSS)

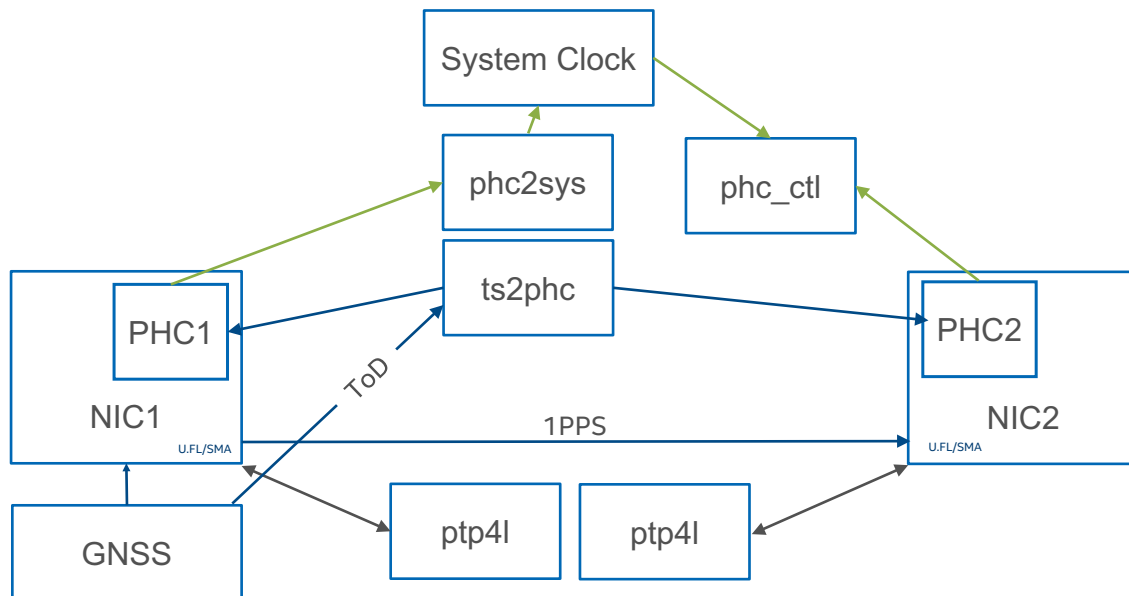
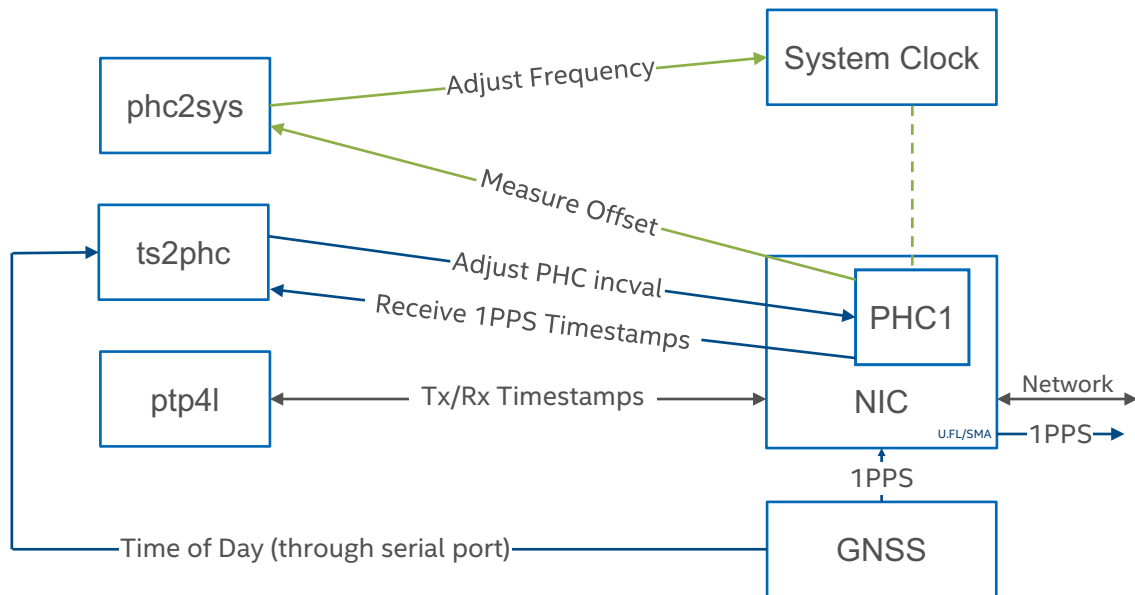

Figure 21. External Connections: Two E810-XXVDA4T Adapter Configuration Linux Software Stack (with GNSS)

### Adapter 1 Linux software stack:



**Figure 22. Linux Software Stack Overview: Adapter 1 (with GNSS)**

### Adapter 1 configuration:

1. Run **ts2phc** to get time from the GNSS:

```
# ts2phc -f config.cfg -s nmea -c ens1f0
```

You can also use NMEA to get time to both adapters:

```
# ts2phc -f config.cfg -s nmea -c ens1f0 -c ens2f0
```

2. Enable 1PPS out on U.FL1:

```
# echo 2 1 > /sys/class/net/ens1f0/device/ptp/ptp*/pins/U.FL1
```

3. Run **ptp4l**:

```
# ptp4l -m -f config.cfg -i ens1f0 -i ens1f1 -i ens1f2 -i ens1f3
```

4. Run **phc2sys** to synchronize system time to the PHC time:

```
# phc2sys -s ens1f0 -c CLOCK_REALTIME -w -m
```

**Adapter 2 Linux software stack:**

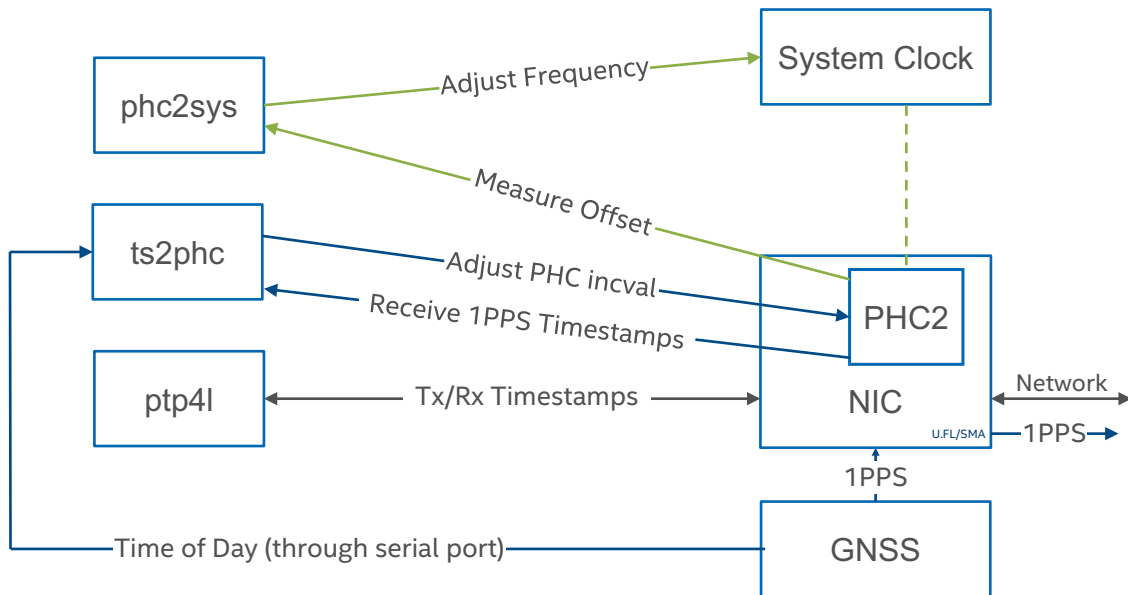

**Figure 23. Linux Software Stack Overview: Adapter 2 (with GNSS)**

**Adapter 2 configuration:**

1. Enable 1PPS in on U.FL2:
 

```
# echo 1 2 > /sys/class/net/ens2f0/device/ptp/ptp*/pins/U.FL2
```
2. Run **ts2phc** to get time from 1PPS over U.FL2 and ToD from system:
 

```
# ts2phc -f config.cfg -s generic -c ens2f0
```
3. Run **ptp4l**:
 

```
# ptp4l -m -f config.cfg -i ens2f0 -i ens2f1 -i ens2f2 -i ens2f3
```
4. Monitor PHC time on adapter 2 comparing to system time:
 

```
# phc_ctl ens2f0 cmp
```

## 5.7 O-RAN Configuration 1

### 5.7.1 External Connections

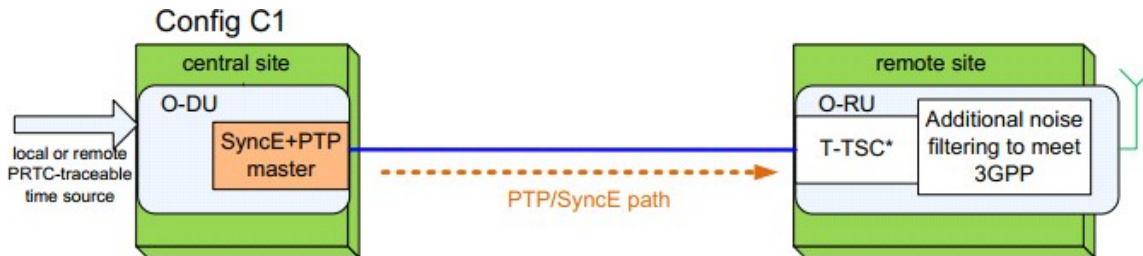

Figure 24. External Connections: O-RAN Configuration 1

**Note:** O-RAN Fronthaul Working Group Control, User and Synchronization Plane Specification, 2020.

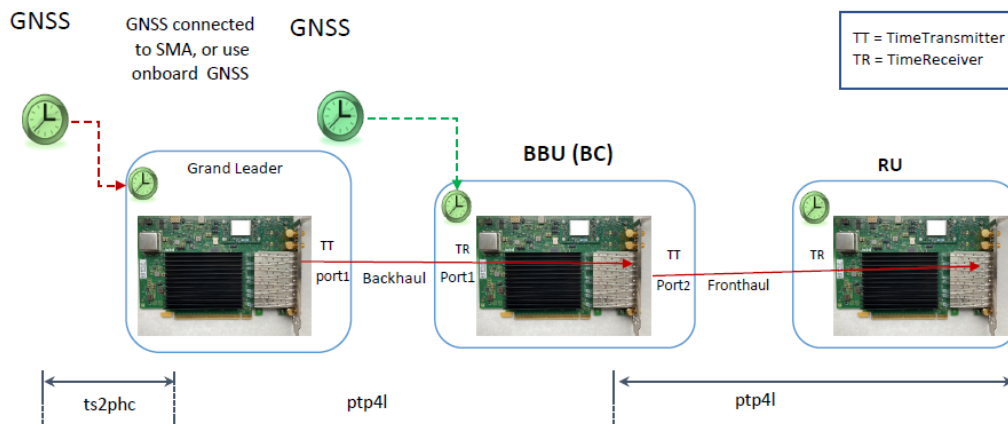

Figure 25. O-RAN Configuration 1 Connections

### 5.7.2 Software Configuration

- GrandMaster adapter (see [Section 5.2](#) and [Section 5.3](#))
- BBU (BC) Adapter (see [Section 5.4](#))
- RU Adapter (see [Section 5.5](#))

## 5.8 Example ts2phc Configuration File

```
[global]
use_syslog          0
verbose            1
logging_level      7
ts2phc.pulsewidth  100000000
# For GNSS module
ts2phc.nmea_serialport /dev/gnss0 #/dev/gnssX, where X is GNSS device number.
leapfile            /home/<USER>/linuxptp-4/leapseconds.list
[enpls0f0(dev/ptp4)]
ts2phc.extts_polarity rising
```

**Note:** The **leapfile** option is available but not necessary for the program to run.

## 5.9 Example ptp4l Configuration File for BC

```
[global]
#
# Default Data Set
#
twoStepFlag        1
clientOnly         0
priority1          129
priority2          255 #lower value = higher priority to become TimeTransmitter
domainNumber       24
utc_offset         37
clockClass         255
clockAccuracy      0xFE
offsetScaledLogVariance 0xFFFF
free_running       0
freq_est_interval  1
dataset_comparison G.8275.x
G.8275.portDS.localPriority 128

#
# Port Data Set
#
logAnnounceInterval -3
logSyncInterval     -4
logMinDelayReqInterval -4
logMinPdelayReqInterval 0
announceReceiptTimeout 3
syncReceiptTimeout  3
delayAsymmetry      0
fault_reset_interval 4
neighborPropDelayThresh 800
min_neighbor_prop_delay -20000000

#
# Run time options
#
assume_two_step     0
logging_level       6
path_trace_enabled  1
follow_up_info      0
```



```
hybrid_e2e          0
net_sync_monitor    0
tx_timestamp_timeout 10
use_syslog          1
verbose            0
summary_interval    -4
kernel_leap        1
check_fup_sync      0
#
# Servo options
#
pi_proportional_const 0.60
pi_integral_const     0.001
pi_proportional_scale 0.0
pi_proportional_exponent -0.3
pi_proportional_norm_max 0.7
pi_integral_scale     0.0
pi_integral_exponent 0.4
pi_integral_norm_max  0.3
step_threshold        0.00002
first_step_threshold  0.00002
#first_step_threshold 0.0
max_frequency          900000000
clock_servo            pi
sanity_freq_limit     200000000
#freq_est_interval    0
ntpshm_segment        0
#
# Transport options
#
transportSpecific     0x0
#ptp_dst_mac          01:80:C2:00:00:0E
p2p_dst_mac           01:80:C2:00:00:0E
uds_address           /var/run/ptp4l
ptp_dst_mac           01:1B:19:00:00:00
#p2p_dst_mac          01:1B:19:00:00:00

#
# Default interface options
#
network_transport     L2
delay_mechanism        e2e
time_stamping         hardware
tsproc_mode           raw
delay_filter           moving_median
delay_filter_length    10
#tsproc_mode          filter
#delay_filter          moving_average
#delay_filter_length   200
egressLatency         0
ingressLatency        0
```

**Note:** For One-step TimeReceiver mode, please configure twoStepFlag "1" (enabled) and assume\_two\_step "0" disabled. The One-step operation in TimeTransmitter mode is not supported.

## 5.10 Example synce4l Configuration File for BC

```

# Global section is for debugging mostly
[global]
#
# Runtime options
#
logging_level      7
use_syslog         0
verbose           1
message_tag        [synce4l]
smc_socket_path    /tmp/synce4l_socket

#
# Device section
# Per-device configuration
#
# User defined name of a one logical device configured for SyncE in the system.
#
# Clock sources for synchronization can be either external clock sources on
# the device or inputs recovered from the PHY's.
# The QL of the external clock sources is configured in the external sources
# sections [{<clk src name>}], under the device.
# The ports configured (in the port-sections [<dev name>], under the device
# section) will be monitored for the QL (Quality Level).
# QL is sent by the peer connected to the port and represents the Holdover
# performance of the peer.
#
# If QL of external source clock is the best QL in the system, it shall be used
# to feed its frequency to all ports.
# If QL of clock recovered from port is the best QL in the system, its frequency
# recovered on that port shall be used to feed its frequency to all the other ports.
#
# All the external clock sources and ports configured after this section will
# be a part of this device (until next device section).
[<syncel>]

#
# If extended TLV shall be supported on the device.
# 0 if no extended tlv shall be supported
# 1 if extended tlv shall be supported
# default: 0
#
# In case of 0:
#     - the port will always TX the non-extended TLV, for RX only
#     non-extended TLV will be processed for reference signal selection
# In case of 1:
#     - The TX version of TLV will be propagated from the port or external
#     clock source that was chosen as candidate for frequency synchronization
#
extended_tlv        1

#
# Which network option shall be supported
#

```

```
# 1 or 2 as defined in T-REC-G.8264
# default: 1
#
# This is rather per-network option, all device in SyncE network
# shall have this configured for the same value
#
network_option          1

#
# Seconds indicating minimum time to recover from the QL-failed state on the
# port.
# Range: 10-720
# Default: 300
#
# If valid QL was not received from one of the source ports within 5 seconds
# the port is no longer a valid source (marked as QL-failed)
#
# Valid QL must be received for more then "recover_time" seconds on that port
# to use its PHY recovered signal again as a valid source
#
recover_time            10

#
# Shell command to be executed in order to obtain current EEC status of a
# device.
#
eec_get_state_cmd       cat /sys/class/net/ens785f0np0/device/dpll_0_state

#
# EEC state values, must equal to values produced by stdout of
# "eec_get_state_cmd" command
#
eec_holdover_value      4
eec_locked_ho_value     3
eec_locked_value        2
eec_freerun_value       1
eec_invalid_value       0

#
# Port section(s)
#
# It starts per-port configuration.
# Each port (of the device) that is used for SyncE, shall have its own section.
#
[ens785f0np0]

#
# msec resolution of TX the QL from this port to the peer
# [100-3000], default:1000 (1000 = 1 second is expected by the standard)
#
# As the standard expects 1 sec, it is not recommended to use different
# than a 1000.
#
tx_heartbeat_msec       1000
```

```

#
# recovered PHY signal can be lost at anytime, this is msec resolution of
# reading the socket, acting on signal lost shall be done just after
# [10-500], default:50
#
rx_heartbeat_msec          500

#
# Shell commands for enabling/disabling this port as main recovered clock on a
# device.
#
recover_clock_enable_cmd   echo 1 0 > /sys/class/net/ens785f0np0/device/phy/synce
recover_clock_disable_cmd  echo 0 0 > /sys/class/net/ens785f0np0/device/phy/synce

#
# next configured interface for the device
#
[ens785f1np1]
tx_heartbeat_msec         1000
rx_heartbeat_msec         500
recover_clock_enable_cmd  echo 1 0 > /sys/class/net/ens785f1np1/device/phy/synce
recover_clock_disable_cmd echo 0 0 > /sys/class/net/ens785f1np1/device/phy/synce
[ens785f3np3]
tx_heartbeat_msec         1000
rx_heartbeat_msec         500
recover_clock_enable_cmd  echo 1 0 > /sys/class/net/ens785f3np3/device/phy/synce
recover_clock_disable_cmd echo 0 0 > /sys/class/net/ens785f3np3/device/phy/synce
#
# External source section(s)
#
# It starts per-external clock source configuration.
# External clock sources are either 1PPS from built-in GPS module or 1PPS
# from the on-board SMA connectors.
# Each port (of the device) that is used for SyncE, shall have its own section.
#
#[{SMA1}]

# These values are sent to the peers on configured ports when this source clock
# selected as best clock source.
# Valid values are defined in Table 11-7 and Table 11-8 of recommendation
# ITU-T G.8264.
# They shall be configured appropriately so they are understood by the peer.
#
# input_QL corresponds to the SSM code column.
#
# input_ext_QL corresponds to the Enhanced SSM code column
# (is used only if "extended_tlv = 1"). For example, for QL of 0x02,
# corresponding values of external QL will be 0x20, 0x21, and 0xFF.
#
#input_QL          0x2
#input_ext_QL      0xFF

#
# Shell commands for enabling/disabling this external clock source on a device

```

```
#
#external_enable_cmd    echo 2 1 > /sys/class/net/ens785f3np3/device/ptp/ptp*/pins/
SMA1
#external_disable_cmd  echo 0 1 > /sys/class/net/ens785f3np3/device/ptp/ptp*/pins/
SMA1

#
# An internal source priority, higher priority (lower value) is used to select
# a source as better quality in case two sources are considered equal quality
# [0-255], default:128
#
#internal_prio 0

#
# next configured external clock source for the device
#
#[{SMA2}]
#input_QL              0x2
#input_ext_QL          0xFF
#external_enable_cmd   echo 2 2 > /sys/class/net/ens785f3np3/device/ptp/ptp*/pins/
SMA2
#external_disable_cmd  echo 0 2 > /sys/class/net/ens785f3np3/device/ptp/ptp*/pins/
SMA2
#[{GNSS}]
#input_QL              0x2
#input_ext_QL          0xFF
#internal_prio 255
#external_enable_cmd   echo ""
#external_disable_cmd  echo ""
##
#####
#
# next SyncE device section
#
#[<sync2>]

#
# new port belonging to the "new" device
#
#[enp7s0f0]
```

## 6.0 Initial Test Setup

Two E810-XXVDA4T adapters on two systems with a Trimble GM200 used as a timeserver.

### 6.1 Test Diagram

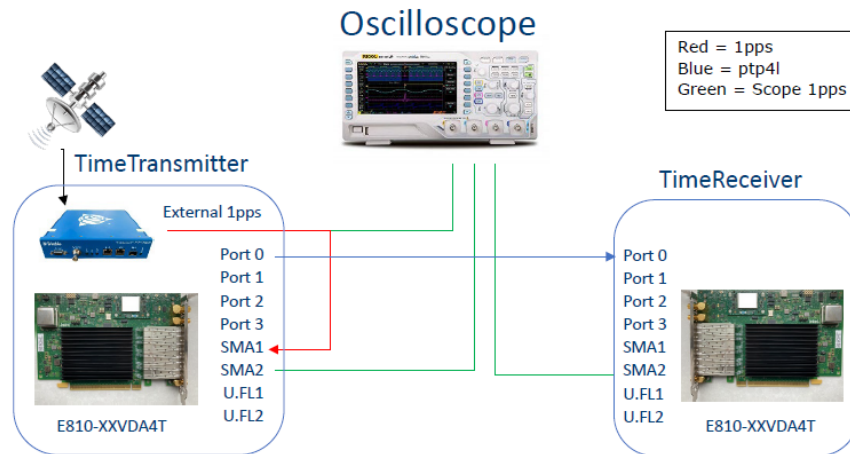

Figure 26. Test Setup

## 6.2 Software Configuration

**Note:** Before proceeding, configure a 1PPS signal on the GrandMaster output.

### 6.2.1 TimeTransmitter Adapter

Before proceeding, configure the GNSS to the output 1PPS signal and connect it to the SMA1 connector (or to U.FL2). Set all SMA and U.FL connectors to off (see [Section 4.0](#)).

1. Set interface device:

```
# export ETH=`grep 000e /sys/class/net/*/device/subsystem_device | awk -F"/" '{print $5}' | head -n 1`
```

2. SMA1 as input and SMA2 as output:

```
# echo 1 1 > /sys/class/net/$ETH/device/ptp/ptp*/pins/SMA1
# echo 2 2 > /sys/class/net/$ETH/device/ptp/ptp*/pins/SMA2
```

**Note:** As a side effect of having a very accurate DPLL, synchronization between the two E810-XXVDA4T adapters can take up to several hours to change to a locked state.

3. Run **ts2phc**:

Running on Port 0:

```
# ./ts2phc -f configs/ts2phc-generic.cfg -s generic -m
```

4. Run **ptp4l**:

```
# ifconfig $ETH 192.168.2.1
```

```
# ./ptp4l -i $ETH -m
```

5. Run **synce4l** (optional):

```
#./synce4l -f configs/synce4l.cfg -m
```

**Note:** Refer to [Section 5.10, “Example synce4l Configuration File for BC”](#).

**Note:** As the default DPLL priority for 1PPS from the SMA is higher than the recover clock's priority.

## 6.2.2 TimeReceiver Adapter

Before proceeding, configure the GNSS to the output 1PPS signal and connect it to the SMA1 connector (or to U.FL2). Set all SMA and U.FL connectors to off (see [Section 4.0](#)).

1. Set interface device:

```
# export ETH=`grep 000e /sys/class/net/*/device/subsystem_device | awk -F"/" '{print $5}' | head -n 1`
```

2. SMA2 as output:

```
# echo 2 2 > /sys/class/net/$ETH/device/ptp/ptp*/pins/SMA2
```

3. Set periodic output on SDP20 and SDP22 (To synchronize the DPLL1 to the E810 PHC synced by **ptp4l**):

```
# echo 1 0 0 0 100 > /sys/class/net/$ETH/device/ptp/ptp*/period  
# echo 2 0 0 1 0 > /sys/class/net/$ETH/device/ptp/ptp*/period
```

**Note:** As a side effect of having a very accurate DPLL, synchronization between the two E810-XXVDA4T adapters can take up to several hours to change to a locked state.

4. Run **ptp4l**:

```
# ifconfig <network_interface_port0> 192.168.2.2  
# ./ptp4l -i <network_interface_port0> -m -s
```

5. Run **synce4l** (optional):

```
#./synce4l -f configs/synce4l.cfg -m
```

**Note:** Refer to [Section 5.10, “Example synce4l Configuration File for BC”](#).

**Note:** As the default DPLL priority for 1PPS from the SMA is higher than the recover clock's priority.

### 6.2.3 Test Results

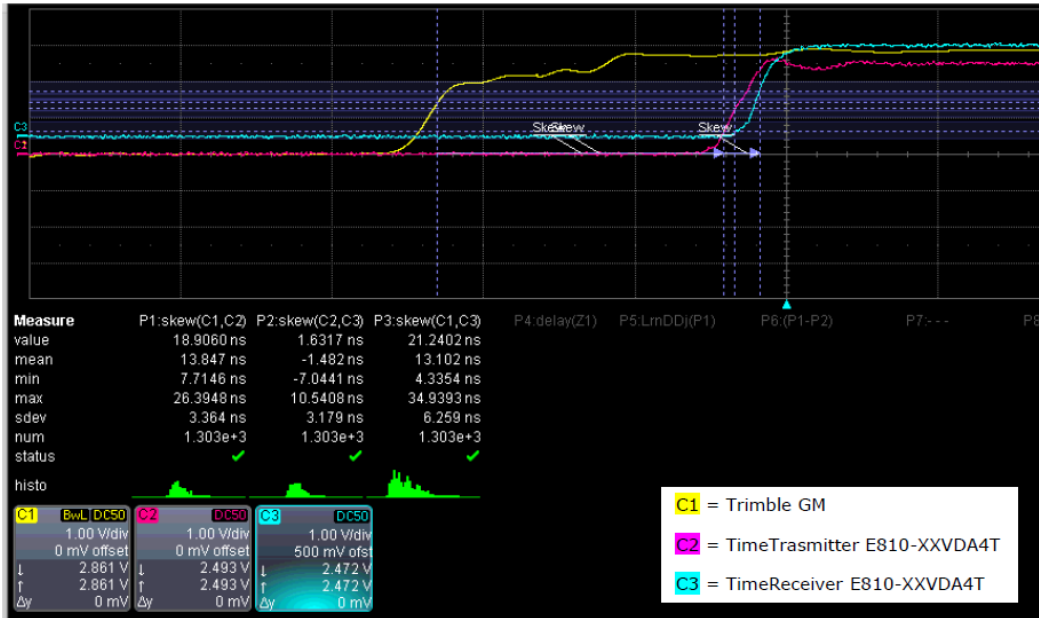

Figure 27. Test Results



## Appendix A Debug Notes

- If you cannot find the SMA or ptpX files, you should check that:
  - You have the latest NVM.
  - You have the latest driver.
  - You ran `make install`.
  - Your kernel support **sysfs** interface (<https://www.kernel.org/doc/html/latest/driver-api/pps.html>). Otherwise, you should update your kernel to a newer one.
- It can take a couple of hours to synchronize the phase while the frequency is already locked. The DPLL status shows unlocked until both the frequency and phase are synchronized.
- When doing measurement, users need to take into consideration together the cable length that is connected the system, scope, and GM.
- Users also need to check equipment precision as some GMs can have >15 ns accuracy.
- If using newer Linux versions, use **systemd**, which has NTP and as a result sysclock based on NTP when using **phc2sys** commands to turn it off/on.

```
# timedatectl set-ntp true(false)
$ timedatectl status
          Local time: Thu 2015-07-09 18:21:33 CEST
          Universal time: Thu 2015-07-09 16:21:33 UTC
             RTC time: Thu 2015-07-09 16:21:33
             Time zone: Europe/Amsterdam (CEST, +0200)
System clock synchronized: yes
              NTP service: (in)active
             RTC in local TZ: no
```

<https://wiki.archlinux.org/index.php/systemd-timesyncd>

- If users run into a “clock frequency higher than an expected” **ptp4l** error, they might be running **ptp4l** as TimeReceiver and TimeTransmitter on the wrong system.
- If **ts2phc** shows SKIPS, it is likely that the extts polarity is set wrong in the *ts2phc* config file.
- If **ts2phc** reports:

```
# ts2phc[4980.802]: enp138s0f0 ignoring invalid master time stamp
```

The problem is that the system time and the GNSS time is too far away and the system time needs to be updated. Set initial system time via one-time update via NTP (using NIST server as an example):

```
ntpd -g -q -x 132.163.97.5
```

- If *tx\_timestamp* does not arrive within the specified time, **linuxptp** completely restarts synchronization. Try increasing *Tx\_timestamping\_timeout* to a larger number, like 10 or 100, but this depends entirely on hardware.

<https://manpages.debian.org/unstable/linuxptp/ptp4l.8.en.html>

- Linux kernels going to sleep, edit:

```
/etc/default/grub GRUB_CMDLINE_LINUX_DEFAULT="quiet splash nohz=off" "sudo update-grub"
```

then restart.

- To check the GNSS receiver performance you might want to use **u-blox U-center** tool. To enable access, you can use the **Netcat** tool that listens on port 2948 for active connection from the U-center:

```
# nc -nvlp 2948 > /dev/gnssX < /dev/gnssX
```

Connecting through TCP in the U-center software:

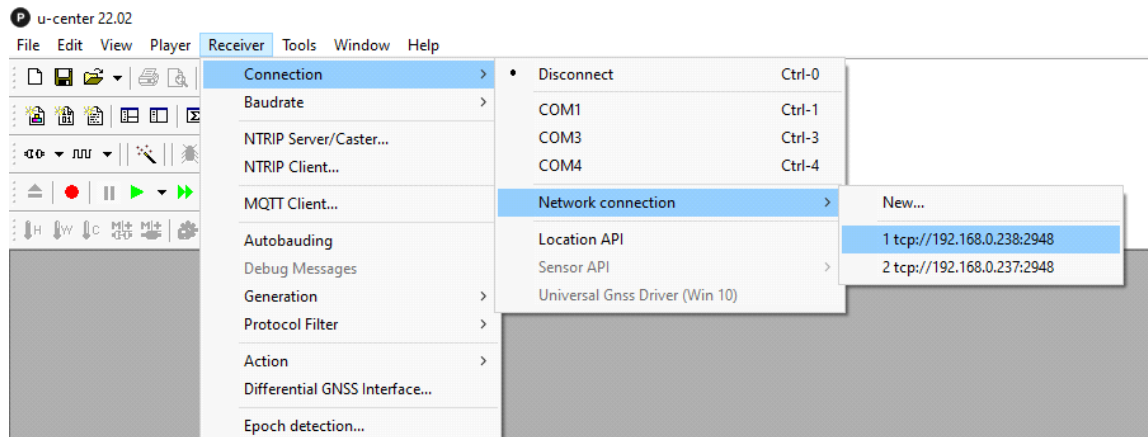

- If you receive the following using **ts2phc** with GNSS module:

```
nmea: unable to find utc time in leap second table

ts2phc[1539626.441]: ens785f0 extts index 0 at 1623669837.999999264 corr 0 src
1623669801.870596298 diff 36999999264

ts2phc[1539626.441]: ens785f0 ignoring invalid master time stamp
```

then you might be using **linuxptp**, Version 3.1, which is incompatible or your pts number in the config file is wrong. Also make sure you have an appropriate leap second file defined in the `.cfg` file (see [Section 5.8](#)).

- If you are experiencing problems where **ethtool -T** does not show Hardware Tx or Rx, you might need to reinsert the Intel `ice` driver with `make install` to include the DPK.
- Some improperly formatted messages, or tools can also “break” the functionality of GNSS module, making it impossible to send configuration changes to GNSS module. Some of these issues can be resolved by restarting the `ice` driver with the following command:

```
# rmmmod ice; modprobe ice
```

- If for some reason you do not want to install **gpsd** on the system, Linux **echo** commands can be used. You must know the hex string sent by **ubxtool** beforehand, send the **echo** command in this format:

```
# echo -ne "<hex_string>" > /dev/gnssX
```

Example - run:

```
# echo -ne "\xb5\x62\x06\x8a\x09\x00\x00\x02\x00\x00\x05\x00\x52\x10\x00\x02\x68"
> /dev/gnssX
```

- Intel recommends disabling UART1 and UART2 interfaces on the GNSS receiver. To do that, use:

1. Disable UART1 in RAM, and Flash:

```
# ubxtool -v 1 -w 1 -P 29.20 -z CFG-UART1-ENABLED,0,5
```

Or run:

```
# echo -ne
"\xb5\x62\x06\x8a\x09\x00\x00\x05\x00\x00\x05\x00\x52\x10\x00\x05\x80" > /dev/
gnssX
```

2. Disable UART2 in RAM, and Flash:

```
# ubxtool -v 3 -w 1 -P 29.20 -z CFG-UART2-ENABLED,0,5
```

Or run:

```
# echo -ne
"\xb5\x62\x06\x8a\x09\x00\x00\x05\x00\x00\x05\x00\x53\x10\x00\x06\x83" > /dev/
gnssX
```

- If you have AppArmor in your OS, it might block your access to the GNSS interfaces. To avoid that, in your `/etc/apparmor.d/usr.sbin.gpsd` file, add `/dev/gpsd[0-9] rw` and `/dev/gnss[0-9] rw`.
- In some cases, when GNSS loses the antenna reference, the GNSS might output for couple of seconds the 1PPS signal and NMEA messages. To more rapidly disqualify the 1PPS and NMEA messages, increase the filtering of GNSS receiver with **ubxtool** command:

```
# ubxtool -P 29.20 -v 1 -w 1 -z CFG-NAVSPG-OUTFIL_TACC,10,5
```

Or run:

```
#echo -ne
"\xb5\x62\x06\x8a\x0a\x00\x00\x05\x00\x00\xb4\x00\x11\x30\x0a\x00\x9e\x1b" >
/dev/gnssX
```

- If your GNSS receiver is not working correctly anymore due to `ubxtool -p reset` (factory reset command was issued), try to re-enable the default settings of the module by:

```
# ubxtool -z CFG-HW-ANT_CFG_VOLTCTRL,1 -z CFG-HW-ANT_CFG_SHORTDET,1 -z CFG-HW-
ANT_CFG_OPENDT,1 -z CFG-HW-ANT_CFG_RECOVER,1 -z CFG-HW-ANT_CFG_PWRDOWN,1 -z CFG-
UART1-ENABLED,0 -z CFG-UART2-ENABLED,0 -z CFG-SIGNAL-SBAS_ENA,0 -z CFG-SIGNAL-
SBAS_L1CA_ENA,0 -z CFG-SIGNAL-GAL_ENA,0 -z CFG-SIGNAL-GAL_E1_ENA,0 -z CFG-SIGNAL-
GAL_E5B_ENA,0 -z CFG-SIGNAL-BDS_ENA,0 -z CFG-SIGNAL-BDS_B1_ENA,0 -z CFG-SIGNAL-
BDS_B2_ENA,0 -z CFG-SIGNAL-GLO_ENA,0 -z CFG-SIGNAL-GLO_L1_ENA,0 -z CFG-SIGNAL-
GLO_L2_ENA,0 -z CFG-MSGOUT-NMEA_ID_GSV_I2C,0 -z CFG-MSGOUT-NMEA_ID_GLL_I2C,0 -z
CFG-MSGOUT-NMEA_ID_VTG_I2C,0 -z CFG-MSGOUT-NMEA_ID_ZDA_I2C,0 -z CFG-MSGOUT-
NMEA_ID_GSA_I2C,0 -P 29.20 -w 3
```

or run:

```
#echo -ne
"\xb5\x62\x06\x8a\x27\x00\x00\x07\x00\x00\x2e\x00\xa3\x10\x01\x2f\x
00\xa3\x10\x01\x31\x00\xa3\x10\x01\x35\x00\xa3\x10\x01\x33\x00\xa
3\x10\x01\x05\x00\x52\x10\x00\x05\x00\x53\x10\x00\x07\x8b" > /dev/
gnssX
```

and then:

```
#echo -ne
"\xb5\x62\x06\x8a\x54\x00\x00\x07\x00\x00\x20\x00\x31\x10\x00\x05\x
00\x31\x10\x00\x21\x00\x31\x10\x00\x07\x00\x31\x10\x00\x0a\x00\x3
1\x10\x00\x22\x00\x31\x10\x00\x0d\x00\x31\x10\x00\x0e\x00\x31\x10\x
00\x25\x00\x31\x10\x00\x18\x00\x31\x10\x00\x1a\x00\x31\x10\x00\xc
```

```
4\x00\x91\x20\x00\xc9\x00\x91\x20\x00\xb0\x00\x91\x20\x00\xd8\x00\x91\x20\x00\xbf\x00\x91\x20\x00\xea\x74" > /dev/gnssX
```

**Note:** It is suggested to check with Intel representative in case of problems with resetting the GNSS module.

- Procedure to build adjtimex on all Linux system:

The Github program in <https://github.com/rogers0/adjtimex/tags> is majorly for Debian but user can download its source code for cross OS compiler for a benefit to Time Sync application.

Below is the procedure to build adjtimex on most of Linux OS:

```
# wget https://github.com/rogers0/adjtimex/archive/refs/tags/debian/1.29-11.tar.gz
# tar -xvf 1.29-11.tar.gz
# cd adjtimex-debian-1.29-11/
# ./configure
# make -j && make -j install
# adjtimex -p
    mode: 0
    offset: -314905
    frequency: -227775
    maxerror: 187000
    esterror: 0
    status: 8193
time_constant: 6
    precision: 1
    tolerance: 32768000
    tick: 10000
    raw time: 1699327999s 827878401us = 1699327999.827878401
```

For more operation for adjtimex see detail in "man adjtimex"

- LinuxPTP as a time sensitive API to the OS, it is important and critical that OS need response to all PTP traffic within expected response time (i.e. 100ns for PRTC or 30ns for ePRTC). User could experience unexpected time jump, PTP no response, unknown PTP status or system reboot itself during heavy system workload and PTP workload simultaneously. User shall take care OS RAS (Reliability, Accessibility, Stability) from the beginning along with any heavy workload and time sensitive task (i.e. PTP or Synce).

In Linux Kernel, there are multiple settings that OS will trigger memory data flush to sync all run time data into file system or persistent memory.

Below example shows how to manage dirty data and configure the Kernel behavior:

```
# sysctl -a --pattern dirty\|hung
kernel.hung_task_all_cpu_backtrace = 0
kernel.hung_task_check_count = 4194304
kernel.hung_task_check_interval_secs = 0
kernel.hung_task_panic = 1
kernel.hung_task_timeout_secs = 120
kernel.hung_task_warnings = 10
vm.dirty_background_bytes = 0
```

```
vm.dirty_background_ratio = 10  
vm.dirty_bytes = 0  
vm.dirty_expire_centisecs = 3000  
vm.dirty_ratio = 40  
vm.dirty_writeback_centisecs = 500  
vm.dirtytime_expire_seconds = 43200
```

Above shows default setting, user can tune the `dirty_ratio` to lower value to get shorter “freeze” time of kernel; also a longer `hung_task_timeout_secs` can prevent kernel to auto-reboot.

Refer to <https://docs.kernel.org/admin-guide/sysctl/vm.html> for more details.

If you get:

```
ptp4l[6855.691]: port 1 (ens3f0): have SYNC 25158, expecting FOLLOW_UP but got SYNC  
25159, dropping  
ptp4l[6855.713]: port 1 (ens3f0): delay timeout  
ptp4l[6855.751]: port 1 (ens3f0): have SYNC 25159, expecting FOLLOW_UP but got SYNC  
25160, dropping  
ptp4l[6855.799]: port 1 (ens3f0): delay timeout  
ptp4l[6855.811]: port 1 (ens3f0): have SYNC 25160, expecting FOLLOW_UP but got SYNC  
25161, dropping  
ptp4l[6855.841]: port 1 (ens3f0): delay timeout  
ptp4l[6855.871]: port 1 (ens3f0): have SYNC 25161, expecting FOLLOW_UP but got SYNC  
25162, dropping
```

means you are using a one step TimeTransmitter partner, and the `assume_two_step` parameter in the config file should be set to 0.

If you see **ts2phc[609113.074]: UTC-TAI offset not set in system! Trying to revert to leapfile,** then try to use an older version of the `ts2phc` utility.



**NOTE:**      *This page intentionally left blank.*

## Appendix B Glossary and Acronyms

**Table 8. Definition of Terms**

Term	Definition
AAU	Active Antenna Unit
BBU	Baseband Unit
BC	Boundary Clock
BMC	Best Main Clock
CN	Core Network
CPRI	Common Public Radio Interface
CU	Centralized Unit
DU	Distributed Unit
EEC	Ethernet Equipment Clock
eMBB	Enhanced Mobile Broadband
EPC	Evolved Packet Core
Extts	External Timestamp
GMC	Grand Main Clock
GNSS	Global Navigation Satellite System (include GPS, Galileo, Glonass, Beidou, QZSS, and NavIC)
MIMO	Multiple-Input Multiple-Output
mMTC	Massive Machine Type Communication
ms	Milliseconds
NGCN	Next Generation Core Network
ns	Nanoseconds
NTP	Network Time Protocol
OC	Ordinary Clock
OCXO	Oven-Controlled Crystal Oscillator
OTII	Open Telecom IT Infrastructure
PDPC	Packet Data Convergence Protocol
PHC	PTP Hardware Clock
ppb	Parts Per Billion
ppm	Parts Per Million
PRC	Primary Reference Clock
PTP	Precision Time Protocol
ptp4l	PTP for Linux
RAN	Radio Access Network
RU	Radio Unit
S	Seconds
SSU	Synchronization Supply Unit
SyncE	Synchronous Ethernet
TC	Transparent Clock

**Table 8. Definition of Terms [continued]**

Term	Definition
ToD	Time of Day
ToS	Top of Second
uRLLC	Ultra-Reliable and Low Latency Communications
μs	Microseconds



**NOTE:**      *This page intentionally left blank.*



## LEGAL

---

No license (express or implied, by estoppel or otherwise) to any intellectual property rights is granted by this document.

This document (and any related software) is Intel copyrighted material, and your use is governed by the express license under which it is provided to you. Unless the license provides otherwise, you may not use, modify, copy, publish, distribute, disclose or transmit this document (and related materials) without Intel's prior written permission. This document (and related materials) is provided as is, with no express or implied warranties, other than those that are expressly stated in the license.

Intel disclaims all express and implied warranties, including without limitation, the implied warranties of merchantability, fitness for a particular purpose, and non-infringement, as well as any warranty arising from course of performance, course of dealing, or usage in trade.

This document contains information on products, services and/or processes in development. All information provided here is subject to change without notice. Contact your Intel representative to obtain the latest forecast, schedule, specifications and roadmaps.

The products and services described may contain defects or errors which may cause deviations from published specifications.

Copies of documents that are referenced in this document can be obtained by visiting the [Intel Resource and Documentation Center](#).

Intel and the Intel logo are trademarks of Intel Corporation in the U.S. and/or other countries.

Other names and brands may be claimed as the property of others.

© 2022-2024 Intel Corporation.