

Operating Conditions

Cyclone® devices are offered in both commercial, industrial, and extended temperature grades. However, industrial-grade and extended-temperature-grade devices may have limited speed-grade availability.

Tables 4–1 through 4–16 provide information on absolute maximum ratings, recommended operating conditions, DC operating conditions, and capacitance for Cyclone devices.

Table 4–1. Cyclone Device Absolute Maximum Ratings *Notes (1), (2)*

Symbol	Parameter	Conditions	Minimum	Maximum	Unit
V_{CCINT}	Supply voltage	With respect to ground (3)	–0.5	2.4	V
V_{CCIO}			–0.5	4.6	V
V_{CCA}	Supply voltage	With respect to ground (3)	–0.5	2.4	V
V_I	DC input voltage		–0.5	4.6	V
I_{OUT}	DC output current, per pin		–25	25	mA
T_{STG}	Storage temperature	No bias	–65	150	°C
T_{AMB}	Ambient temperature	Under bias	–65	135	°C
T_J	Junction temperature	BGA packages under bias	—	135	°C

Table 4–2. Cyclone Device Recommended Operating Conditions (Part 1 of 2)

Symbol	Parameter	Conditions	Minimum	Maximum	Unit
V_{CCINT}	Supply voltage for internal logic and input buffers	(4)	1.425	1.575	V
V_{CCIO}	Supply voltage for output buffers, 3.3-V operation	(4)	3.00	3.60	V
	Supply voltage for output buffers, 2.5-V operation	(4)	2.375	2.625	V
	Supply voltage for output buffers, 1.8-V operation	(4)	1.71	1.89	V
	Supply voltage for output buffers, 1.5-V operation	(4)	1.4	1.6	V
V_I	Input voltage	(3), (5)	–0.5	4.1	V

Table 4–2. Cyclone Device Recommended Operating Conditions (Part 2 of 2)

Symbol	Parameter	Conditions	Minimum	Maximum	Unit
V_O	Output voltage		0	V_{CCIO}	V
T_J	Operating junction temperature	For commercial use	0	85	° C
		For industrial use	–40	100	° C
		For extended-temperature use	–40	125	° C

Table 4–3. Cyclone Device DC Operating Conditions *Note (6)*

Symbol	Parameter	Conditions	Minimum	Typical	Maximum	Unit
I_I	Input pin leakage current	$V_I = V_{CCIOmax}$ to 0 V (8)	–10	—	10	μ A
I_{OZ}	Tri-stated I/O pin leakage current	$V_O = V_{CCIOmax}$ to 0 V (8)	–10	—	10	μ A
I_{CC0}	V_{CC} supply current (standby) (All M4K blocks in power-down mode) (7)	EP1C3	—	4	—	mA
		EP1C4	—	6	—	mA
		EP1C6	—	6	—	mA
		EP1C12	—	8	—	mA
		EP1C20	—	12	—	mA
R_{CONF} (9)	Value of I/O pin pull-up resistor before and during configuration	$V_I = 0$ V; $V_{CCIO} = 3.3$ V	15	25	50	k Ω
		$V_I = 0$ V; $V_{CCIO} = 2.5$ V	20	45	70	k Ω
		$V_I = 0$ V; $V_{CCIO} = 1.8$ V	30	65	100	k Ω
		$V_I = 0$ V; $V_{CCIO} = 1.5$ V	50	100	150	k Ω
	Recommended value of I/O pin external pull-down resistor before and during configuration	—	—	1	2	k Ω

Table 4–4. LVTTL Specifications

Symbol	Parameter	Conditions	Minimum	Maximum	Unit
V_{CCIO}	Output supply voltage	—	3.0	3.6	V
V_{IH}	High-level input voltage	—	1.7	4.1	V
V_{IL}	Low-level input voltage	—	–0.5	0.7	V
V_{OH}	High-level output voltage	$I_{OH} = -4$ to -24 mA (11)	2.4	—	V
V_{OL}	Low-level output voltage	$I_{OL} = 4$ to 24 mA (11)	—	0.45	V

Table 4–5. LVCMOS Specifications

Symbol	Parameter	Conditions	Minimum	Maximum	Unit
V_{CCIO}	Output supply voltage	—	3.0	3.6	V
V_{IH}	High-level input voltage	—	1.7	4.1	V
V_{IL}	Low-level input voltage	—	-0.5	0.7	V
V_{OH}	High-level output voltage	$V_{CCIO} = 3.0$, $I_{OH} = -0.1$ mA	$V_{CCIO} - 0.2$	—	V
V_{OL}	Low-level output voltage	$V_{CCIO} = 3.0$, $I_{OL} = 0.1$ mA	—	0.2	V

Table 4–6. 2.5-V I/O Specifications

Symbol	Parameter	Conditions	Minimum	Maximum	Unit
V_{CCIO}	Output supply voltage	—	2.375	2.625	V
V_{IH}	High-level input voltage	—	1.7	4.1	V
V_{IL}	Low-level input voltage	—	-0.5	0.7	V
V_{OH}	High-level output voltage	$I_{OH} = -0.1$ mA	2.1	—	V
		$I_{OH} = -1$ mA	2.0	—	V
		$I_{OH} = -2$ to -16 mA (11)	1.7	—	V
V_{OL}	Low-level output voltage	$I_{OL} = 0.1$ mA	—	0.2	V
		$I_{OH} = 1$ mA	—	0.4	V
		$I_{OH} = 2$ to 16 mA (11)	—	0.7	V

Table 4–7. 1.8-V I/O Specifications

Symbol	Parameter	Conditions	Minimum	Maximum	Unit
V_{CCIO}	Output supply voltage	—	1.65	1.95	V
V_{IH}	High-level input voltage	—	$0.65 \times V_{CCIO}$	2.25 (12)	V
V_{IL}	Low-level input voltage	—	-0.3	$0.35 \times V_{CCIO}$	V
V_{OH}	High-level output voltage	$I_{OH} = -2$ to -8 mA (11)	$V_{CCIO} - 0.45$	—	V
V_{OL}	Low-level output voltage	$I_{OL} = 2$ to 8 mA (11)	—	0.45	V

Table 4–8. 1.5-V I/O Specifications

Symbol	Parameter	Conditions	Minimum	Maximum	Unit
V_{CCIO}	Output supply voltage	—	1.4	1.6	V
V_{IH}	High-level input voltage	—	$0.65 \times V_{CCIO}$	$V_{CCIO} + 0.3$ (12)	V
V_{IL}	Low-level input voltage	—	-0.3	$0.35 \times V_{CCIO}$	V
V_{OH}	High-level output voltage	$I_{OH} = -2 \text{ mA}$ (11)	$0.75 \times V_{CCIO}$	—	V
V_{OL}	Low-level output voltage	$I_{OL} = 2 \text{ mA}$ (11)	—	$0.25 \times V_{CCIO}$	V

Table 4–9. 2.5-V LVDS I/O Specifications Note (13)

Symbol	Parameter	Conditions	Minimum	Typical	Maximum	Unit
V_{CCIO}	I/O supply voltage	—	2.375	2.5	2.625	V
V_{OD}	Differential output voltage	$R_L = 100 \Omega$	250	—	550	mV
ΔV_{OD}	Change in V_{OD} between high and low	$R_L = 100 \Omega$	—	—	50	mV
V_{OS}	Output offset voltage	$R_L = 100 \Omega$	1.125	1.25	1.375	V
ΔV_{OS}	Change in V_{OS} between high and low	$R_L = 100 \Omega$	—	—	50	mV
V_{TH}	Differential input threshold	$V_{CM} = 1.2 \text{ V}$	-100	—	100	mV
V_{IN}	Receiver input voltage range	—	0.0	—	2.4	V
R_L	Receiver differential input resistor	—	90	100	110	Ω

Table 4–10. 3.3-V PCI Specifications (Part 1 of 2)

Symbol	Parameter	Conditions	Minimum	Typical	Maximum	Unit
V_{CCIO}	Output supply voltage	—	3.0	3.3	3.6	V
V_{IH}	High-level input voltage	—	$0.5 \times V_{CCIO}$	—	$V_{CCIO} + 0.5$	V
V_{IL}	Low-level input voltage	—	-0.5	—	$0.3 \times V_{CCIO}$	V

Table 4–10. 3.3-V PCI Specifications (Part 2 of 2)

Symbol	Parameter	Conditions	Minimum	Typical	Maximum	Unit
V_{OH}	High-level output voltage	$I_{OUT} = -500 \mu A$	$0.9 \times V_{CCIO}$	—	—	V
V_{OL}	Low-level output voltage	$I_{OUT} = 1,500 \mu A$	—	—	$0.1 \times V_{CCIO}$	V

Table 4–11. SSTL-2 Class I Specifications

Symbol	Parameter	Conditions	Minimum	Typical	Maximum	Unit
V_{CCIO}	Output supply voltage	—	2.375	2.5	2.625	V
V_{TT}	Termination voltage	—	$V_{REF} - 0.04$	V_{REF}	$V_{REF} + 0.04$	V
V_{REF}	Reference voltage	—	1.15	1.25	1.35	V
V_{IH}	High-level input voltage	—	$V_{REF} + 0.18$	—	3.0	V
V_{IL}	Low-level input voltage	—	-0.3	—	$V_{REF} - 0.18$	V
V_{OH}	High-level output voltage	$I_{OH} = -8.1 \text{ mA}$ (11)	$V_{TT} + 0.57$	—	—	V
V_{OL}	Low-level output voltage	$I_{OL} = 8.1 \text{ mA}$ (11)	—	—	$V_{TT} - 0.57$	V

Table 4–12. SSTL-2 Class II Specifications

Symbol	Parameter	Conditions	Minimum	Typical	Maximum	Unit
V_{CCIO}	Output supply voltage	—	2.3	2.5	2.7	V
V_{TT}	Termination voltage	—	$V_{REF} - 0.04$	V_{REF}	$V_{REF} + 0.04$	V
V_{REF}	Reference voltage	—	1.15	1.25	1.35	V
V_{IH}	High-level input voltage	—	$V_{REF} + 0.18$	—	$V_{CCIO} + 0.3$	V
V_{IL}	Low-level input voltage	—	-0.3	—	$V_{REF} - 0.18$	V
V_{OH}	High-level output voltage	$I_{OH} = -16.4 \text{ mA}$ (11)	$V_{TT} + 0.76$	—	—	V
V_{OL}	Low-level output voltage	$I_{OL} = 16.4 \text{ mA}$ (11)	—	—	$V_{TT} - 0.76$	V

Table 4–13. SSTL-3 Class I Specifications (Part 1 of 2)

Symbol	Parameter	Conditions	Minimum	Typical	Maximum	Unit
V_{CCIO}	Output supply voltage	—	3.0	3.3	3.6	V
V_{TT}	Termination voltage	—	$V_{REF} - 0.05$	V_{REF}	$V_{REF} + 0.05$	V

Table 4–13. SSTL-3 Class I Specifications (Part 2 of 2)

Symbol	Parameter	Conditions	Minimum	Typical	Maximum	Unit
V_{REF}	Reference voltage	—	1.3	1.5	1.7	V
V_{IH}	High-level input voltage	—	$V_{REF} + 0.2$	—	$V_{CCIO} + 0.3$	V
V_{IL}	Low-level input voltage	—	-0.3	—	$V_{REF} - 0.2$	V
V_{OH}	High-level output voltage	$I_{OH} = -8 \text{ mA}$ (11)	$V_{TT} + 0.6$	—	—	V
V_{OL}	Low-level output voltage	$I_{OL} = 8 \text{ mA}$ (11)	—	—	$V_{TT} - 0.6$	V

Table 4–14. SSTL-3 Class II Specifications

Symbol	Parameter	Conditions	Minimum	Typical	Maximum	Unit
V_{CCIO}	Output supply voltage	—	3.0	3.3	3.6	V
V_{TT}	Termination voltage	—	$V_{REF} - 0.05$	V_{REF}	$V_{REF} + 0.05$	V
V_{REF}	Reference voltage	—	1.3	1.5	1.7	V
V_{IH}	High-level input voltage	—	$V_{REF} + 0.2$	—	$V_{CCIO} + 0.3$	V
V_{IL}	Low-level input voltage	—	-0.3	—	$V_{REF} - 0.2$	V
V_{OH}	High-level output voltage	$I_{OH} = -16 \text{ mA}$ (11)	$V_{TT} + 0.8$	—	—	V
V_{OL}	Low-level output voltage	$I_{OL} = 16 \text{ mA}$ (11)	—	—	$V_{TT} - 0.8$	V

Table 4–15. Bus Hold Parameters

Parameter	Conditions	V_{CCIO} Level								Unit
		1.5 V		1.8 V		2.5 V		3.3 V		
		Min	Max	Min	Max	Min	Max	Min	Max	
Low sustaining current	$V_{IN} > V_{IL}$ (maximum)	—	—	30	—	50	—	70	—	μA
High sustaining current	$V_{IN} < V_{IH}$ (minimum)	—	—	-30	—	-50	—	-70	—	μA
Low overdrive current	$0 \text{ V} < V_{IN} < V_{CCIO}$	—	—	—	200	—	300	—	500	μA
High overdrive current	$0 \text{ V} < V_{IN} < V_{CCIO}$	—	—	—	-200	—	-300	—	-500	μA

Table 4–16. Cyclone Device Capacitance *Note (14)*

Symbol	Parameter	Typical	Unit
C_{IO}	Input capacitance for user I/O pin	4.0	pF
C_{LVDS}	Input capacitance for dual-purpose LVDS/user I/O pin	4.7	pF
C_{VREF}	Input capacitance for dual-purpose V_{REF} /user I/O pin.	12.0	pF
C_{DPCLK}	Input capacitance for dual-purpose $DPCLK$ /user I/O pin.	4.4	pF
C_{CLK}	Input capacitance for CLK pin.	4.7	pF

Notes to Tables 4–1 through 4–16:

- (1) Refer to the *Operating Requirements for Altera Devices Data Sheet*.
- (2) Conditions beyond those listed in Table 4–1 may cause permanent damage to a device. Additionally, device operation at the absolute maximum ratings for extended periods of time may have adverse effects on the device.
- (3) Minimum DC input is -0.5 V. During transitions, the inputs may undershoot to -2.0 V or overshoot to 4.6 V for input currents less than 100 mA and periods shorter than 20 ns.
- (4) Maximum V_{CC} rise time is 100 ms, and V_{CC} must rise monotonically.
- (5) All pins, including dedicated inputs, clock, I/O, and JTAG pins, may be driven before V_{CCINT} and V_{CCIO} are powered.
- (6) Typical values are for $T_A = 25^\circ$ C, $V_{CCINT} = 1.5$ V, and $V_{CCIO} = 1.5$ V, 1.8 V, 2.5 V, and 3.3 V.
- (7) $V_I =$ ground, no load, no toggling inputs.
- (8) This value is specified for normal device operation. The value may vary during power-up. This applies for all V_{CCIO} settings (3.3 , 2.5 , 1.8 , and 1.5 V).
- (9) R_{CONF} is the measured value of internal pull-up resistance when the I/O pin is tied directly to GND. R_{CONF} value will be lower if an external source drives the pin higher than V_{CCIO} .
- (10) Pin pull-up resistance values will lower if an external source drives the pin higher than V_{CCIO} .
- (11) Drive strength is programmable according to values in *Cyclone Architecture* chapter in the *Cyclone Device Handbook*.
- (12) Overdrive is possible when a 1.5 V or 1.8 V and a 2.5 V or 3.3 V input signal feeds an input pin. Turn on “Allow voltage overdrive” for LVTTTL/LVCMOS input pins in the Assignments > Device > Device and Pin Options > Pin Placement tab when a device has this I/O combination. However, higher leakage current is expected.
- (13) The Cyclone LVDS interface requires a resistor network outside of the transmitter channels.
- (14) Capacitance is sample-tested only. Capacitance is measured using time-domain reflections (TDR). Measurement accuracy is within ± 0.5 pF.

Power Consumption

Designers can use the Altera web Early Power Estimator to estimate the device power.

Cyclone devices require a certain amount of power-up current to successfully power up because of the nature of the leading-edge process on which they are fabricated. Table 4–17 shows the maximum power-up current required to power up a Cyclone device.

Device	Commercial Specification	Industrial Specification	Unit
EP1C3	150	180	mA
EP1C4	150	180	mA
EP1C6	175	210	mA
EP1C12	300	360	mA
EP1C20	500	600	mA

Notes to Table 4–17:

- (1) The Cyclone devices (except for the EP1C20 device) meet the power up specification for Mini PCI.
- (2) The lot codes 9G0082 to 9G2999, or 9G3109 and later comply to the specifications in Table 4–17 and meet the Mini PCI specification. Lot codes appear at the top of the device.
- (3) The lot codes 9H0004 to 9H29999, or 9H3014 and later comply to the specifications in this table and meet the Mini PCI specification. Lot codes appear at the top of the device.

Designers should select power supplies and regulators that can supply this amount of current when designing with Cyclone devices. This specification is for commercial operating conditions. Measurements were performed with an isolated Cyclone device on the board. Decoupling capacitors were not used in this measurement. To factor in the current for decoupling capacitors, sum up the current for each capacitor using the following equation:

$$I = C (dV/dt)$$

The exact amount of current that is consumed varies according to the process, temperature, and power ramp rate. If the power supply or regulator can supply more current than required, the Cyclone device may consume more current than the maximum current specified in Table 4–17. However, the device does not require any more current to successfully power up than what is listed in Table 4–17.

The duration of the I_{CCINT} power-up requirement depends on the V_{CCINT} voltage supply rise time. The power-up current consumption drops when the V_{CCINT} supply reaches approximately 0.75 V. For example, if the V_{CCINT} rise time has a linear rise of 15 ms, the current consumption spike drops by 7.5 ms.

Typically, the user-mode current during device operation is lower than the power-up current in [Table 4-17](#). Altera recommends using the Cyclone Power Calculator, available on the Altera web site, to estimate the user-mode I_{CCINT} consumption and then select power supplies or regulators based on the higher value.

Timing Model

The DirectDrive technology and MultiTrack interconnect ensure predictable performance, accurate simulation, and accurate timing analysis across all Cyclone device densities and speed grades. This section describes and specifies the performance, internal, external, and PLL timing specifications.

All specifications are representative of worst-case supply voltage and junction temperature conditions.

Preliminary and Final Timing

Timing models can have either preliminary or final status. The Quartus® II software issues an informational message during the design compilation if the timing models are preliminary. [Table 4-18](#) shows the status of the Cyclone device timing models.

Preliminary status means the timing model is subject to change. Initially, timing numbers are created using simulation results, process data, and other known parameters. These tests are used to make the preliminary numbers as close to the actual timing parameters as possible.

Final timing numbers are based on actual device operation and testing. These numbers reflect the actual performance of the device under worst-case voltage and junction temperature conditions.

Table 4-18. Cyclone Device Timing Model Status

Device	Preliminary	Final
EP1C3	—	✓
EP1C4	—	✓
EP1C6	—	✓
EP1C12	—	✓
EP1C20	—	✓

Performance

The maximum internal logic array clock tree frequency is limited to the specifications shown in [Table 4-19](#).

Parameter	Definition	-6 Speed Grade			-7 Speed Grade			-8 Speed Grade			Units
		Min	Typ	Max	Min	Typ	Max	Min	Typ	Max	
Clock tree f_{MAX}	Maximum frequency that the clock tree can support for clocking registered logic	—	—	405	—	—	320	—	—	275	MHz

[Table 4-20](#) shows the Cyclone device performance for some common designs. All performance values were obtained with the Quartus II software compilation of library of parameterized modules (LPM) functions or megafunctions. These performance values are based on EP1C6 devices in 144-pin TQFP packages.

Resource Used	Design Size and Function	Mode	Resources Used			Performance		
			LEs	M4K Memory Bits	M4K Memory Blocks	-6 Speed Grade (MHz)	-7 Speed Grade (MHz)	-8 Speed Grade (MHz)
LE	16-to-1 multiplexer	—	21	—	—	405.00	320.00	275.00
	32-to-1 multiplexer	—	44	—	—	317.36	284.98	260.15
	16-bit counter	—	16	—	—	405.00	320.00	275.00
	64-bit counter (1)	—	66	—	—	208.99	181.98	160.75

Table 4–20. Cyclone Device Performance

Resource Used	Design Size and Function	Mode	Resources Used			Performance		
			LEs	M4K Memory Bits	M4K Memory Blocks	-6 Speed Grade (MHz)	-7 Speed Grade (MHz)	-8 Speed Grade (MHz)
M4K memory block	RAM 128 × 36 bit	Single port	—	4,608	1	256.00	222.67	197.01
	RAM 128 × 36 bit	Simple dual-port mode	—	4,608	1	255.95	222.67	196.97
	RAM 256 × 18 bit	True dual-port mode	—	4,608	1	255.95	222.67	196.97
	FIFO 128 × 36 bit	—	40	4,608	1	256.02	222.67	197.01
	Shift register 9 × 4 × 128	Shift register	11	4,536	1	255.95	222.67	196.97

Note to [Table 4–20](#):

- (1) The performance numbers for this function are from an EP1C6 device in a 240-pin PQFP package.

Internal Timing Parameters

Internal timing parameters are specified on a speed grade basis independent of device density. [Tables 4–21](#) through [4–24](#) describe the Cyclone device internal timing microparameters for LEs, IOEs, M4K memory structures, and MultiTrack interconnects.

Table 4–21. LE Internal Timing Microparameter Descriptions

Symbol	Parameter
t_{SU}	LE register setup time before clock
t_H	LE register hold time after clock
t_{CO}	LE register clock-to-output delay
t_{LUT}	LE combinatorial LUT delay for data-in to data-out
t_{CLR}	Minimum clear pulse width
t_{PRE}	Minimum preset pulse width
t_{CLKHL}	Minimum clock high or low time

Table 4–22. IOE Internal Timing Microparameter Descriptions

Symbol	Parameter
t_{SU}	IOE input and output register setup time before clock
t_H	IOE input and output register hold time after clock
t_{CO}	IOE input and output register clock-to-output delay
$t_{PIN2COMBOUT_R}$	Row input pin to IOE combinatorial output
$t_{PIN2COMBOUT_C}$	Column input pin to IOE combinatorial output
$t_{COMBIN2PIN_R}$	Row IOE data input to combinatorial output pin
$t_{COMBIN2PIN_C}$	Column IOE data input to combinatorial output pin
t_{CLR}	Minimum clear pulse width
t_{PRE}	Minimum preset pulse width
t_{CLKHL}	Minimum clock high or low time

Table 4–23. M4K Block Internal Timing Microparameter Descriptions

Symbol	Parameter
t_{M4KRC}	Synchronous read cycle time
t_{M4KWC}	Synchronous write cycle time
$t_{M4KWRESU}$	Write or read enable setup time before clock
$t_{M4KWEREH}$	Write or read enable hold time after clock
$t_{M4KBESU}$	Byte enable setup time before clock
t_{M4KBEH}	Byte enable hold time after clock
$t_{M4KDATAASU}$	A port data setup time before clock
$t_{M4KDATAAH}$	A port data hold time after clock
$t_{M4KADDRASU}$	A port address setup time before clock
$t_{M4KADDRAH}$	A port address hold time after clock
$t_{M4KDATABSU}$	B port data setup time before clock
$t_{M4KDATA BH}$	B port data hold time after clock
$t_{M4KADDRBSU}$	B port address setup time before clock
$t_{M4KADDRBH}$	B port address hold time after clock
$t_{M4KDATA CO1}$	Clock-to-output delay when using output registers
$t_{M4KDATA CO2}$	Clock-to-output delay without output registers
$t_{M4KCLKHL}$	Minimum clock high or low time
t_{M4KCLR}	Minimum clear pulse width

Table 4–24. Routing Delay Internal Timing Microparameter Descriptions

Symbol	Parameter
t_{R4}	Delay for an R4 line with average loading; covers a distance of four LAB columns
t_{C4}	Delay for an C4 line with average loading; covers a distance of four LAB rows
t_{LOCAL}	Local interconnect delay

Figure 4–1 shows the memory waveforms for the M4K timing parameters shown in Table 4–23.

Figure 4–1. Dual-Port RAM Timing Microparameter Waveform

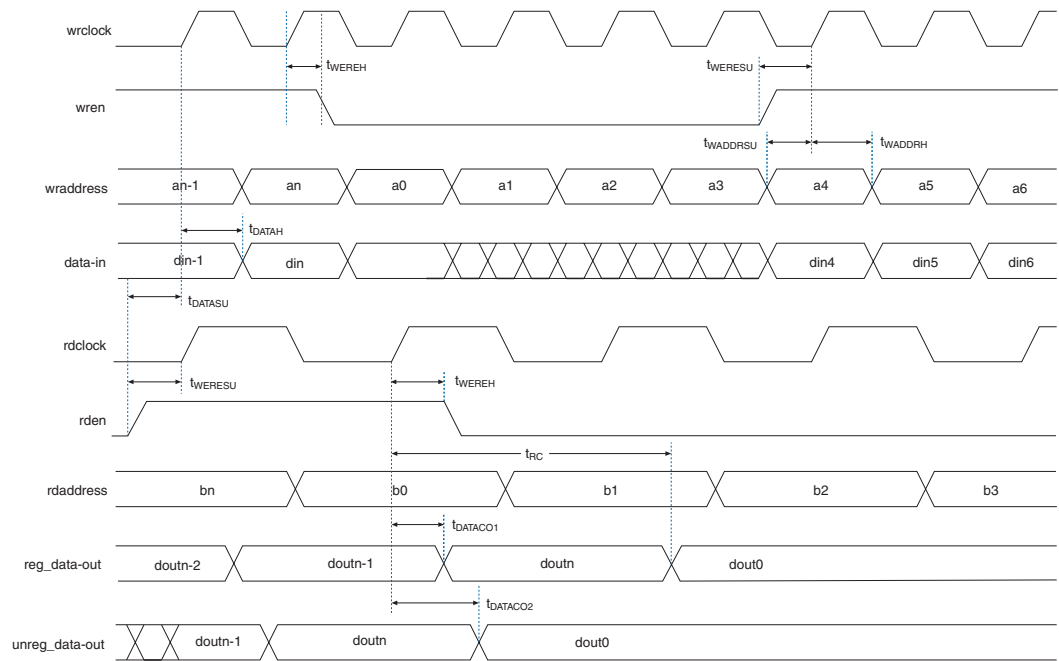

Internal timing parameters are specified on a speed grade basis independent of device density. Tables 4–25 through 4–28 show the internal timing microparameters for LEs, IOEs, TriMatrix memory structures, DSP blocks, and MultiTrack interconnects.

Table 4–25. LE Internal Timing Microparameters

Symbol	-6		-7		-8		Unit
	Min	Max	Min	Max	Min	Max	
t_{SU}	29	—	33	—	37	—	ps
t_H	12	—	13	—	15	—	ps
t_{CO}	—	173	—	198	—	224	ps
t_{LUT}	—	454	—	522	—	590	ps
t_{CLR}	129	—	148	—	167	—	ps
t_{PRE}	129	—	148	—	167	—	ps
t_{CLKHL}	1,234	—	1,562	—	1,818	—	ps

Table 4–26. IOE Internal Timing Microparameters

Symbol	-6		-7		-8		Unit
	Min	Max	Min	Max	Min	Max	
t_{SU}	348	—	400	—	452	—	ps
t_H	0	—	0	—	0	—	ps
t_{CO}	—	511	—	587	—	664	ps
$t_{PIN2COMBOUT_R}$	—	1,130	—	1,299	—	1,469	ps
$t_{PIN2COMBOUT_C}$	—	1,135	—	1,305	—	1,475	ps
$t_{COMBIN2PIN_R}$	—	2,627	—	3,021	—	3,415	ps
$t_{COMBIN2PIN_C}$	—	2,615	—	3,007	—	3,399	ps
t_{CLR}	280	—	322	—	364	—	ps
t_{PRE}	280	—	322	—	364	—	ps
t_{CLKHL}	1,234	—	1,562	—	1,818	—	ps

Table 4–27. M4K Block Internal Timing Microparameters

Symbol	-6		-7		-8		Unit
	Min	Max	Min	Max	Min	Max	
t_{M4KRC}	—	4,379		5,035		5,691	ps
t_{M4KWC}	—	2,910		3,346		3,783	ps
$t_{M4KWERSU}$	72	—	82	—	93	—	ps
$t_{M4KWEREH}$	43	—	49	—	55	—	ps
$t_{M4KBESU}$	72	—	82	—	93	—	ps
t_{M4KBEH}	43	—	49	—	55	—	ps
$t_{M4KDATAASU}$	72	—	82	—	93	—	ps
$t_{M4KDATAAH}$	43	—	49	—	55	—	ps
$t_{M4KADDRASU}$	72	—	82	—	93	—	ps
$t_{M4KADDRAH}$	43	—	49	—	55	—	ps
$t_{M4KDATABSU}$	72	—	82	—	93	—	ps
$t_{M4KDATA BH}$	43	—	49	—	55	—	ps
$t_{M4KADDRBSU}$	72	—	82	—	93	—	ps
$t_{M4KADDRBH}$	43	—	49	—	55	—	ps
$t_{M4KDATA CO1}$	—	621	—	714	—	807	ps
$t_{M4KDATA CO2}$	—	4,351	—	5,003	—	5,656	ps
$t_{M4KCLKHL}$	1,234	—	1,562	—	1,818	—	ps
t_{M4KCLR}	286	—	328	—	371	—	ps

Table 4–28. Routing Delay Internal Timing Microparameters

Symbol	-6		-7		-8		Unit
	Min	Max	Min	Max	Min	Max	
t_{R4}	—	261	—	300	—	339	ps
t_{C4}	—	338	—	388	—	439	ps
t_{LOCAL}	—	244	—	281	—	318	ps

External Timing Parameters

External timing parameters are specified by device density and speed grade. Figure 4–2 shows the timing model for bidirectional IOE pin timing. All registers are within the IOE.

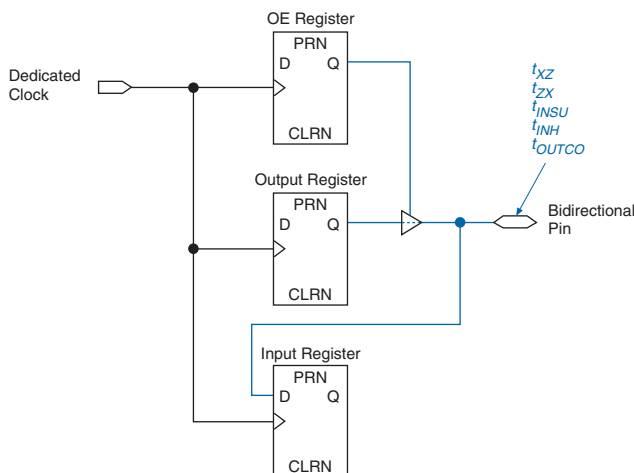
Figure 4–2. External Timing in Cyclone Devices

All external I/O timing parameters shown are for 3.3-V LVTTTL I/O standard with the maximum current strength and fast slew rate. For external I/O timing using standards other than LVTTTL or for different current strengths, use the I/O standard input and output delay adders in [Tables 4–40 through 4–44](#).

[Table 4–29](#) shows the external I/O timing parameters when using global clock networks.

Symbol	Parameter	Conditions
t_{INSU}	Setup time for input or bidirectional pin using IOE input register with global clock fed by CLK pin	—
t_{INH}	Hold time for input or bidirectional pin using IOE input register with global clock fed by CLK pin	—
t_{OUTCO}	Clock-to-output delay output or bidirectional pin using IOE output register with global clock fed by CLK pin	$C_{LOAD} = 10 \text{ pF}$
$t_{INSUPLL}$	Setup time for input or bidirectional pin using IOE input register with global clock fed by Enhanced PLL with default phase setting	—
t_{INHPLL}	Hold time for input or bidirectional pin using IOE input register with global clock fed by enhanced PLL with default phase setting	—

Table 4–29. Cyclone Global Clock External I/O Timing Parameters Notes (1), (2) (Part 2 of 2)

Symbol	Parameter	Conditions
t_{OUTCOPLL}	Clock-to-output delay output or bidirectional pin using IOE output register with global clock enhanced PLL with default phase setting	$C_{\text{LOAD}} = 10 \text{ pF}$

Notes to Table 4–29:

- (1) These timing parameters are sample-tested only.
- (2) These timing parameters are for IOE pins using a 3.3-V LVTTTL, 24-mA setting. Designers should use the Quartus II software to verify the external timing for any pin.

Tables 4–30 through 4–31 show the external timing parameters on column and row pins for EP1C3 devices.

Table 4–30. EP1C3 Column Pin Global Clock External I/O Timing Parameters

Symbol	-6 Speed Grade		-7 Speed Grade		-8 Speed Grade		Unit
	Min	Max	Min	Max	Min	Max	
t_{INSU}	3.085	—	3.547	—	4.009	—	ns
t_{INH}	0.000	—	0.000	—	0.000	—	ns
t_{OUTCO}	2.000	4.073	2.000	4.682	2.000	5.295	ns
t_{INSUPLL}	1.795	—	2.063	—	2.332	—	ns
t_{INHPLL}	0.000	—	0.000	—	0.000	—	ns
t_{OUTCOPLL}	0.500	2.306	0.500	2.651	0.500	2.998	ns

Table 4–31. EP1C3 Row Pin Global Clock External I/O Timing Parameters

Symbol	-6 Speed Grade		-7 Speed Grade		-8 Speed Grade		Unit
	Min	Max	Min	Max	Min	Max	
t_{INSU}	3.157	—	3.630	—	4.103	—	ns
t_{INH}	0.000	—	0.000	—	0.000	—	ns
t_{OUTCO}	2.000	3.984	2.000	4.580	2.000	5.180	ns
t_{INSUPLL}	1.867	—	2.146	—	2.426	—	ns
t_{INHPLL}	0.000	—	0.000	—	0.000	—	ns
t_{OUTCOPLL}	0.500	2.217	0.500	2.549	0.500	2.883	ns

Tables 4–32 through 4–33 show the external timing parameters on column and row pins for EP1C4 devices.

Table 4–32. EP1C4 Column Pin Global Clock External I/O Timing Parameters *Note (1)*

Symbol	-6 Speed Grade		-7 Speed Grade		-8 Speed Grade		Unit
	Min	Max	Min	Max	Min	Max	
t_{INSU}	2.471	—	2.841	—	3.210	—	ns
t_{INH}	0.000	—	0.000	—	0.000	—	ns
t_{OUTCO}	2.000	3.937	2.000	4.526	2.000	5.119	ns
t_{INSUPLL}	1.471	—	1.690	—	1.910	—	ns
t_{INHPLL}	0.000	—	0.000	—	0.000	—	ns
t_{OUTCOPLL}	0.500	2.080	0.500	2.392	0.500	2.705	ns

Table 4–33. EP1C4 Row Pin Global Clock External I/O Timing Parameters *Note (1)*

Symbol	-6 Speed Grade		-7 Speed Grade		-8 Speed Grade		Unit
	Min	Max	Min	Max	Min	Max	
t_{INSU}	2.600	—	2.990	—	3.379	—	ns
t_{INH}	0.000	—	0.000	—	0.000	—	ns
t_{OUTCO}	2.000	3.991	2.000	4.388	2.000	5.189	ns
t_{INSUPLL}	1.300	—	1.494	—	1.689	—	ns
t_{INHPLL}	0.000	—	0.000	—	0.000	—	ns
t_{OUTCOPLL}	0.500	2.234	0.500	2.569	0.500	2.905	ns

Note to Tables 4–32 and 4–33:

(1) Contact Altera Applications for EP1C4 device timing parameters.

Tables 4–34 through 4–35 show the external timing parameters on column and row pins for EP1C6 devices.

Table 4–34. EP1C6 Column Pin Global Clock External I/O Timing Parameters

Symbol	-6 Speed Grade		-7 Speed Grade		-8 Speed Grade		Unit
	Min	Max	Min	Max	Min	Max	
t_{INSU}	2.691	—	3.094	—	3.496	—	ns
t_{INH}	0.000	—	0.000	—	0.000	—	ns
t_{OUTCO}	2.000	3.917	2.000	4.503	2.000	5.093	ns
t_{INSUPLL}	1.513	—	1.739	—	1.964	—	ns
t_{INHPLL}	0.000	—	0.000	—	0.000	—	ns
t_{OUTCOPLL}	0.500	2.038	0.500	2.343	0.500	2.651	ns

Table 4–35. EP1C6 Row Pin Global Clock External I/O Timing Parameters

Symbol	-6 Speed Grade		-7 Speed Grade		-8 Speed Grade		Unit
	Min	Max	Min	Max	Min	Max	
t_{INSU}	2.774	—	3.190	—	3.605	—	ns
t_{INH}	0.000	—	0.000	—	0.000	—	ns
t_{OUTCO}	2.000	3.817	2.000	4.388	2.000	4.963	ns
t_{INSUPLL}	1.596	—	1.835	—	2.073	—	ns
t_{INHPLL}	0.000	—	0.000	—	0.000	—	ns
t_{OUTCOPLL}	0.500	1.938	0.500	2.228	0.500	2.521	ns

Tables 4–36 through 4–37 show the external timing parameters on column and row pins for EP1C12 devices.

Table 4–36. EP1C12 Column Pin Global Clock External I/O Timing Parameters (Part 1 of 2)

Symbol	-6 Speed Grade		-7 Speed Grade		-8 Speed Grade		Unit
	Min	Max	Min	Max	Min	Max	
t_{INSU}	2.510	—	2.885	—	3.259	—	ns
t_{INH}	0.000	—	0.000	—	0.000	—	ns
t_{OUTCO}	2.000	3.798	2.000	4.367	2.000	4.940	ns
t_{INSUPLL}	1.588	—	1.824	—	2.061	—	ns

Table 4–36. EP1C12 Column Pin Global Clock External I/O Timing Parameters (Part 2 of 2)

Symbol	-6 Speed Grade		-7 Speed Grade		-8 Speed Grade		Unit
	Min	Max	Min	Max	Min	Max	
t_{INHPLL}	0.000	—	0.000	—	0.000	—	ns
$t_{OUTCOPLL}$	0.500	1.663	0.500	1.913	0.500	2.164	ns

Table 4–37. EP1C12 Row Pin Global Clock External I/O Timing Parameters

Symbol	-6 Speed Grade		-7 Speed Grade		-8 Speed Grade		Unit
	Min	Max	Min	Max	Min	Max	
t_{INSU}	2.620	—	3.012	—	3.404	—	ns
t_{INH}	0.000	—	0.000	—	0.000	—	ns
t_{OUTCO}	2.000	3.671	2.000	4.221	2.000	4.774	ns
$t_{INSUPLL}$	1.698	—	1.951	—	2.206	—	ns
t_{INHPLL}	0.000	—	0.000	—	0.000	—	ns
$t_{OUTCOPLL}$	0.500	1.536	0.500	1.767	0.500	1.998	ns

Tables 4–38 through 4–39 show the external timing parameters on column and row pins for EP1C20 devices.

Table 4–38. EP1C20 Column Pin Global Clock External I/O Timing Parameters

Symbol	-6 Speed Grade		-7 Speed Grade		-8 Speed Grade		Unit
	Min	Max	Min	Max	Min	Max	
t_{INSU}	2.417	—	2.779	—	3.140	—	ns
t_{INH}	0.000	—	0.000	—	0.000	—	ns
t_{OUTCO}	2.000	3.724	2.000	4.282	2.000	4.843	ns
$t_{INSUPLL}$	1.417	—	1.629	—	1.840	—	ns
t_{INHPLL}	0.000	—	0.000	—	0.000	—	ns
$t_{OUTCOPLL}$	0.500	1.667	0.500	1.917	0.500	2.169	ns

Table 4–39. EP1C20 Row Pin Global Clock External I/O Timing Parameters

Symbol	-6 Speed Grade		-7 Speed Grade		-8 Speed Grade		Unit
	Min	Max	Min	Max	Min	Max	
t_{INSU}	2.417	—	2.779	—	3.140	—	ns
t_{INH}	0.000	—	0.000	—	0.000	—	ns
t_{OUTCO}	2.000	3.724	2.000	4.282	2.000	4.843	ns
t_{XZ}	—	3.645	—	4.191	—	4.740	ns
t_{ZX}	—	3.645	—	4.191	—	4.740	ns
t_{INSUPLL}	1.417	—	1.629	—	1.840	—	ns
t_{INHPLL}	0.000	—	0.000	—	0.000	—	ns
t_{OUTCOPLL}	0.500	1.667	0.500	1.917	0.500	2.169	ns
t_{XZPLL}	—	1.588	—	1.826	—	2.066	ns
t_{ZXPLL}	—	1.588	—	1.826	—	2.066	ns

External I/O Delay Parameters

External I/O delay timing parameters for I/O standard input and output adders and programmable input and output delays are specified by speed grade independent of device density.

Tables 4–40 through 4–45 show the adder delays associated with column and row I/O pins for all packages. If an I/O standard is selected other than LVTTTL 4 mA with a fast slew rate, add the selected delay to the external t_{CO} and t_{SU} I/O parameters shown in Tables 4–25 through 4–28.

Table 4–40. Cyclone I/O Standard Column Pin Input Delay Adders (Part 1 of 2)

I/O Standard	-6 Speed Grade		-7 Speed Grade		-8 Speed Grade		Unit
	Min	Max	Min	Max	Min	Max	
LVC MOS	—	0	—	0	—	0	ps
3.3-V LVTTTL	—	0	—	0	—	0	ps
2.5-V LVTTTL	—	27	—	31	—	35	ps
1.8-V LVTTTL	—	182	—	209	—	236	ps
1.5-V LVTTTL	—	278	—	319	—	361	ps
SSTL-3 class I	—	–250	—	–288	—	–325	ps
SSTL-3 class II	—	–250	—	–288	—	–325	ps
SSTL-2 class I	—	–278	—	–320	—	–362	ps

Table 4–40. Cyclone I/O Standard Column Pin Input Delay Adders (Part 2 of 2)

I/O Standard	-6 Speed Grade		-7 Speed Grade		-8 Speed Grade		Unit
	Min	Max	Min	Max	Min	Max	
SSTL-2 class II		-278	—	-320	—	-362	ps
LVDS		-261	—	-301	—	-340	ps

Table 4–41. Cyclone I/O Standard Row Pin Input Delay Adders

I/O Standard	-6 Speed Grade		-7 Speed Grade		-8 Speed Grade		Unit
	Min	Max	Min	Max	Min	Max	
LVC MOS	—	0	—	0	—	0	ps
3.3-V LVTTTL	—	0	—	0	—	0	ps
2.5-V LVTTTL	—	27	—	31	—	35	ps
1.8-V LVTTTL	—	182	—	209	—	236	ps
1.5-V LVTTTL	—	278	—	319	—	361	ps
3.3-V PCI (1)	—	0	—	0	—	0	ps
SSTL-3 class I	—	-250	—	-288	—	-325	ps
SSTL-3 class II	—	-250	—	-288	—	-325	ps
SSTL-2 class I	—	-278	—	-320	—	-362	ps
SSTL-2 class II	—	-278	—	-320	—	-362	ps
LVDS	—	-261	—	-301	—	-340	ps

Table 4–42. Cyclone I/O Standard Output Delay Adders for Fast Slew Rate on Column Pins (Part 1 of 2)

Standard		-6 Speed Grade		-7 Speed Grade		-8 Speed Grade		Unit
		Min	Max	Min	Max	Min	Max	
LVC MOS	2 mA	—	0	—	0	—	0	ps
	4 mA	—	-489	—	-563	—	-636	ps
	8 mA	—	-855	—	-984	—	-1,112	ps
	12 mA	—	-993	—	-1,142	—	-1,291	ps
3.3-V LVTTTL	4 mA	—	0	—	0	—	0	ps
	8 mA	—	-347	—	-400	—	-452	ps
	12 mA	—	-858	—	-987	—	-1,116	ps
	16 mA	—	-819	—	-942	—	-1,065	ps
	24 mA	—	-993	—	-1,142	—	-1,291	ps

Table 4–42. Cyclone I/O Standard Output Delay Adders for Fast Slew Rate on Column Pins (Part 2 of 2)

Standard		-6 Speed Grade		-7 Speed Grade		-8 Speed Grade		Unit
		Min	Max	Min	Max	Min	Max	
2.5-V LVTTTL	2 mA	—	329	—	378	—	427	ps
	8 mA	—	-661	—	-761	—	-860	ps
	12 mA	—	-655	—	-754	—	-852	ps
	16 mA	—	-795	—	-915	—	-1034	ps
1.8-V LVTTTL	2 mA	—	4	—	4	—	5	ps
	8 mA	—	-208	—	-240	—	-271	ps
	12 mA	—	-208	—	-240	—	-271	ps
1.5-V LVTTTL	2 mA	—	2,288	—	2,631	—	2,974	ps
	4 mA	—	608	—	699	—	790	ps
	8 mA	—	292	—	335	—	379	ps
SSTL-3 class I		—	-410	—	-472	—	-533	ps
SSTL-3 class II		—	-811	—	-933	—	-1,055	ps
SSTL-2 class I		—	-485	—	-558	—	-631	ps
SSTL-2 class II		—	-758	—	-872	—	-986	ps
LVDS		—	-998	—	-1,148	—	-1,298	ps

Table 4–43. Cyclone I/O Standard Output Delay Adders for Fast Slew Rate on Row Pins (Part 1 of 2)

Standard		-6 Speed Grade		-7 Speed Grade		-8 Speed Grade		Unit
		Min	Max	Min	Max	Min	Max	
LVCMOS	2 mA	—	0	—	0	—	0	ps
	4 mA	—	-489	—	-563	—	-636	ps
	8 mA	—	-855	—	-984	—	-1,112	ps
	12 mA	—	-993	—	-1,142	—	-1,291	ps
3.3-V LVTTTL	4 mA	—	0	—	0	—	0	ps
	8 mA	—	-347	—	-400	—	-452	ps
	12 mA	—	-858	—	-987	—	-1,116	ps
	16 mA	—	-819	—	-942	—	-1,065	ps
	24 mA	—	-993	—	-1,142	—	-1,291	ps
2.5-V LVTTTL	2 mA	—	329	—	378	—	427	ps
	8 mA	—	-661	—	-761	—	-860	ps
	12 mA	—	-655	—	-754	—	-852	ps
	16 mA	—	-795	—	-915	—	-1,034	ps

Table 4–43. Cyclone I/O Standard Output Delay Adders for Fast Slew Rate on Row Pins (Part 2 of 2)

Standard		-6 Speed Grade		-7 Speed Grade		-8 Speed Grade		Unit
		Min	Max	Min	Max	Min	Max	
1.8-V LVTTTL	2 mA	—	1,290	—	1,483	—	1,677	ps
	8 mA	—	4	—	4	—	5	ps
	12 mA	—	-208	—	-240	—	-271	ps
1.5-V LVTTTL	2 mA	—	2,288	—	2,631	—	2,974	ps
	4 mA	—	608	—	699	—	790	ps
	8 mA	—	292	—	335	—	379	ps
3.3-V PCI (1)		—	-877	—	-1,009	—	-1,141	ps
SSTL-3 class I		—	-410	—	-472	—	-533	ps
SSTL-3 class II		—	-811	—	-933	—	-1,055	ps
SSTL-2 class I		—	-485	—	-558	—	-631	ps
SSTL-2 class II		—	-758	—	-872	—	-986	ps
LVDS		—	-998	—	-1,148	—	-1,298	ps

Table 4–44. Cyclone I/O Standard Output Delay Adders for Slow Slew Rate on Column Pins (Part 1 of 2)

I/O Standard		-6 Speed Grade		-7 Speed Grade		-8 Speed Grade		Unit
		Min	Max	Min	Max	Min	Max	
LVCMOS	2 mA	—	1,800	—	2,070	—	2,340	ps
	4 mA	—	1,311	—	1,507	—	1,704	ps
	8 mA	—	945	—	1,086	—	1,228	ps
	12 mA	—	807	—	928	—	1,049	ps
3.3-V LVTTTL	4 mA	—	1,831	—	2,105	—	2,380	ps
	8 mA	—	1,484	—	1,705	—	1,928	ps
	12 mA	—	973	—	1,118	—	1,264	ps
	16 mA	—	1,012	—	1,163	—	1,315	ps
	24 mA	—	838	—	963	—	1,089	ps
2.5-V LVTTTL	2 mA	—	2,747	—	3,158	—	3,570	ps
	8 mA	—	1,757	—	2,019	—	2,283	ps
	12 mA	—	1,763	—	2,026	—	2,291	ps
	16 mA	—	1,623	—	1,865	—	2,109	ps
1.8-V LVTTTL	2 mA	—	5,506	—	6,331	—	7,157	ps
	8 mA	—	4,220	—	4,852	—	5,485	ps
	12 mA	—	4,008	—	4,608	—	5,209	ps

Table 4–44. Cyclone I/O Standard Output Delay Adders for Slow Slew Rate on Column Pins (Part 2 of 2)

I/O Standard		-6 Speed Grade		-7 Speed Grade		-8 Speed Grade		Unit
		Min	Max	Min	Max	Min	Max	
1.5-V LVTTTL	2 mA	—	6,789	—	7,807	—	8,825	ps
	4 mA	—	5,109	—	5,875	—	6,641	ps
	8 mA	—	4,793	—	5,511	—	6,230	ps
SSTL-3 class I		—	1,390	—	1,598	—	1,807	ps
SSTL-3 class II		—	989	—	1,137	—	1,285	ps
SSTL-2 class I		—	1,965	—	2,259	—	2,554	ps
SSTL-2 class II		—	1,692	—	1,945	—	2,199	ps
LVDS		—	802	—	922	—	1,042	ps

Table 4–45. Cyclone I/O Standard Output Delay Adders for Slow Slew Rate on Row Pins (Part 1 of 2)

I/O Standard		-6 Speed Grade		-7 Speed Grade		-8 Speed Grade		Unit
		Min	Max	Min	Max	Min	Max	
LVCMOS	2 mA	—	1,800	—	2,070	—	2,340	ps
	4 mA	—	1,311	—	1,507	—	1,704	ps
	8 mA	—	945	—	1,086	—	1,228	ps
	12 mA	—	807	—	928	—	1,049	ps
3.3-V LVTTTL	4 mA	—	1,831	—	2,105	—	2,380	ps
	8 mA	—	1,484	—	1,705	—	1,928	ps
	12 mA	—	973	—	1,118	—	1,264	ps
	16 mA	—	1,012	—	1,163	—	1,315	ps
	24 mA	—	838	—	963	—	1,089	ps
2.5-V LVTTTL	2 mA	—	2,747	—	3,158	—	3,570	ps
	8 mA	—	1,757	—	2,019	—	2,283	ps
	12 mA	—	1,763	—	2,026	—	2,291	ps
	16 mA	—	1,623	—	1,865	—	2,109	ps
1.8-V LVTTTL	2 mA	—	5,506	—	6,331	—	7,157	ps
	8 mA	—	4,220	—	4,852	—	5,485	ps
	12 mA	—	4,008	—	4,608	—	5,209	ps
1.5-V LVTTTL	2 mA	—	6,789	—	7,807	—	8,825	ps
	4 mA	—	5,109	—	5,875	—	6,641	ps
	8 mA	—	4,793	—	5,511	—	6,230	ps
3.3-V PCI		—	923	—	1,061	—	1,199	ps

Table 4–45. Cyclone I/O Standard Output Delay Adders for Slow Slew Rate on Row Pins (Part 2 of 2)

I/O Standard	-6 Speed Grade		-7 Speed Grade		-8 Speed Grade		Unit
	Min	Max	Min	Max	Min	Max	
SSTL-3 class I	—	1,390	—	1,598	—	1,807	ps
SSTL-3 class II	—	989	—	1,137	—	1,285	ps
SSTL-2 class I	—	1,965	—	2,259	—	2,554	ps
SSTL-2 class II	—	1,692	—	1,945	—	2,199	ps
LVDS	—	802	—	922	—	1,042	ps

Note to [Tables 4–40 through 4–45](#):

- (1) EP1C3 devices do not support the PCI I/O standard.

[Tables 4–46 through 4–47](#) show the adder delays for the IOE programmable delays. These delays are controlled with the Quartus II software options listed in the Parameter column.

Table 4–46. Cyclone IOE Programmable Delays on Column Pins

Parameter	Setting	-6 Speed Grade		-7 Speed Grade		-8 Speed Grade		Unit
		Min	Max	Min	Max	Min	Max	
Decrease input delay to internal cells	Off	—	155	—	178	—	201	ps
	Small	—	2,122	—	2,543	—	2,875	ps
	Medium	—	2,639	—	3,034	—	3,430	ps
	Large	—	3,057	—	3,515	—	3,974	ps
	On	—	155	—	178	—	201	ps
Decrease input delay to input register	Off	—	0	—	0	—	0	ps
	On	—	3,057	—	3,515	—	3,974	ps
Increase delay to output pin	Off	—	0	—	0	—	0	ps
	On	—	552	—	634	—	717	ps

Table 4–47. Cyclone IOE Programmable Delays on Row Pins

Parameter	Setting	-6 Speed Grade		-7 Speed Grade		-8 Speed Grade		Unit
		Min	Max	Min	Max	Min	Max	
Decrease input delay to internal cells	Off	—	154	—	177	—	200	ps
	Small	—	2,212	—	2,543	—	2,875	ps
	Medium	—	2,639	—	3,034	—	3,430	ps
	Large	—	3,057	—	3,515	—	3,974	ps
	On	—	154	—	177	—	200	ps
Decrease input delay to input register	Off	—	0	—	0	—	0	ps
	On	—	3,057	—	3,515	—	3,974	ps
Increase delay to output pin	Off	—	0	—	0	—	0	ps
	On	—	556	—	639	—	722	ps

Note to [Table 4–47](#):

- (1) EPC1C3 devices do not support the PCI I/O standard.

Maximum Input and Output Clock Rates

[Tables 4–48](#) and [4–49](#) show the maximum input clock rate for column and row pins in Cyclone devices.

Table 4–48. Cyclone Maximum Input Clock Rate for Column Pins

I/O Standard	-6 Speed Grade	-7 Speed Grade	-8 Speed Grade	Unit
LVTTTL	464	428	387	MHz
2.5 V	392	302	207	MHz
1.8 V	387	311	252	MHz
1.5 V	387	320	243	MHz
LVC MOS	405	374	333	MHz
SSTL-3 class I	405	356	293	MHz
SSTL-3 class II	414	365	302	MHz
SSTL-2 class I	464	428	396	MHz
SSTL-2 class II	473	432	396	MHz
LVDS	567	549	531	MHz

Table 4–49. Cyclone Maximum Input Clock Rate for Row Pins

I/O Standard	-6 Speed Grade	-7 Speed Grade	-8 Speed Grade	Unit
LVTTTL	464	428	387	MHz
2.5 V	392	302	207	MHz
1.8 V	387	311	252	MHz
1.5 V	387	320	243	MHz
LVC MOS	405	374	333	MHz
SSTL-3 class I	405	356	293	MHz
SSTL-3 class II	414	365	302	MHz
SSTL-2 class I	464	428	396	MHz
SSTL-2 class II	473	432	396	MHz
3.3-V PCI (1)	464	428	387	MHz
LVDS	567	549	531	MHz

Note to Tables 4–48 through 4–49:

- (1) EP1C3 devices do not support the PCI I/O standard. These parameters are only available on row I/O pins.

Tables 4–50 and 4–51 show the maximum output clock rate for column and row pins in Cyclone devices.

Table 4–50. Cyclone Maximum Output Clock Rate for Column Pins

I/O Standard	-6 Speed Grade	-7 Speed Grade	-8 Speed Grade	Unit
LVTTTL	304	304	304	MHz
2.5 V	220	220	220	MHz
1.8 V	213	213	213	MHz
1.5 V	166	166	166	MHz
LVC MOS	304	304	304	MHz
SSTL-3 class I	100	100	100	MHz
SSTL-3 class II	100	100	100	MHz
SSTL-2 class I	134	134	134	MHz
SSTL-2 class II	134	134	134	MHz
LVDS	320	320	275	MHz

Note to Table 4–50:

- (1) EP1C3 devices do not support the PCI I/O standard.

Table 4–51. Cyclone Maximum Output Clock Rate for Row Pins

I/O Standard	-6 Speed Grade	-7 Speed Grade	-8 Speed Grade	Unit
LVTTTL	296	285	273	MHz
2.5 V	381	366	349	MHz
1.8 V	286	277	267	MHz
1.5 V	219	208	195	MHz
LVC MOS	367	356	343	MHz
SSTL-3 class I	169	166	162	MHz
SSTL-3 class II	160	151	146	MHz
SSTL-2 class I	160	151	142	MHz
SSTL-2 class II	131	123	115	MHz
3.3-V PCI (1)	66	66	66	MHz
LVDS	320	303	275	MHz

Note to Tables 4–50 through 4–51:

- (1) EP1C3 devices do not support the PCI I/O standard. These parameters are only available on row I/O pins.

PLL Timing

Table 4–52 describes the Cyclone FPGA PLL specifications.

Table 4–52. Cyclone PLL Specifications (Part 1 of 2)

Symbol	Parameter	Min	Max	Unit
f_{IN}	Input frequency (-6 speed grade)	15.625	464	MHz
	Input frequency (-7 speed grade)	15.625	428	MHz
	Input frequency (-8 speed grade)	15.625	387	MHz
f_{IN} DUTY	Input clock duty cycle	40.00	60	%
t_{IN} JITTER	Input clock period jitter	—	± 200	ps
f_{OUT_EXT} (external PLL clock output)	PLL output frequency (-6 speed grade)	15.625	320	MHz
	PLL output frequency (-7 speed grade)	15.625	320	MHz
	PLL output frequency (-8 speed grade)	15.625	275	MHz

Table 4–52. Cyclone PLL Specifications (Part 2 of 2)

Symbol	Parameter	Min	Max	Unit
f_{OUT} (to global clock)	PLL output frequency (-6 speed grade)	15.625	405	MHz
	PLL output frequency (-7 speed grade)	15.625	320	MHz
	PLL output frequency (-8 speed grade)	15.625	275	MHz
$t_{OUT DUTY}$	Duty cycle for external clock output (when set to 50%)	45.00	55	%
t_{JITTER} (1)	Period jitter for external clock output	—	±300 (2)	ps
t_{LOCK} (3)	Time required to lock from end of device configuration	10.00	100	μs
f_{VCO}	PLL internal VCO operating range	500.00	1,000	MHz
-	Minimum areset time	10	—	ns
N, G0, G1, E	Counter values	1	32	integer

Notes to Table 4–52:

- (1) The t_{JITTER} specification for the PLL[2..1]_OUT pins are dependent on the I/O pins in its V_{CCIO} bank, how many of them are switching outputs, how much they toggle, and whether or not they use programmable current strength or slow slew rate.
- (2) $f_{OUT} \geq 100$ MHz. When the PLL external clock output frequency (f_{OUT}) is smaller than 100 MHz, the jitter specification is 60 mUI.
- (3) $f_{IN/N}$ must be greater than 200 MHz to ensure correct lock detect circuit operation below -20 C. Otherwise, the PLL operates with the specified parameters under the specified conditions.

Referenced Document

This chapter references the following documents:

- *Cyclone Architecture* chapter in the *Cyclone Device Handbook*
- *Operating Requirements for Altera Devices Data Sheet*

Document Revision History

Table 4-53 shows the revision history for this chapter.

Date and Document Version	Changes Made	Summary of Changes
May 2008 v1.7	Minor textual and style changes. Added “Referenced Document” section.	—
January 2007 v1.6	<ul style="list-style-type: none"> ● Added document revision history. ● Added new row for V_{CCA} details in Table 4-1. ● Updated R_{CONF} information in Table 4-3. ● Added new <i>Note (12)</i> on voltage overdrive information to Table 4-7 and Table 4-8. ● Updated <i>Note (9)</i> on R_{CONF} information to Table 4-3. ● Updated information in “External I/O Delay Parameters” section. ● Updated speed grade information in Table 4-46 and Table 4-47. ● Updated LVDS information in Table 4-51. 	—
August 2005 v1.5	Minor updates.	—
February 2005 v1.4	<ul style="list-style-type: none"> ● Updated information on Undershoot voltage. Updated Table 4-2. ● Updated Table 4-3. ● Updated the undershoot voltage from 0.5 V to 2.0 V in Note 3 of Table 4-16. ● Updated Table 4-17. 	—
January 2004 v.1.3	<ul style="list-style-type: none"> ● Added extended-temperature grade device information. Updated Table 4-2. ● Updated I_{CC0} information in Table 4-3. 	—
October 2003 v.1.2	<ul style="list-style-type: none"> ● Added clock tree information in Table 4-19. ● Finalized timing information for EP1C3 and EP1C12 devices. Updated timing information in Tables 4-25 through 4-26 and Tables 4-30 through 4-51. ● Updated PLL specifications in Table 4-52. 	—

July 2003 v1.1	Updated timing information. Timing finalized for EP1C6 and EP1C20 devices. Updated performance information. Added PLL Timing section.	—
May 2003 v1.0	Added document to Cyclone Device Handbook.	—