

Introduction

The Cyclone® FPGA family provides the best solution for high-volume, cost-sensitive applications. A Cyclone device is fabricated on a leading-edge 1.5-V, 0.13- μm , all-layer copper SRAM process.

Using a 1.5-V operating voltage provides the following advantages:

- Lower power consumption compared to 2.5-V or 3.3-V devices.
- Lower operating temperature.
- Less need for fans and other temperature-control elements.

Since many existing designs are based on 5.0-V, 3.3-V and 2.5-V power supplies, a voltage regulator may be required to lower the voltage supply level to 1.5-V. This document provides guidelines for designing with Cyclone devices in mixed-voltage and single-voltage systems and provides examples using voltage regulators. This document also includes information about:

- [“Power Sequencing and Hot Socketing” on page 12-1](#)
- [“Using MultiVolt I/O Pins” on page 12-2](#)
- [“Voltage Regulators” on page 12-3](#)
- [“1.5-V Regulator Application Examples” on page 12-19](#)
- [“Board Layout” on page 12-21](#)
- [“Power Sequencing and Hot Socketing” on page 12-1](#)

Power Sequencing and Hot Socketing

Because 1.5-V Cyclone FPGAs can be used in a mixed-voltage environment, they have been designed specifically to tolerate any possible power-up sequence. Therefore, the V_{CCIO} and V_{CCINT} power supplies may be powered in any order.

You can drive signals into Cyclone FPGAs before and during power up without damaging the device. In addition, Cyclone FPGAs do not drive out during power up since they are tri-stated during power up. Once the device reaches operating conditions and is configured, Cyclone FPGAs operate as specified by the user.



For more information, refer to the [Cyclone FPGA Family Data Sheet](#) section of the *Cyclone Device Handbook*.

Using MultiVolt I/O Pins

Cyclone FPGAs require a 1.5-V V_{CCINT} and a 3.3-V, 2.5-V, 1.8-V, or 1.5-V I/O supply voltage level (V_{CCIO}). All pins, including dedicated inputs, clock, I/O, and JTAG pins, are 3.3-V tolerant before and after V_{CCINT} and V_{CCIO} are powered.

When V_{CCIO} is connected to 1.5-V, the output is compatible with 1.5-V logic levels. The output pins can be made 1.8-V, 2.5-V, or 3.3-V compatible by using open-drain outputs pulled up with external resistors. You can use external resistors to pull open-drain outputs up with a 1.8-V, 2.5-V, or 3.3-V V_{CCIO} . Table 12-1 summarizes Cyclone MultiVolt I/O support.

Table 12-1. Cyclone MultiVolt I/O Support Note (1)

V_{CCIO} (V)	Input Signal					Output Signal				
	1.5-V	1.8-V	2.5-V	3.3-V	5.0-V	1.5-V	1.8-V	2.5-V	3.3-V	5.0-V
1.5-V	✓	✓	✓ (2)	✓ (2)	—	✓	—	—	—	—
1.8-V	✓	✓	✓	✓	—	✓ (3)	✓	—	—	—
2.5-V	—	—	✓	✓	—	✓ (5)	✓ (5)	✓	—	—
3.3-V	—	—	✓ (4)	✓	✓ (6)	✓ (7)	✓ (7)	✓ (7)	✓	✓ (8)

Notes to Table 12-1:

- (1) The PCI clamping diode must be disabled to drive an input with voltages higher than V_{CCIO} .
- (2) When $V_{CCIO} = 1.5\text{-V}$ and a 2.5-V or 3.3-V input signal feeds an input pin, higher pin leakage current is expected.
- (3) When $V_{CCIO} = 1.8\text{-V}$, a Cyclone device can drive a 1.5-V device with 1.8-V tolerant inputs.
- (4) When $V_{CCIO} = 3.3\text{-V}$ and a 2.5-V input signal feeds an input pin, or when $V_{CCIO} = 1.8\text{-V}$ and a 1.5-V input signal feeds an input pin, the V_{CCIO} supply current is slightly larger than expected. The reason for this increase is that the input signal level does not drive to the V_{CCIO} rail, which causes the input buffer to not completely shut off.
- (5) When $V_{CCIO} = 2.5\text{-V}$, a Cyclone device can drive a 1.5-V or 1.8-V device with 2.5-V tolerant inputs.
- (6) Cyclone devices can be 5.0-V tolerant with the use of an external resistor and the internal PCI clamp diode.
- (7) When $V_{CCIO} = 3.3\text{-V}$, a Cyclone device can drive a 1.5-V, 1.8-V, or 2.5-V device with 3.3-V tolerant inputs.
- (8) When $V_{CCIO} = 3.3\text{-V}$, a Cyclone device can drive a device with 5.0-V LVTTTL inputs but not 5.0-V LVCMOS inputs.

Figure 12-1 shows how Cyclone FPGAs interface with 3.3-V and 2.5-V devices while operating with a 1.5-V V_{CCINT} to increase performance and save power.

Table 12–2. Voltage Regulator Specifications and Terminology (Part 2 of 2)

Specification/Terminology	Description
Load regulation (load regulation, V_{OUT})	Load regulation is a variation in the output voltage caused by changes in the input supply current. Linear Technology regulators are designed to minimize load regulation, which is affected by error amplifier gain, pass transistor gain, and output impedance.
Output voltage selection	Output voltage selection is adjustable by resistor voltage divider networks, connected to the error amplifier input, that control the output voltage. There are multiple output regulators that create 5.0-, 3.3-, 2.5-, 1.8- and 1.5-V supplies.
Quiescent current	Quiescent current is the supply current during no-load or quiescent state. This current is sometimes used as a general term for a supply current used by the regulator.
Dropout voltage	Dropout voltage is the difference between the input and output voltages when the input is low enough to cause the output to drop out of regulation. The dropout voltage should be as low as possible for better efficiency.
Current limiting	Voltage regulators are designed to limit the amount of output current in the event of a failing load. A short in the load causes the output current and voltage to decrease. This event cuts power dissipation in the regulator during a short circuit.
Thermal overload protection	This feature limits power dissipation if the regulator overheats. When a specified temperature is reached, the regulator turns off the output drive transistors, allowing the regulator to cool. Normal operation resumes once the regulator reaches a normal operating temperature.
Reverse current protection	If the input power supply fails, large output capacitors can cause a substantial reverse current to flow backward through the regulator, potentially causing damage. To prevent damage, protection diodes in the regulator create a path for the current to flow from V_{OUT} to V_{IN} .
Stability	The dominant pole placed by the output capacitor influences stability. Voltage regulator vendors can assist you in output capacitor selection for regulator designs that differ from what is offered.
Minimum load requirements	A minimum load from the voltage divider network is required for good regulation, which also serves as the ground for the regulator's current path.
Efficiency	Efficiency is the division of the output power by the input power. Each regulator model has a specific efficiency value. The higher the efficiency value, the better the regulator.

Linear Voltage Regulators

Linear voltage regulators generate a regulated output from a larger input voltage using current pass elements in a linear mode. There are two types of linear regulators available: one using a series pass element and another using a shunt element (e.g., a zener diode). Altera recommends using series linear regulators because shunt regulators are less efficient.

Series linear regulators use a series pass element (i.e., a bipolar transistor or MOSFET) controlled by a feedback error amplifier (see [Figure 12–2](#)) to regulate the output voltage by comparing the output to a reference voltage. The error amplifier drives the transistor further on or off continuously to control the flow of current needed to sustain a steady voltage level across the load.

Figure 12–2. Series Linear Regulator

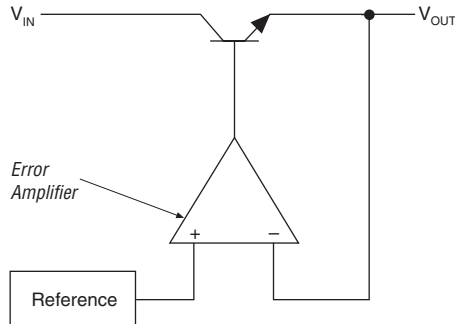

[Table 12–3](#) shows the advantages and disadvantages of linear regulators compared to switching regulators.

Advantages	Disadvantages
Requires few supporting components Low cost Requires less board space Quick transient response Better noise and drift characteristics No electromagnetic interference (EMI) radiation from the switching components Tighter regulation	Less efficient (typically 60%) Higher power dissipation Larger heat sink requirements

You can minimize the difference between the input and output voltages to improve the efficiency of linear regulators. The dropout voltage is the minimum allowable difference between the regulator’s input and output voltage.

Linear regulators are available with fixed, variable, single, or multiple outputs. Multiple-output regulators can generate multiple outputs (e.g., 1.5- and 3.3-V outputs). If the board only has a 5.0-V power voltage supply, you should use multiple-output regulators. The logic array requires a 1.5-V power supply, and a 3.3-V power supply is required to interface with 3.3- and 5.0-V devices. However, fixed-output regulators have fewer supporting components, reducing board space and cost. Figure 12-3 shows an example of a three-terminal, fixed-output linear regulator.

Figure 12-3. Three-Terminal, Fixed-Output Linear Regulator

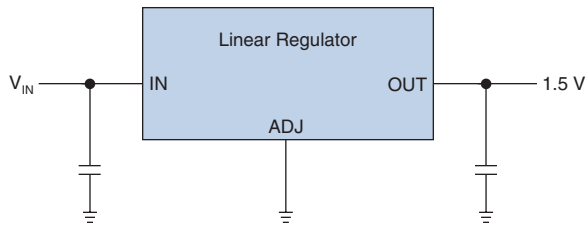

Adjustable-output regulators contain a voltage divider network that controls the regulator's output. Figure 12-4 shows how you can also use a three-terminal linear regulator in an adjustable-output configuration.

Figure 12-4. Adjustable-Output Linear Regulator

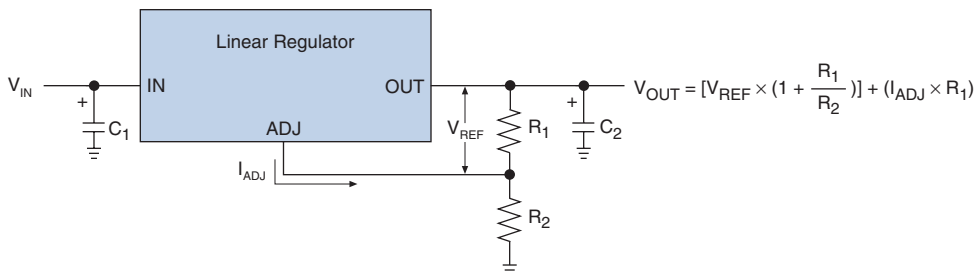

Switching Voltage Regulators

Step-down switching regulators can provide 3.3-V-to-1.5-V conversion with up to 95% efficiencies. This high efficiency comes from minimizing quiescent current, using a low-resistance power MOSFET switch, and, in higher-current applications, using a synchronous switch to reduce diode losses.

Switching regulators supply power by pulsing the output voltage and current to the load. Table 12-4 shows the advantages and disadvantages of switching regulators compared to linear regulators.



For more information about switching regulators, refer to Linear Technology's application note, *AN35: Step Down Switching Regulators*, at www.linear.com/designtools/app_notes.jsp.

Advantages	Disadvantages
Highly efficient (typically >80%) Reduced power dissipation Smaller heat sink requirements Wider input voltage range High power density	Generates EMI Complex to design Requires 15 or more supporting components Higher cost Requires more board space

There are two types of switching regulators, asynchronous and synchronous. Asynchronous switching regulators have one field effect transistor (FET) and a diode to provide the current path while the FET is off (see Figure 12-5).

Figure 12-5. Asynchronous Switching Regulator

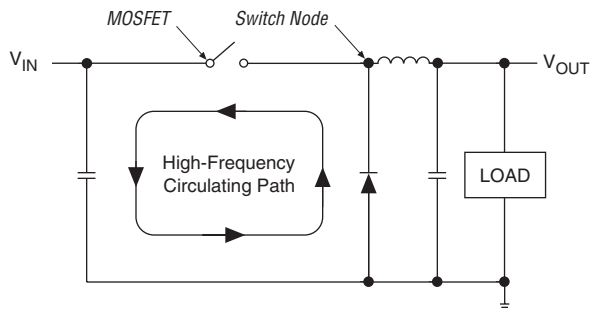

Synchronous switching regulators have a voltage- or current-controlled oscillator that controls the on and off time of the two MOSFET devices that supply the current to the circuit (see Figure 12-6).

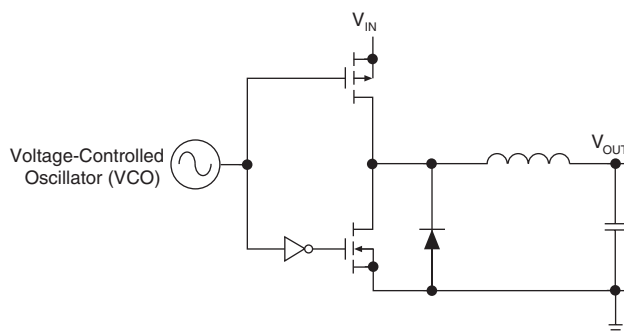
Figure 12–6. Voltage-Controlled Synchronous Switching Regulator

Maximum Output Current

Select an external MOSFET switching transistor (optional) based on the maximum output current that it can supply. Use a MOSFET with a low on-resistance and a voltage rating high enough to avoid avalanche breakdown. For gate-drive voltages less than 9-V, use a logic-level MOSFET. A logic-level MOSFET is only required for topologies with a controller IC and an external MOSFET.

Selecting Voltage Regulators

Your design requirements determine which voltage regulator you need. The key to selecting a voltage regulator is understanding the regulator parameters and how they relate to the design.

The following checklist can help you select the proper regulator for your design:

- Do you require a 3.3-V, 2.5-V, and 1.5-V output (V_{OUT})?
- What precision is required on the regulated 1.5-V supplies (line and load regulation)?
- What supply voltages (V_{IN} or V_{CC}) are available on the board?
- What voltage variance (input voltage range) is expected on V_{IN} or V_{CC} ?
- What is the maximum I_{CC} (I_{OUT}) required by your Altera® device?
- What is the maximum current surge ($I_{OUT(MAX)}$) that the regulator will need to supply instantaneously?

Choose a Regulator Type

If required, select either a linear, asynchronous switching, or synchronous switching regulator based on your output current, regulator efficiency, cost, and board-space requirements. DC-to-DC converters have output current capabilities from 1 to 8 A. You can use a controller with an external MOSFET rated for higher current for higher-output-current applications.

Calculate the Maximum Input Current

Use the following equation to estimate the maximum input current based on the output power requirements at the maximum input voltage:

$$I_{IN,DC(MAX)} = \frac{V_{OUT} \times I_{OUT(MAX)}}{\eta \times V_{IN(MAX)}}$$

Where η is nominal efficiency: typically 90% for switching regulators, 60% for linear 2.5-V-to-1.5-V conversion, 45% for linear 3.3-V-to-1.5-V conversion, and 30% for linear 5.0-V-to-1.5-V conversion.

Once you identify the design requirements, select the voltage regulator that is best for your design. Tables 12-5 and 12-6 list a few Linear Technology and Elantec regulators available at the time this document was published. There may be more regulators to choose from depending on your design specification. Contact a regulator manufacturer for availability.

Table 12-5. Linear Technology 1.5-V Output Voltage Regulators

Voltage Regulator	Regulator Type	Total Number of Components	V _{IN} (V)	I _{OUT} (A)	Special Features
LT1573	Linear	10	2.5 or 3.3 (1)	6	—
LT1083	Linear	5	5.0	7.5	—
LT1084	Linear	5	5.0	5	—
LT1085	Linear	5	5.0	3	Inexpensive solution
LTC1649	Switching	22	3.3	15	Selectable output
LTC1775	Switching	17	5.0	5	—

Note to Table 12-5:

- (1) A 3.3-V V_{IN} requires a 3.3-V supply to the regulator's input and 2.5-V supply to bias the transistors.

Table 12–6. Elantec 1.5-V Output Voltage Regulators

Voltage Regulator	Regulator Type	Total Number of Components	V _{IN} (V)	I _{OUT} (A)	Special Features
EL7551C	Switching	11	5.0	1	—
EL7564CM	Switching	13	5.0	4	—
EL7556BC	Switching	21	5.0	6	—
EL7562CM	Switching	17	3.3 or 5.5	2	—
EL7563CM	Switching	19	3.3	4	—

Voltage Divider Network

Design a voltage divider network if you are using an adjustable output regulator. Follow the controller or converter IC's instructions to adjust the output voltage.

1.5-V Regulator Circuits

This section contains the circuit diagrams for the voltage regulators discussed in this chapter. You can use the voltage regulators in this section to generate a 1.5-V power supply. Refer to the voltage regulator data sheet to find detailed specifications. If you require further information that is not shown in the data sheet, contact the regulator's vendor.

Figures 12–7 through 12–12 show the circuit diagrams of Linear Technology voltage regulators listed in Table 12–5.

The LT1573 linear voltage regulator converts 2.5-V to 1.5-V with an output current of 6A (see Figure 12–7).

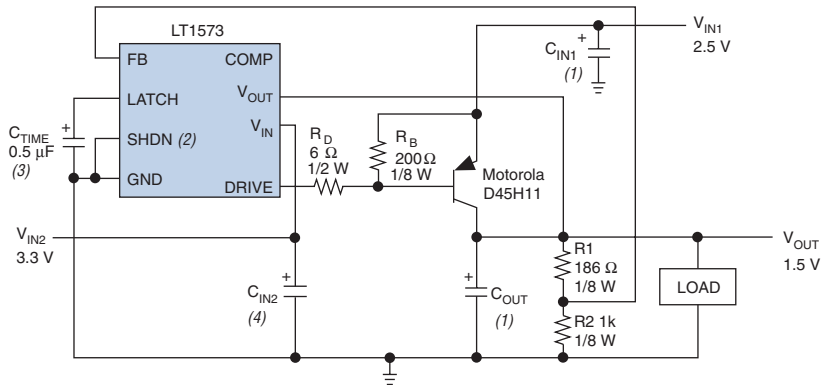
Figure 12-7. LT1573: 2.5-V-to-1.5-V/6.0-A Linear Voltage Regulator**Notes to Figure 12-7:**

- (1) C_{IN1} and C_{OUT} are AVX 100- μ F/10-V surface-mount tantalum capacitors.
- (2) Use SHDN (active high) to shut down the regulator.
- (3) C_{TIME} is a 0.5- μ F capacitor for 100-ms time out at room temperature.
- (4) C_{IN2} is an AVX 15- μ F/10-V surface-mount tantalum capacitor.

Use adjustable 5.0- to 1.5-V regulators (shown in Figures 12-8 through 12-10) for 3.0- to 7.5-A low-cost, low-device-count, board-space-efficient solutions.

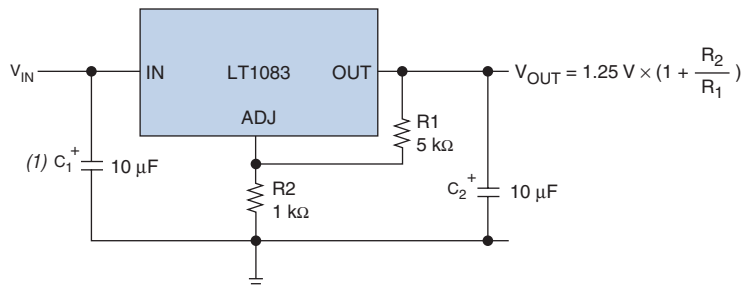
Figure 12-8. LT1083: 5.0-V-to-1.5-V/7.5-A Linear Voltage Regulator**Note to Figure 12-8:**

- (1) This capacitor is necessary to maintain the voltage level at the input regulator. There could be a voltage drop at the input if the voltage supply is too far away.

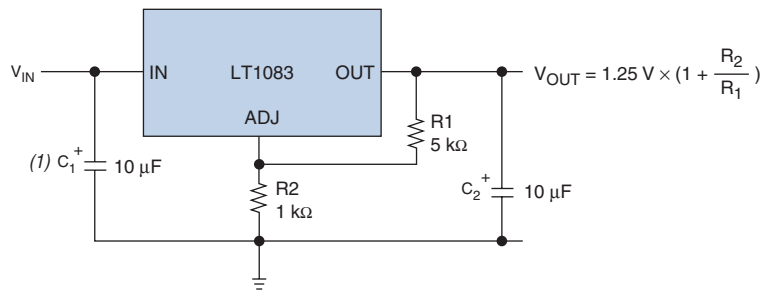
Figure 12–9. LT1084: 5.0-V-to-1.5-V/5.0-A Linear Voltage Regulator**Note to Figure 12–9:**

- (1) This capacitor is necessary to maintain the voltage level at the input regulator. There could be a voltage drop at the input if the voltage supply is too far away.

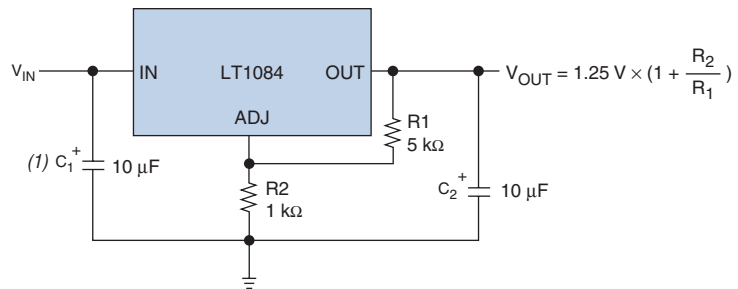
Figure 12–10. LT1085: 5.0-V-to-1.5-V/3-A Linear Voltage Regulator**Note to Figure 12–10:**

- (1) This capacitor is necessary to maintain the voltage level at the input regulator. There could be a voltage drop at the input if the voltage supply is too far away.

Figure 12–11 shows a high-efficiency switching regulator circuit diagram. A selectable resistor network controls the output voltage. The resistor values in Figure 12–11 are selected for 1.5-V output operation.

Figure 12–11. LT1649: 3.3-V-to-1.5-V/15-A Asynchronous Switching Regulator

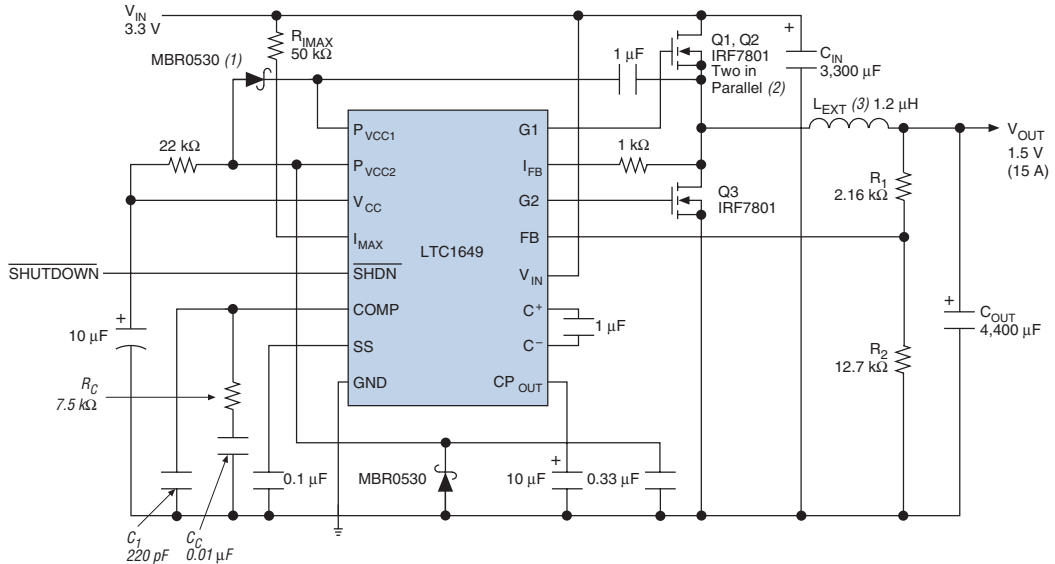

Notes to Figure 12–11:

- (1) MBR0530 is a Motorola device.
- (2) IRF7801 is a International Rectifier device.
- (3) Refer to the Panasonic 12TS-1R2HL device.

Figure 12–12 shows synchronous switching regulator with adjustable outputs.

Figure 12–12. LTC1775: 5.0-V-to-1.5-V/5-A Synchronous Switching Regulator

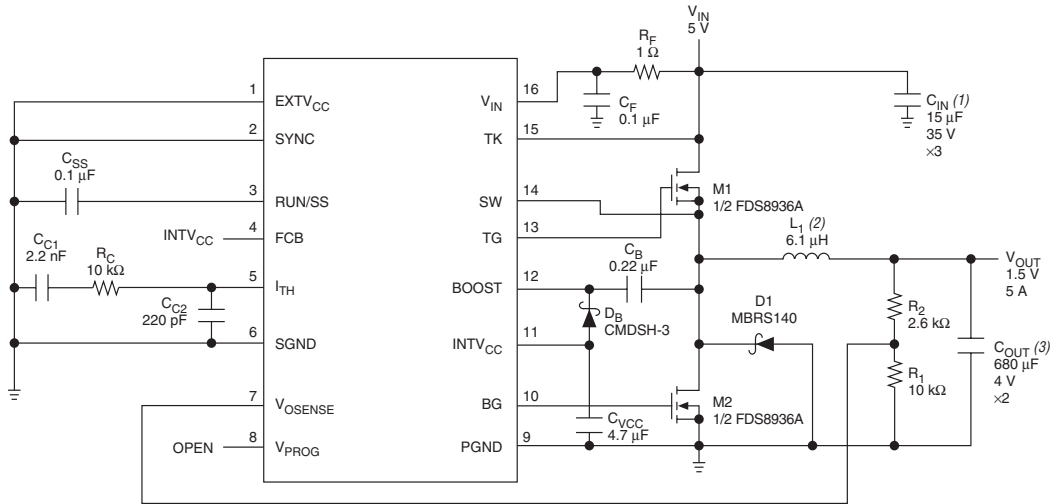

Notes to Figure 12–12:

- (1) This is a KEMETT495X156M035AS capacitor.
- (2) This is a Sumida CDRH127-6R1 inductor.
- (3) This is a KEMETT510X687K004AS capacitor.

Figures 12-13 through 12-17 show the circuit diagrams of Elantec voltage regulators listed in Table 12-6.

Figures 12-13 through 12-15 show the switching regulator that converts 5.0-V to 1.5-V with different output current.

Figure 12-13. EL7551C: 5.0-V-to-1.5-V/1-A Synchronous Switching Regulator

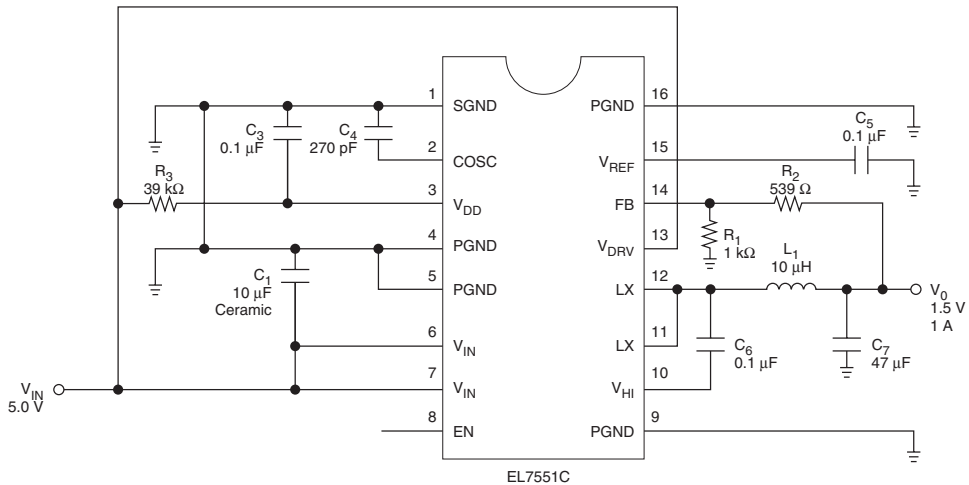

Figure 12-14. EL7564CM: 5.0-V-to-1.5-V/4-A Synchronous Switching Regulator

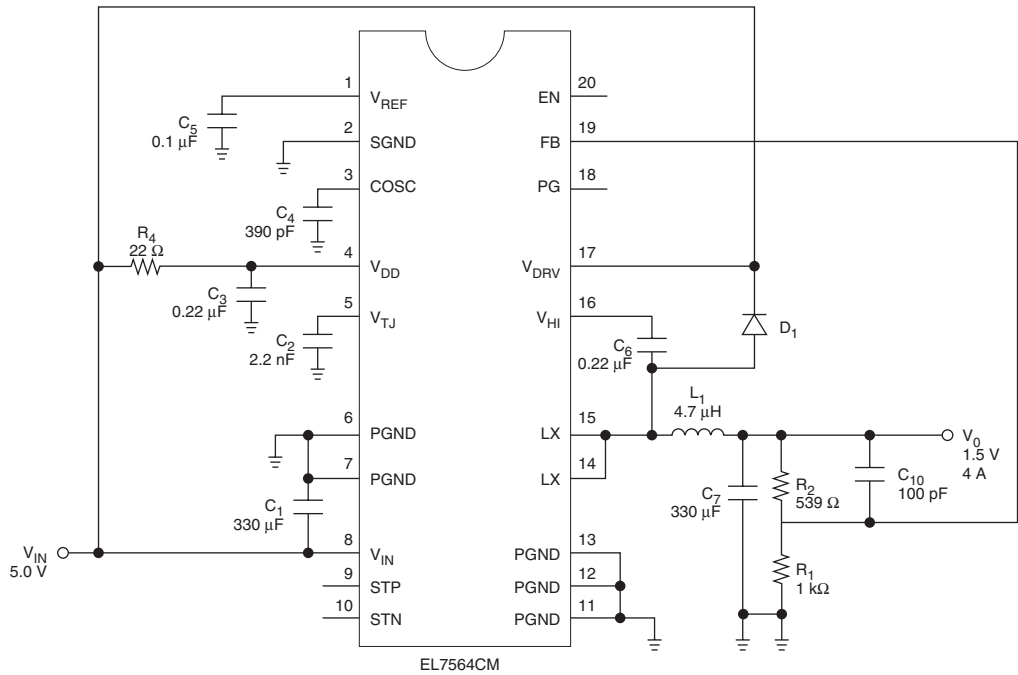
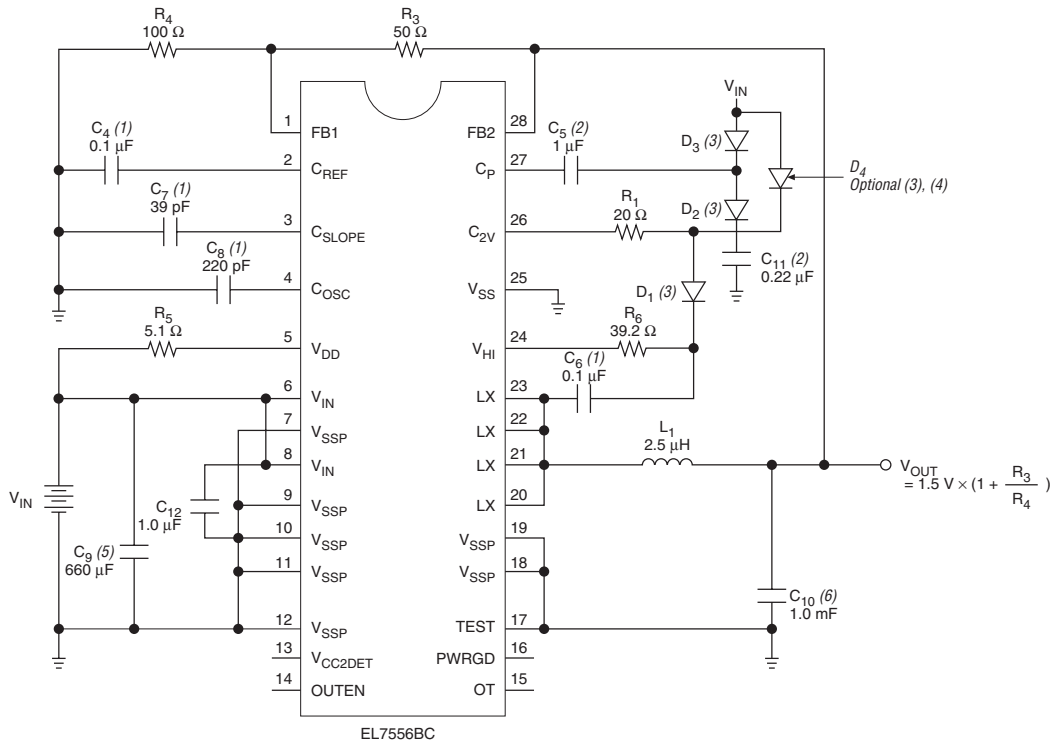

Figure 12–15. EL7556BC: 5.0-V-to-1.5-V/6-A Synchronous Switching Regulator



Notes to Figures 12–13 –12–15:

- (1) These capacitors are ceramic capacitors.
- (2) These capacitors are ceramic or tantalum capacitor.
- (3) These are BAT54S fast diodes.
- (4) D4 is only required for EL7556ACM.
- (5) This is a Sprague 293D337X96R3 2X330μF capacitor.
- (6) This is a Sprague 293D337X96R3 3X330μF capacitor.

Figures 12-16 and 12-17 show the switching regulator that converts 3.3 V to 1.5 V with different output currents.

Figure 12-16. EL7562CM: 3.3-V to 1.5-V/2-A Synchronous Switching Regulator

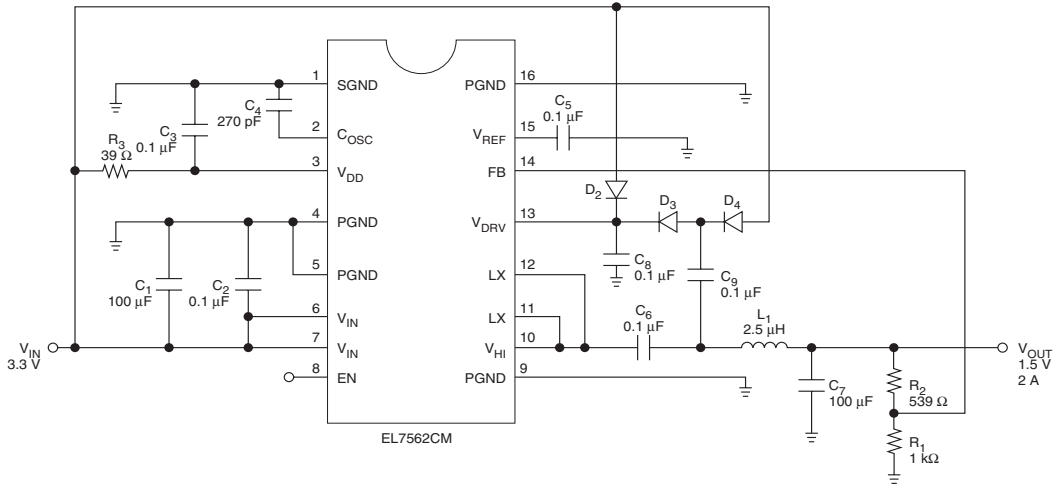
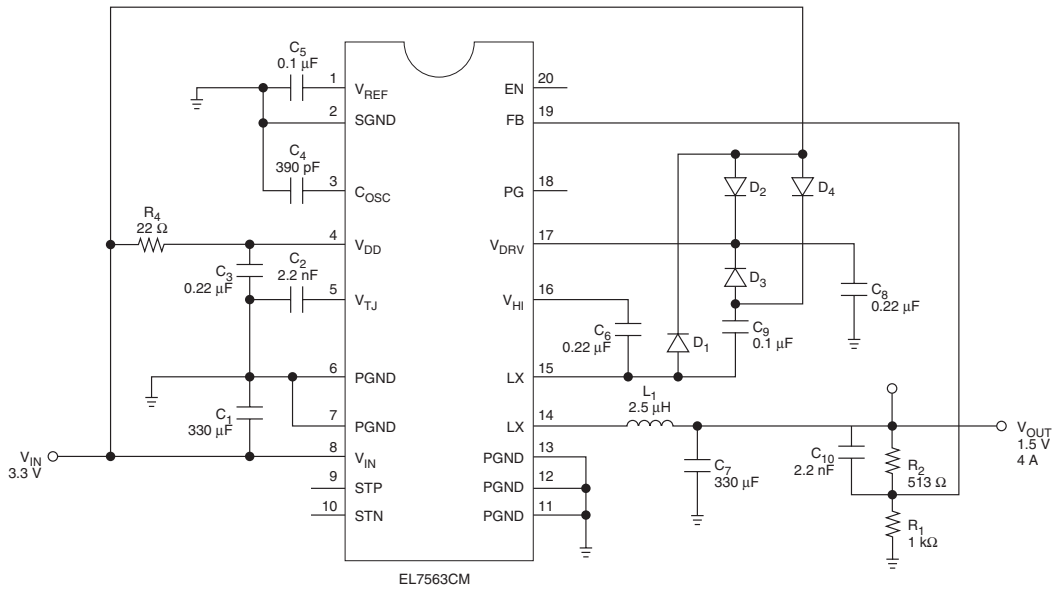

Figure 12-17. EL7563CM: 3.3-V to 1.5-V/4-A Synchronous Switching Regulator



1.5-V Regulator Application Examples

The following sections show the process used to select a voltage regulator for three sample designs. The regulator selection is based on the amount of power that the Cyclone device consumes. There are 14 variables to consider when selecting a voltage regulator. The following variables apply to Cyclone device power consumption:

- f_{MAX}
- Output and bidirectional pins
- Average toggle rate for I/O pins (to_{gIO})
- Average toggle rate for logic elements (LEs) (to_{gLC})
- User-mode I_{CC} consumption
- Maximum power-up I_{CCINT} requirement
- Utilization
- V_{CCIO} supply level
- V_{CCINT} supply level

The following variables apply to the voltage regulator:

- Output voltage precision requirement
- Supply voltage on the board
- Voltage supply output current
- Variance of board supply
- Efficiency

Different designs have different power consumptions based on the variables listed. Once you calculate the Cyclone device's power consumption, you must consider how much current the Cyclone device needs. You can use the Cyclone power calculator (available at www.altera.com) or the PowerGauge™ tool in the Quartus II software to determine the current needs. Also check the maximum power-up current requirement listed in the Power Consumption section of the Cyclone FPGA Family Data Sheet because the power-up current requirement may exceed the user-mode current consumption for a specific design.

Once you determine the minimum current the Cyclone device requires, you must select a voltage regulator that can generate the desired output current with the voltage and current supply that is available on the board using the variables listed in this section. An example is shown to illustrate the voltage regulator selection process.

Synchronous Switching Regulator Example

This example shows a worst-case scenario for power consumption where the design uses all the LEs and RAM. Table 12–7 shows the design requirements for 1.5-V design using a Cyclone EP1C12 FPGA.

Design Requirement	Value
Output voltage precision requirement	±5%
Supply voltages available on the board	3.3 V
Voltage supply output current available for this section ($I_{IN, DC(MAX)}$)	2 A
Variance of board supply (V_{IN})	±5%
f_{MAX}	150 MHz
Average t_{ogIO}	12.5%
Average t_{ogLC}	12.5%
Utilization	100%
Output and bidirectional pins	125
V_{CCIO} supply level	3.3 V
V_{CCINT} supply level	1.5 V
Efficiency	≥90%

Table 12–8 uses the checklist on page 12–8 to help select the appropriate voltage regulator.

Output voltage requirements	$V_{OUT} = 1.5\text{ V}$
Supply voltages	V_{IN} OR $V_{CC} = 3.3\text{ V}$
Supply variance from Linear Technology data sheet	Supply variance = ±5%
Estimated I_{CCINT} Use Cyclone Power Calculator	$I_{CCINT} = 620\text{ mA}$
Estimated I_{CCIO} if regulator powers V_{CCIO} Use Cyclone Power Calculator (not applicable in this example because $V_{CCIO} = 3.3\text{ V}$)	$I_{CCIO} = \text{N/A}$
Total user-mode current consumption $I_{CC} = I_{CCINT} + I_{CCIO}$	$I_{CC} = 620\text{ mA}$

Table 12–8. Voltage Regulator Selection Process for EP1C12F324C Design (Part 2 of 2)

EP1C12 maximum power-up current requirement See Power Consumption section of the Cyclone FPGA Family Data Sheet for other densities	$I_{PUC(MAX)} = 900 \text{ mA}$
Maximum output current required Compare I_{CC} with $I_{PUC(MAX)}$	$I_{OUT(MAX)} = 900 \text{ mA}$
Voltage regulator selection See <i>Linear Technology LTC 1649 data sheet</i> See <i>Intersil (Elantec) EL7562C data sheet</i>	LTC1649 $I_{OUT(MAX)} = 15 \text{ A}$ EL7562C $I_{OUT(MAX)} = 2 \text{ A}$
LTC1649	
Nominal efficiency (η)	Nominal efficiency (η) = > 90%
Line and load regulation Line regulation + load regulation = $(0.17 \text{ mV} + 7 \text{ mV}) / 1.5 \text{ V} \times 100\%$	Line and Load Regulation = 0.478% < 5%
Minimum input voltage ($V_{IN(MIN)}$) $(V_{IN(MIN)}) = V_{IN}(1 - \Delta V_{IN}) = 3.3\text{V}(1 - 0.05)$	$(V_{IN(MIN)}) = 3.135 \text{ V}$
Maximum input current $I_{IN, DC(MAX)} = (V_{OUT} \times I_{OUT(MAX)}) / (\eta \times V_{IN(MIN)})$	$I_{IN, DC(MAX)} = 478 \text{ mA} < 2 \text{ A}$
EL7562C	
Nominal efficiency (η)	Nominal efficiency (η) = > 95%
Line and load regulation Line regulation + load regulation = $(0.17 \text{ mV} + 7 \text{ mV}) / 1.5 \text{ V} \times 100\%$	Line and Load Regulation = 0.5% < 5%
Minimum input voltage ($V_{IN(MIN)}$) $(V_{IN(MIN)}) = V_{IN}(1 - \Delta V_{IN}) = 3.3\text{V}(1 - 0.05)$	$(V_{IN(MIN)}) = 3.135 \text{ V}$
Maximum input current $I_{IN, DC(MAX)} = (V_{OUT} \times I_{OUT(MAX)}) / (\eta \times V_{IN(MIN)})$	$I_{IN, DC(MAX)} = 453 \text{ mA} < 2 \text{ A}$

Board Layout

Laying out a printed circuit board (PCB) properly is extremely important in high-frequency ($\geq 100 \text{ kHz}$) switching regulator designs. A poor PCB layout results in increased EMI and ground bounce, which affects the reliability of the voltage regulator by obscuring important voltage and current feedback signals. Altera recommends using Gerber files—pre-designed layout files—supplied by the regulator vendor for your board layout.

If you cannot use the supplied layout files, contact the voltage regulator vendor for help on re-designing the board to fit your design requirements while maintaining the proper functionality.

Altera recommends that you use separate layers for signals, the ground plane, and voltage supply planes. You can support separate layers by using multi-layer PCBs, assuming you are using two signal layers.

Figure 12–18 shows how to use regulators to generate 1.5-V and 2.5-V power supplies if the system needs two power supply systems. One regulator is used for each power supply.

Figure 12–18. Two Regulator Solution for Systems that Require 5.0-V, 2.5-V and 1.5-V Supply Levels

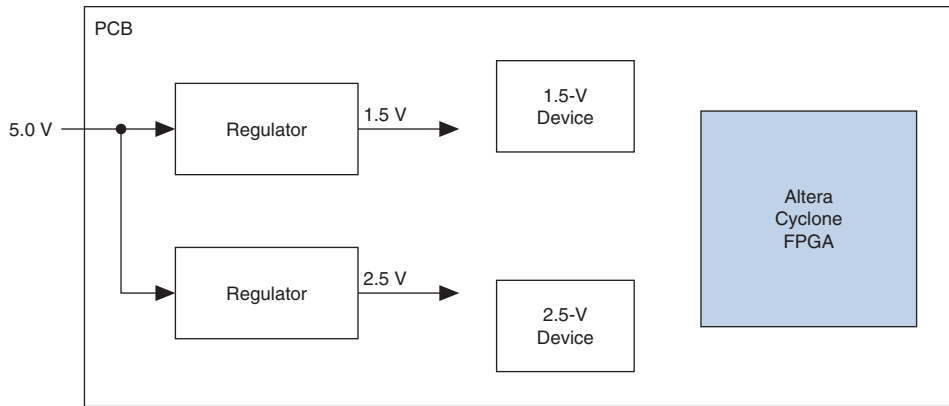
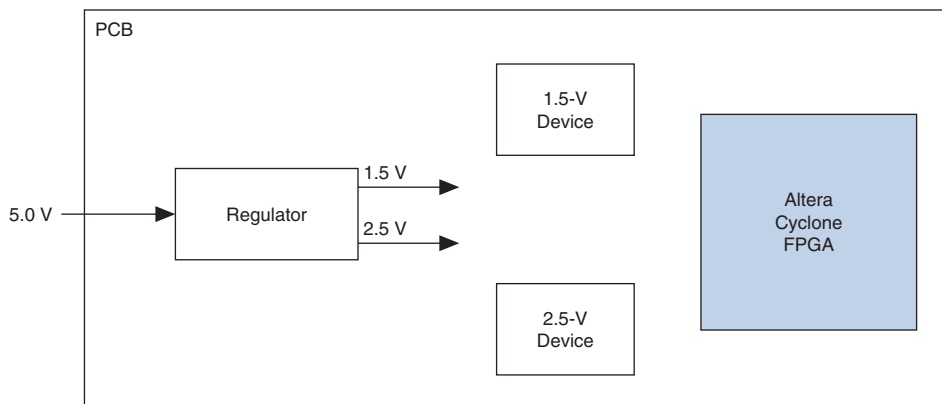

Figure 12–19 shows how to use a single regulator to generate two different power supplies (1.5-V and 2.5-V). The use of a single regulator to generate 1.5-V and 2.5-V supplies from the 5.0-V power supply can minimize the board size and thus save cost.

Figure 12–19. Single Regulator Solution for Systems that Require 5.0-V, 2.5-V and 1.5-V Supply Levels



Split-Plane Method

The split-plane design method reduces the number of planes required by placing two power supply planes in one plane (see [Figure 12–20](#)). For example, the layout for this method can be structured as follows:

- One 2.5-V plane, covering the entire board
- One plane split between 5.0-V and 1.5-V

This technique assumes that the majority of devices are 2.5-V. To support MultiVolt I/O, Altera devices must have access to 1.5-V and 2.5-V planes.

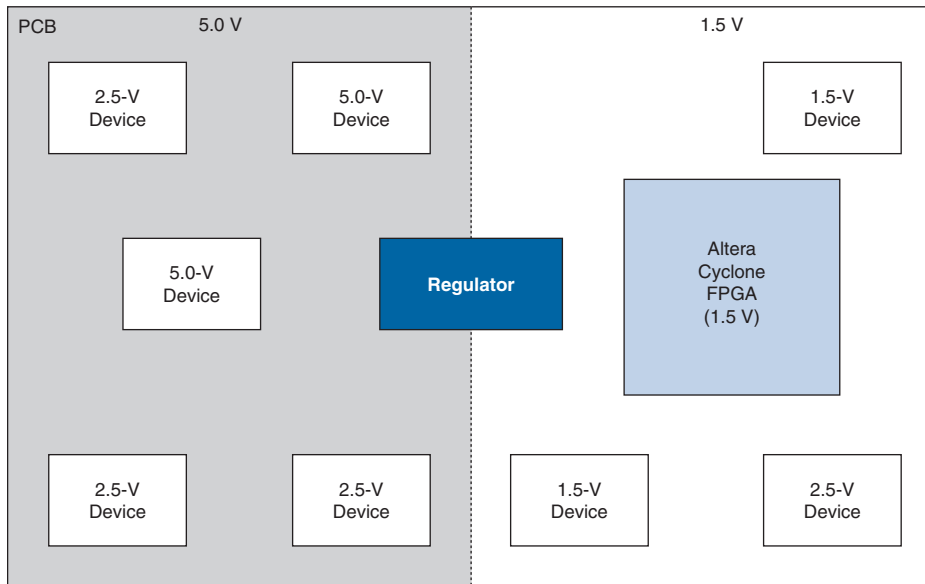
Figure 12–20. Split Board Layout for 2.5-V Systems With 5.0-V and 1.5-V Devices

Conclusion

With the proliferation of multiple voltage levels in systems, it is important to design a voltage system that can support a low-power device like Cyclone devices. Designers must consider key elements of the PCB, such as power supplies, regulators, power consumption, and board layout when successfully designing a system that incorporates the low-voltage Cyclone family of devices.

References

Linear Technology Corporation. *Application Note 35 (Step-Down Switching Regulators)*. Milpitas: Linear Technology Corporation, 1989.

Linear Technology Corporation. *LT1573 Data Sheet (Low Dropout Regulator Driver)*. Milpitas: Linear Technology Corporation, 1997.

Linear Technology Corporation. *LT1083/LT1084/LT1085 Data Sheet (7.5 A, 5 A, 3 A Low Dropout Positive Adjustable Regulators)*. Milpitas: Linear Technology Corporation, 1994.

Linear Technology Corporation. *LTC1649 Data Sheet (3.3V Input High Power Step-Down Switching Regulator Controller)*. Milpitas: Linear Technology Corporation, 1998.

Linear Technology Corporation. *LTC1775 Data Sheet (High Power No Rsense Current Mode Synchronous Step-Down Switching Regulator)*. Milpitas: Linear Technology Corporation, 1999.

Intersil Corporation. *EL7551C Data Sheet (Monolithic 1 Amp DC:DC Step-Down Regulator)*. Milpitas: Intersil Corporation, 2002.

Intersil Corporation. *EL7564C Data Sheet (Monolithic 4 Amp DC:DC Step-Down Regulator)*. Milpitas: Intersil Corporation, 2002.

Intersil Corporation. *EL7556BC Data Sheet (Integrated Adjustable 6 Amp Synchronous Switcher)*. Milpitas: Intersil Corporation, 2001.

Intersil Corporation. *EL7562C Data Sheet (Monolithic 2 Amp DC:DC Step-Down Regulator)*. Milpitas: Intersil Corporation, 2002.

Intersil Corporation. *EL7563C Data Sheet (Monolithic 4 Amp DC:DC Step-Down Regulator)*. Milpitas: Intersil Corporation, 2002.

Referenced Documents

This chapter references the following document:

- *Cyclone FPGA Family Data Sheet* section of the *Cyclone Device Handbook*

Document Revision History

Table 12–9 shows the revision history for this chapter.

<i>Table 12–9. Document Revision History</i>		
Date and Document Version	Changes Made	Summary of Changes
May 2008 v1.4	Minor textual and style changes. Added “Referenced Documents” section.	—
January 2007 v1.3	<ul style="list-style-type: none"> ● Added document revision history. ● Removed references to Stratix in “Introduction” and “Power Sequencing and Hot Socketing” sections. 	—
August 2005 v1.1	Minor updates.	—
May 2003 v1.0	Added document to Cyclone Device Handbook.	—

