

Stratix® III devices offers up to 1.6-Gbps differential I/O capabilities to support source-synchronous communication protocols such as Utopia, Rapid I/O®, XSBI, SGMII, SFI, and SPI.

Stratix III devices have the following dedicated circuitry for high-speed differential I/O support:

- Differential I/O buffer
- Transmitter serializer
- Receiver deserializer
- Data realignment
- Dynamic phase aligner (DPA)
- Synchronizer (FIFO buffer)
- Analog Phase-Locked Loops (PLLs) (located on left and right sides of the device)

For high-speed differential interfaces, Stratix III devices support the following differential I/O standards:

- Low voltage differential signaling (LVDS)
- Mini-LVDS
- Reduced swing differential signaling (RSDS)
- High-speed Transceiver Logic (HSTL)
- Stub Series Terminated Logic (SSTL)

I/O Banks

Stratix III I/Os are divided into 16 to 24 I/O banks. The dedicated serializer and deserializer (SERDES) circuitry with DPA that supports high-speed differential I/Os is located in banks in the right side and left side of the device. Figure 9-1 shows the different banks and the I/O standards supported by the banks.

Figure 9-1. I/O Banks in Stratix III Devices (Note 1), (2), (3), (4), (5), (6)

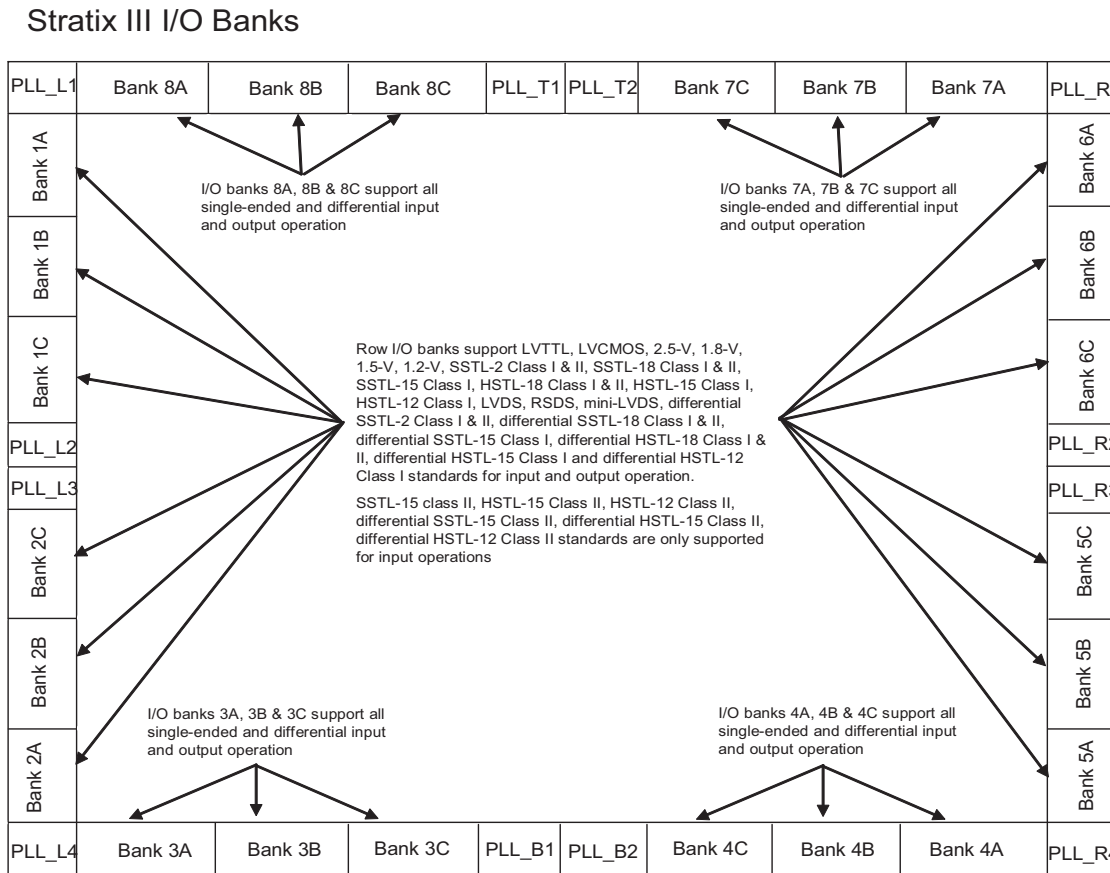

Notes to Figure 9-1:

- (1) Figure 9-1 is a top view of the silicon die that corresponds to a reverse view for flip chip packages. It is a graphical representation only. For exact locations, refer to the pin list and the Quartus II software.
- (2) Differential HSTL and SSTL outputs use two single-ended (SE) outputs with the second output programmed as inverted to support differential I/O operations.
- (3) Column I/O differential HSTL and SSTL inputs use LVDS differential input buffers without on-chip differential termination ($OCT R_D$) support.
- (4) Column I/O supports LVDS outputs using SE buffers and external resistor networks.
- (5) Row I/O supports PCI/PCI-X without on-chip clamping diodes.
- (6) The PLL blocks are shown for location purposes only and are not considered additional banks. The PLL input and output uses the I/Os in adjacent banks.

LVDS Channels

The Stratix III device supports LVDS on both side I/O banks and column I/O banks. Single-ended reference clocks are supported when using the source-synchronous SERDES in DPA and soft-CDR mode. There are true LVDS input and output buffers on the side I/O banks. On column I/O banks, there are true LVDS input buffers but do not have true LVDS output buffers. However, you can configure all column user I/Os—including I/Os with true LVDS input buffers—as emulated LVDS output buffers. When using emulated LVDS standards, you must implement the logic driving these pins in soft logic (logic elements) and not hard SERDES.

 Emulated differential output buffers support tri-state capability starting with the Quartus® II software version 9.1.

Table 9-1 lists the LVDS channels supported in Stratix III device side I/O banks.

Table 9-1. LVDS Channels Supported in Stratix III Device Side I/O Banks (Note 1), (2), (3)

Device	484-Pin FineLine BGA	780-Pin FineLine BGA	1152-Pin FineLine BGA	1517-Pin FineLine BGA	1780-Pin FineLine BGA
EP3SL50	48Rx/eTx + 48Tx/eTx	56Rx/eTx + 56Tx/eTx	—	—	—
EP3SL70	48Rx/eTx + 48Tx/eTx	56Rx/eTx + 56Tx/eTx	—	—	—
EP3SL110	—	56Rx/eTx + 56Tx/eTx	88Rx/eTx + 88Tx/eTx	—	—
EP3SL150	—	56Rx/eTx + 56Tx/eTx	88Rx/eTx + 88Tx/eTx	—	—
EP3SL200	—	56Rx/eTx + 56Tx/eTx (4)	88Rx/eTx + 88Tx/eTx	112Rx/eTx + 112Tx/eTx	—
EP3SL340	—	—	88Rx/eTx + 88Tx/eTx (5)	112Rx/eTx + 112Tx/eTx	132Rx/eTx + 132Tx/eTx
EP3SE50	48Rx/eTx + 48Tx/eTx	56Rx/eTx + 56Tx/eTx	—	—	—
EP3SE80	—	56Rx/eTx + 56Tx/eTx	88Rx/eTx + 88Tx/eTx	—	—
EP3SE110	—	56Rx/eTx + 56Tx/eTx	88Rx/eTx + 88Tx/eTx	—	—
EP3SE260	—	56Rx/eTx + 56Tx/eTx (4)	88Rx/eTx + 88Tx/eTx	112Rx/eTx + 112Tx/eTx	—

Notes to Table 9-1:

- (1) Rx = true LVDS input buffers.
- (2) Tx = true LVDS output buffers.
- (3) eTx = emulated-LVDS output buffers, either LVDS_E3R or LVDS_E1R.
- (4) The EP3SL200 and EP3SL260 FPGAs are offered in the H780 package, instead of the F780 package.
- (5) The EP3SL340 FPGA is offered in the H1152 package, instead of the F1152 package.

Table 9-2 lists the LVDS channels (emulated) supported in Stratix III device column I/O banks.

Table 9-2. LVDS Channels (Emulated) Supported in Stratix III Device Column I/O Banks (Note 1), (2)

Device	484-Pin FineLine BGA	780-Pin FineLine BGA	1152-Pin FineLine BGA	1517-Pin FineLine BGA	1780-Pin FineLine BGA
EP3SL50	24Rx/eTx + 24eTx	64Rx/eTx + 64eTx	—	—	—
EP3SL70	24Rx/eTx + 24eTx	64Rx/eTx + 64eTx	—	—	—
EP3SL110	—	64Rx/eTx + 64eTx	96Rx/eTx + 96eTx	—	—
EP3SL150	—	64Rx/eTx + 64eTx	96Rx/eTx + 96eTx	—	—
EP3SL200	—	64Rx/eTx + 64eTx (3)	96Rx/eTx + 96eTx	128Rx/eTx + 128eTx	—
EP3SL340	—	—	96Rx/eTx + 96eTx (4)	128Rx/eTx + 128eTx	144Rx/eTx + 144eTx
EP3SE50	24Rx/eTx + 24eTx	64Rx/eTx + 64eTx	—	—	—
EP3SE80	—	64Rx/eTx + 64eTx	96Rx/eTx + 96eTx	—	—
EP3SE110	—	64Rx/eTx + 64eTx	96Rx/eTx + 96eTx	—	—
EP3SE260	—	64Rx/eTx + 64eTx (3)	96Rx/eTx + 96eTx	128Rx/eTx + 128eTx	—

Notes to Table 9-2:

- (1) Rx = true LVDS input buffers without on-chip differential input termination.
- (2) eTx = emulated LVDS output buffers, either LVDS_E3R or LVDS_E1R.
- (3) The EP3SL200 and EP3SE260 FPGAs are offered in the H780 package, instead of the F780 package.
- (4) The EP3SL340 FPGA is offered in the H1152 package, instead of the F1152 package.

Differential Transmitter

The Stratix III transmitter has dedicated circuitry to provide support for LVDS signaling. The dedicated circuitry consists of a differential buffer, a serializer, and a shared analog PLL (left/right PLL). The differential buffer can drive out LVDS, mini-LVDS, and RSDS signaling levels. The serializer takes up to 10-bits wide parallel data from the FPGA core, clocks it into the load registers, and serializes it using shift registers clocked by the left/right PLL before sending the data to the differential buffer. The most significant bit (MSB) of the parallel data is transmitted first.

The load and shift registers are clocked by the load enable (`load_en`) signal and the `diffioclk` (clock running at serial data rate) signal generated from PLL_Lx (left PLL) or PLL_Rx (right PLL). The serialization factor can be statically set to $\times 3$, $\times 4$, $\times 5$, $\times 6$, $\times 7$, $\times 8$, $\times 9$, or $\times 10$ with the Quartus II software. The load enable signal is derived from the serialization factor setting. Figure 9-2 shows a block diagram of the Stratix III transmitter.

Figure 9-2. Transmitter Block Diagram for Stratix III Devices

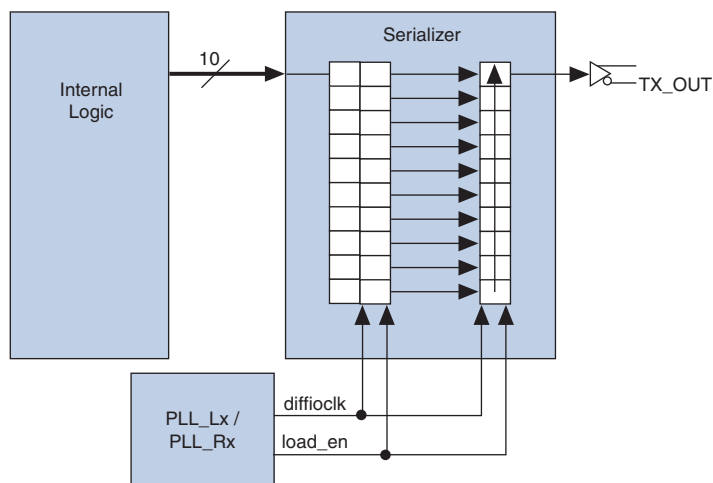

You can configure any Stratix III transmitter data channel to generate a source-synchronous transmitter clock output. This flexibility allows placing the output clock near the data outputs to simplify board layout and reduce clock-to-data skew. Different applications often require specific clock-to-data alignments or specific data rate-to-clock rate factors. The transmitter can output a clock signal at the same rate as the data with a maximum frequency of 800 MHz. You can also divide the output clock by a factor of 2, 4, 8, or 10, depending on the serialization factor. The phase of the clock in relation to the data can be set at 0° or 180° (edge or center aligned). The left and right PLLs (PLL_Lx/PLL_Rx) provide additional support for other phase shifts in 45° increments. These settings are statically made in the MegaWizard® Plug-In Manager in the Quartus II software.

Figure 9-3 shows the Stratix III transmitter in clock output mode.

Figure 9-3. Transmitter in Clock Output Mode for Stratix III Devices

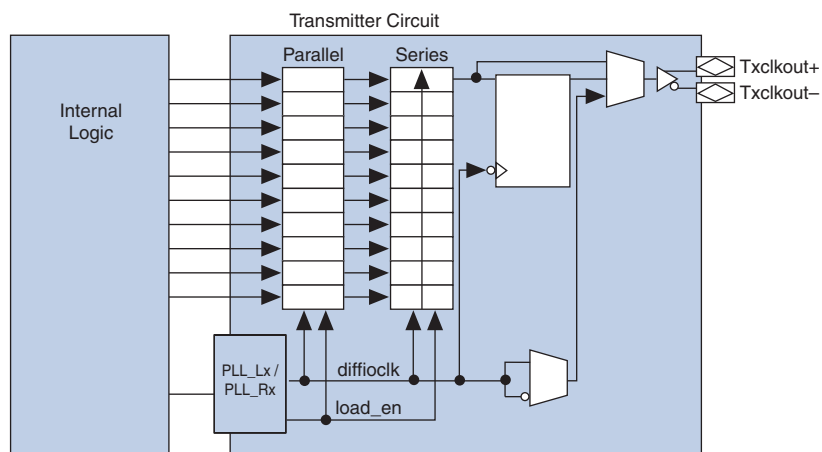

You can bypass the Stratix III serializer to support DDR ($\times 2$) and SDR ($\times 1$) operations to achieve a serialization factor of 2 and 1, respectively. The I/O element (IOE) contains two data output registers that can each operate in either DDR or SDR mode. The clock source for the registers in the IOE can come from any routing resource, from the left/right PLL (PLL_Lx/PLL_Rx) or from the top/bottom (PLL_Tx/PLL_Bx) PLL.

Figure 9-4 shows the serializer bypass path.

Figure 9-4. Serializer Bypass for Stratix III Devices

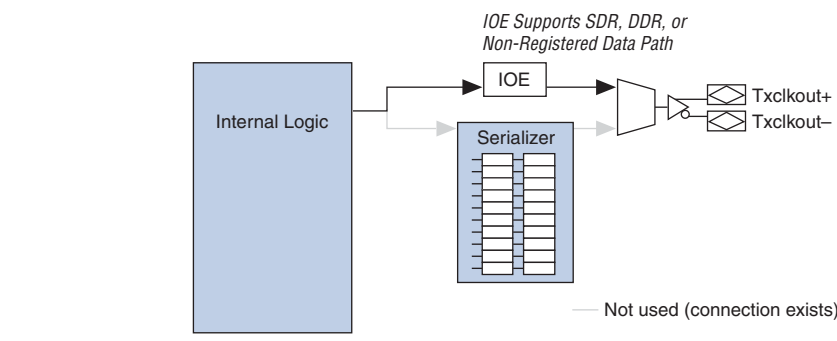

For more information about how to use the differential transmitter, refer to the *ALTLVDS Megafunction User Guide*.

Differential Receiver

The Stratix III device has dedicated circuitry to receive high-speed differential signals. The receiver has a differential buffer, a shared PLL_Lx/PLL_Rx, DPA block, synchronization FIFO buffer, data realignment block, and a deserializer. The differential buffer can receive LVDS, mini-LVDS, and RSDS signal levels, which are statically set in the Quartus II software Assignment Editor. The PLL receives the external source clock input that is transmitted with the data and generates different phases of the same clock. The DPA block chooses one of the clocks from the left/right PLL and aligns the incoming data on each channel.

The synchronizer circuit is a 1-bit wide by 6-bit deep FIFO buffer that compensates for any phase difference between the DPA clock and the data realignment block. If necessary, the data realignment circuit can insert a single bit of latency in the serial bit stream to align to the word boundary. The deserializer includes shift registers and parallel load registers, and sends a maximum of 10 bits to the internal logic. The data path in the Stratix III receiver is clocked by either a `dffioclk` signal or the DPA recovered clock. The deserialization factor can be statically set to $\times 3$, $\times 4$, $\times 5$, $\times 6$, $\times 7$, $\times 8$, $\times 9$, or $\times 10$ with the Quartus II software. The left/right PLLs (PLL_Lx/PLL_Rx) generate the load enable signal, which is derived from the deserialization factor setting.

To support DDR ($\times 2$) or SDR ($\times 1$) operations, you can bypass the Stratix III deserializer in MegaWizard Plug-In Manager in the Quartus II software. You cannot use the DPA and the data realignment circuit when the deserializer is bypassed. The IOE contains two data input registers that can operate in DDR or SDR mode. The clock source for the registers in the IOE can come from any routing resource, from the left/right PLLs or from the top/bottom PLLs. Figure 9-5 shows the block of the Stratix III receiver.

Figure 9-5. Receiver Block Diagram for Stratix III Devices

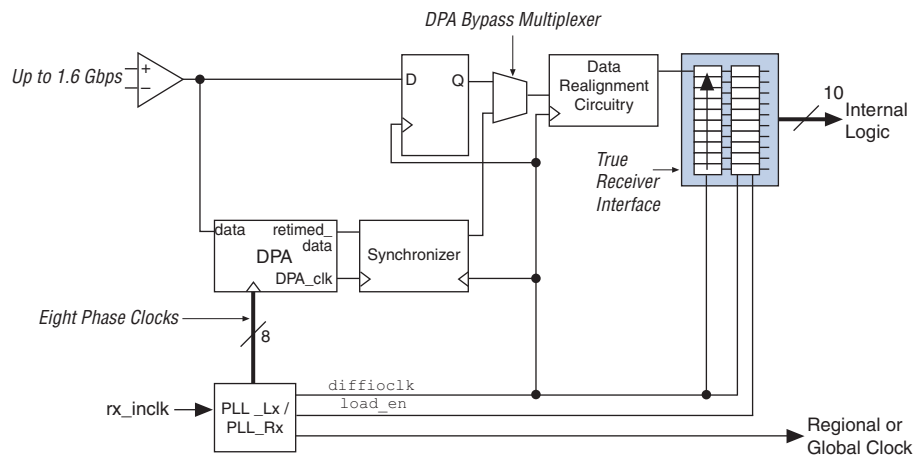
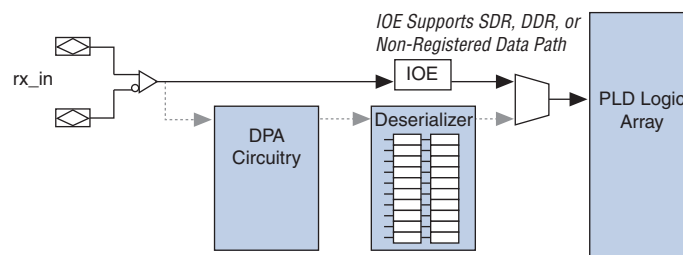

Figure 9-6 shows the deserializer bypass data path.

Figure 9-6. Deserializer Bypass for Stratix III Devices



Receiver Data Realignment Circuit (Bit Slip)

Skew in the transmitted data along with skew added by the link causes channel-to-channel skew on the received serial data streams. If DPA is enabled, the received data is captured with different clock phases on each channel. This may cause the received data to be misaligned from channel to channel. To compensate for this channel-to-channel skew and establish the correct received word boundary at each channel, each receiver channel has a dedicated data realignment circuit that realigns the data by inserting bit latencies into the serial stream.

An optional `RX_CHANNEL_DATA_ALIGN` port controls the bit insertion of each receiver independently controlled from the internal logic. The data slips one bit for every pulse on the `RX_CHANNEL_DATA_ALIGN`. The following are requirements for the `RX_CHANNEL_DATA_ALIGN` signal:

- The minimum pulse width is one period of the parallel clock in the logic array
- The minimum low time between pulses is one period of parallel clock
- There is no maximum high or low time
- Valid data is available two parallel clock cycles after the rising edge of `RX_CHANNEL_DATA_ALIGN`

Figure 9-7 shows receiver output (RX_OUT) after one bit slip pulse with the deserialization factor set to 4.

Figure 9-7. Data Realignment Timing

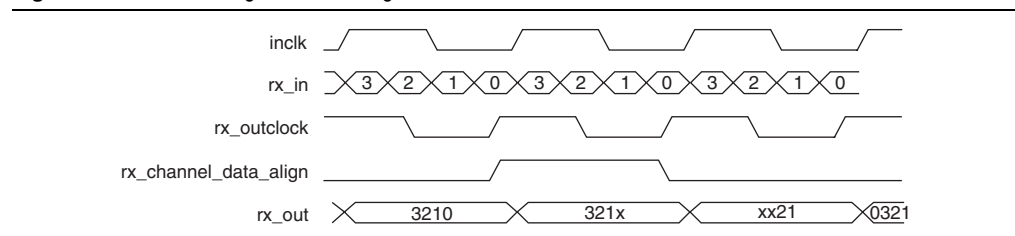

The data realignment circuit can have up to 11 bit-times of insertion before a rollover occurs. The programmable bit rollover point can be from 1 to 11 bit-times, independent of the deserialization factor. An optional status port, RX_CDA_MAX, is available to the FPGA from each channel to indicate when the preset rollover point is reached.

Dynamic Phase Aligner (DPA)

The DPA block takes in high-speed serial data from the differential input buffer and selects one of the eight phase clocks from the left/right PLL to sample the data. The DPA chooses the phase closest to the phase of the serial data. The maximum phase offset between the received data and the selected phase is $1/8$ UI, which is the maximum quantization error of the DPA. The eight phases of the clock are equally divided, giving a 45° resolution.

Figure 9-8 shows the possible phase relationships between the DPA clocks and the incoming serial data.

Figure 9-8. DPA Clock Phase-to-Serial Data Timing Relationship

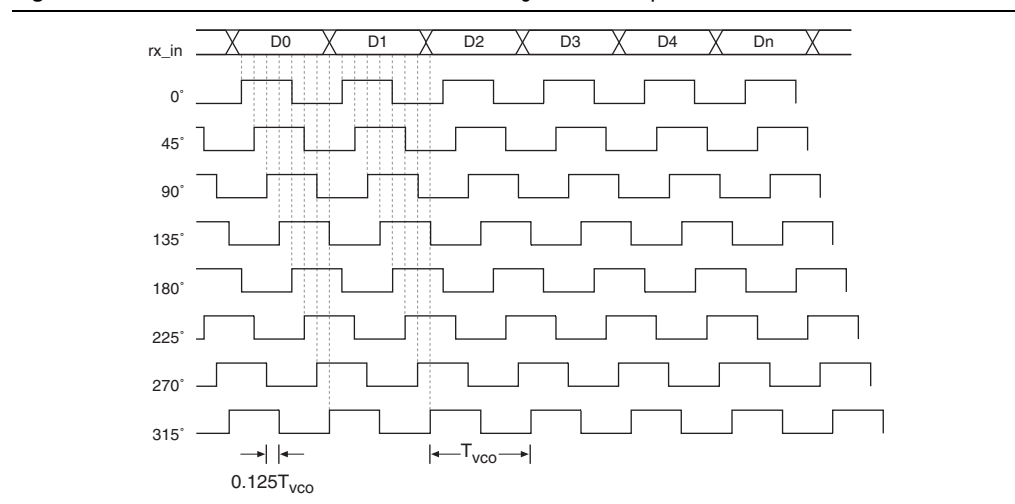

The DPA block continuously monitors the phase of the incoming serial data and selects a new clock phase if required. You can prevent the DPA from selecting a new clock phase by asserting the optional RX_DPLL_HOLD port, which is available for each channel.

The DPA circuitry does not require a fixed training pattern to lock to the optimum phase out of the 8 phases. After reset or power up, the DPA circuitry requires transitions on the received data to lock to the optimum phase. The ALTLVDS megafunction provides an optional output port, `rx_dpa_locked` to indicate if the DPA has locked to the optimum phase. When the DPA locks to the optimum phase, the `rx_dpa_locked` signal always stays high unless you assert the `rx_reset` signal of the associated LVDS channel or the `pll_areset` signal of the receiver PLL providing the 8 DPA clock phases.

 The `rx_dpa_locked` signal only indicates an initial DPA lock condition to the optimum phase after power up or reset. You must not use the `rx_dpa_locked` signal to validate the integrity of the LVDS link. Use error checkers, for example cyclical redundancy check (CRC) and diagonal interleave parity (DIP4), to validate the integrity of the LVDS link.

An independent reset port (`RX_RESET`) is available to reset the DPA circuitry. You must retrain the DPA circuitry after reset.

Soft-CDR Mode

The Stratix III LVDS channel offers the soft-CDR mode to support the Gigabit Ethernet/SGMII protocols. Clock-data recovery (CDR) is required to extract the clock out of the clock-embedded data to support SGMII. In Stratix III devices, the CDR circuit is implemented in soft-logic as an IP.

In soft-CDR mode, the DPA circuitry selects an optimal DPA clock phase to sample the data and carry on the bit-slip operation and deserialization. The selected DPA clock is also divided down by the deserialization factor, and then forwarded to the PLD core along with the deserialized data. The LVDS block has an output called `DIVCLKOUT` (`rx_divfwdclk` port of the ALTLVDS megafunction) for the forwarded clock signal. This signal is put on the newly introduced periphery clock (PCLK) network. When using soft-CDR mode, the `rx_reset` port should not be asserted when the `rx_dpa_lock` is asserted because the DPA will continually choose new phase taps from the PLL to track parts per million (PPM) differences between the reference clock and incoming data. In Stratix III devices, you can use every LVDS channel in soft-CDR mode and can drive the core via the PCLK network.

Figure 9-9 shows the path enabled in soft-CDR mode.

Figure 9-9. Soft-CDR Data and Clock Path for a Stratix III Devices

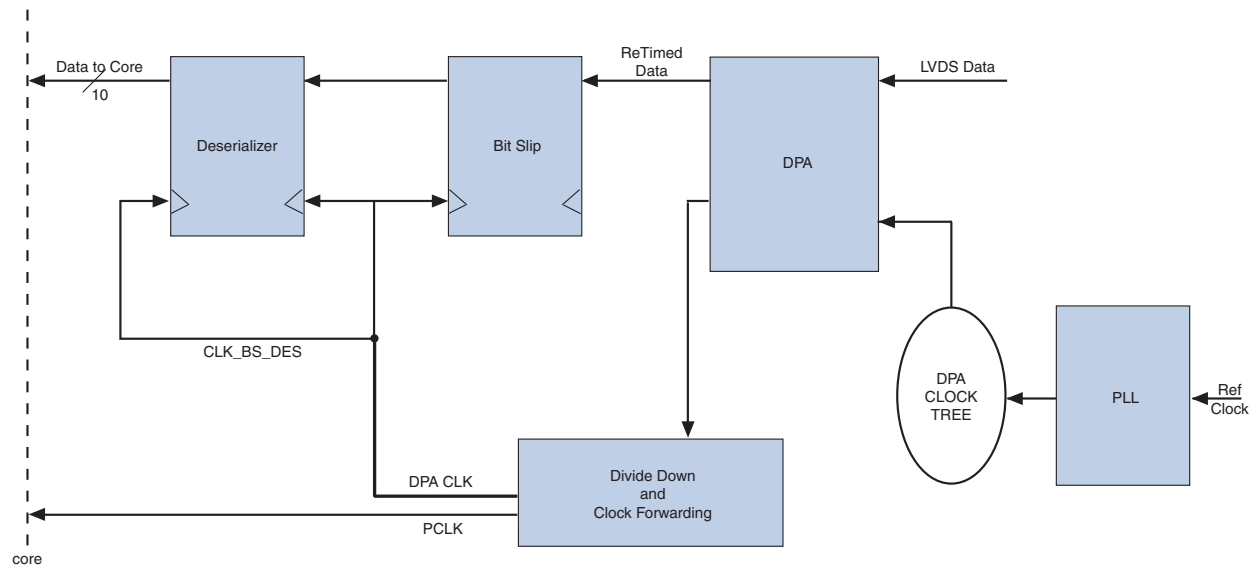

 The synchronizer FIFO is bypassed in soft-CDR mode. The reference clock frequency must be suitable for the PLL to generate a clock that matches the data rate of the interface. The DPA circuitry can track PPM differences between the reference clock and the data stream.

Synchronizer

The synchronizer is a 1-bit × 6-bit deep FIFO buffer that compensates for the phase difference between the recovered clock from the DPA circuit and the `diffioclk` that clocks the rest of the logic in the receiver. The synchronizer can only compensate for phase differences, not frequency differences between the data and the receiver's `INCLK`.

An optional port (`RX_FIFO_RESET`) is available to the internal logic to reset the synchronizer. Altera® recommends using `RX_FIFO_RESET` to reset the synchronizer once after the `RX_DPA_LOCKED` signal gets asserted and before valid data is received.

 For more information about how to use the differential receiver, refer to the [ALTLVDS Megafunction User Guide](#).

Programmable Pre-Emphasis and Programmable V_{OD}

Stratix III LVDS transmitters support programmable pre-emphasis and programmable voltage output differential (V_{OD}). Pre-emphasis increases the amplitude of the high frequency component of the output signal, and thus helps compensate for the frequency dependent attenuation along the transmission line. Figure 9-10 shows an LVDS output with pre-emphasis. The overshoot is produced by pre-emphasis. This overshoot should not be included in the V_{OD} voltage. The definition of V_{OD} is also shown in Figure 9-10.

Figure 9-10. Programmable V_{OD}

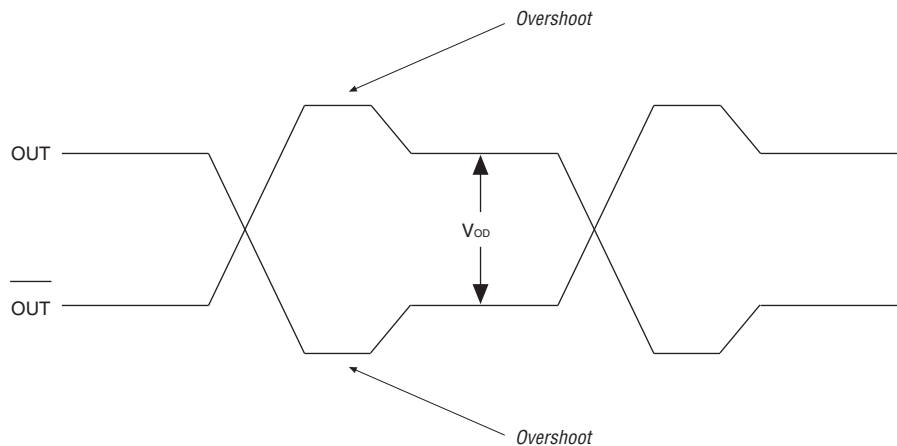

Pre-emphasis is an important feature for high-speed transmission. Without pre-emphasis, the output current is limited by the V_{OD} setting and the output impedance of the driver. At high frequency, the slew rate may not be fast enough to reach the full V_{OD} before the next edge, producing a pattern dependent jitter.

With pre-emphasis, the output current is boosted momentarily during switching to increase the output slew rate. The overshoot introduced by the extra current happens only during switching and does not ring, unlike the overshoot caused by signal reflection. The amount of pre-emphasis required depends on the attenuation of the high-frequency component along the transmission line.

Stratix III pre-emphasis is programmable to create the right amount of overshoot at different transmission conditions. There are four settings for pre-emphasis: zero, low, medium, and high. The default setting is low. In the Quartus II Assignment Editor, pre-emphasis settings are represented in numbers with 0 (zero), 1 (low), 2 (medium) and 3 (high). For a particular design, simulation with an LVDS buffer and transmission line can be used to determine the best pre-emphasis setting.

The V_{OD} is also programmable with four settings: low, medium low, medium high, and high. The default setting is medium low. In the Quartus II Assignment Editor, programmable V_{OD} settings are represented in numbers with 0 (low), 1 (medium low), 2 (medium high) and 3 (high).

Differential I/O Termination

Stratix III devices provide a 100- Ω OCT R_D option on each differential receiver channel for LVDS standards. OCT saves board space by eliminating the need to add external resistors on the board. You can enable OCT in the Quartus II software Assignment Editor.

OCT R_D is supported on all row I/O pins and SERDES block clock pins: CLK (0, 2, 9, and 11). It is not supported for column I/O pins, high-speed clock pins CLK [1, 3, 8, 10], or the corner PLL clock inputs.

Figure 9-11 shows the device OCT.

Figure 9-11. On-Chip Differential I/O Termination for Stratix III Devices

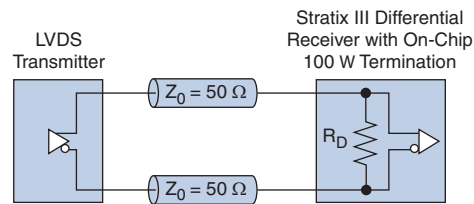

Left/Right PLLs (PLL_Lx/ PLL_Rx)

Stratix III devices contain up to eight left/right PLLs, with up to four PLLs located on the left side and four on the right side of the device. The left PLLs can support high-speed differential I/O banks on the left side and the right PLLs can support banks on the right side of the device. The high-speed differential I/O receiver and transmitter channels use these left/right PLLs to generate the parallel global clocks (rx- or tx-clock) and high-speed clocks (diffioclk). Figure 9-1 shows the locations of the left/right PLLs. The PLL VCO operates at the clock frequency of the data rate. Each left/right PLL offers a single serial data rate support, but up to two separate serialization and/or deserialization factors (from the C0 and C1 left/right PLL clock outputs). Clock switchover and dynamic left/right PLL reconfiguration is available in high-speed differential I/O support mode.

 For more information, refer to the *Clock Network and PLLs in Stratix III Devices* chapter.

Figure 9-12 shows a simplified block diagram of the major components of the Stratix III PLL.

Figure 9-12. PLL Block Diagram for Stratix III Devices

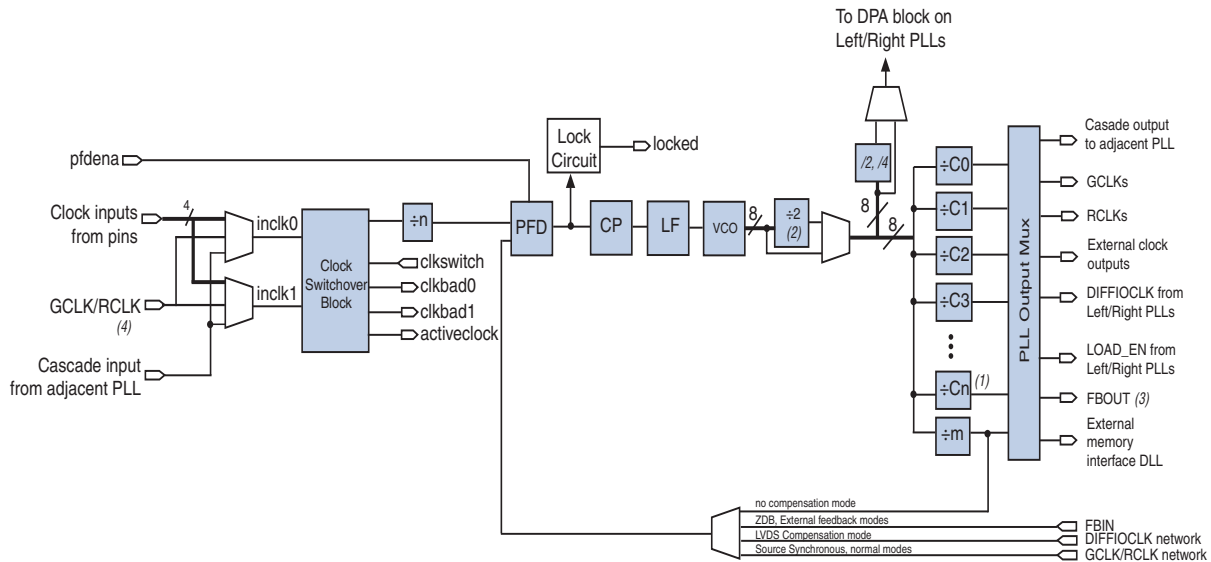

Notes to Figure 9-12:

- (1) $n = 6$ for Left/Right PLLs; $n = 9$ for Top/Bottom PLLs.
- (2) This is the VCO post-scale counter κ .
- (3) The $FBOUT$ port is fed by the M counter in Stratix III PLLs.
- (4) The global or regional clock input can be driven by an output from another PLL, a pin-driven dedicated global or regional clock, or through a clock control block provided the clock control block is fed by an output from another PLL or a pin-driven dedicated global or regional clock. An internally generated global signal or general purpose I/O pin cannot drive the PLL.

Clocking

The left/right PLLs feed into the differential transmitter and receive channels through the LVDS and DPA clock network. The center left/right PLLs can clock the transmitter and receive channels above and below them. The corner left/right PLLs can drive I/Os in the banks adjacent to them. [Figure 9-13](#) and [Figure 9-14](#) show center and corner PLL clocking in Stratix III devices. You can find more information about PLL clocking restrictions in [“Differential Pin Placement Guidelines”](#) on page 9-19.

Figure 9-13. LVDS/DPA Clocks with Center PLLs for Stratix III Devices

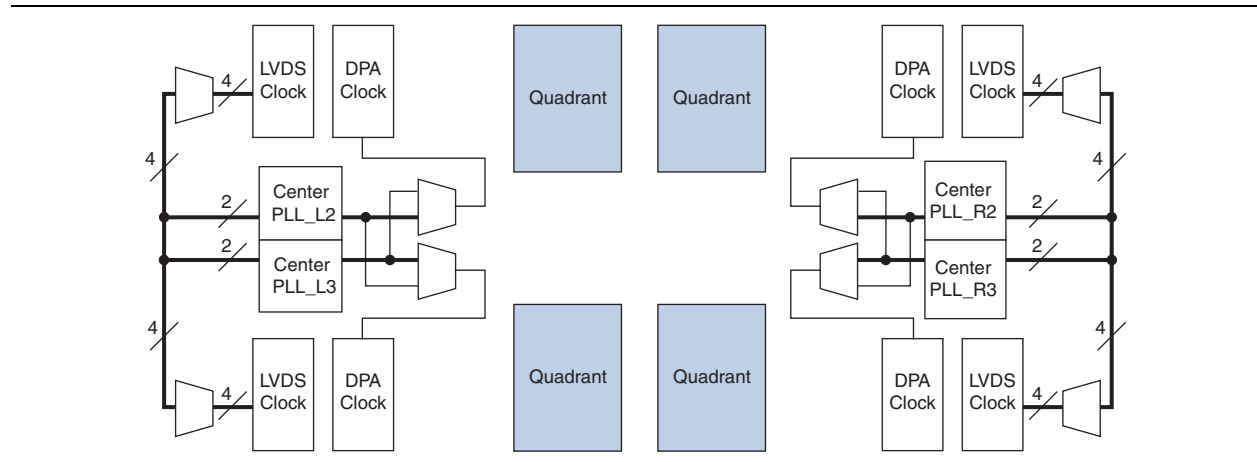
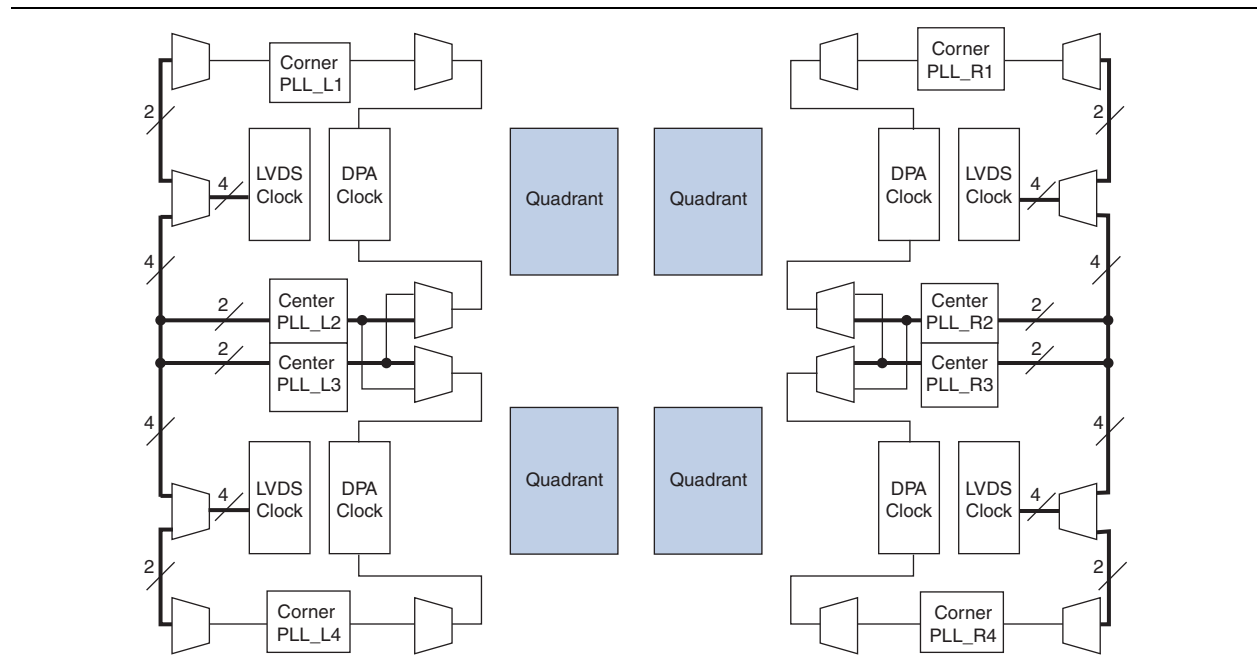

Figure 9-14. LVDS/DPA Clocks with Center and Corner PLLs for Stratix III Devices



Source-Synchronous Timing Budget

This section discusses the timing budget, waveforms, and specifications for source-synchronous signaling in Stratix III devices. LVDS I/O standards enable high-speed data transmission. This high data transmission rate results in better overall system performance. To take advantage of fast system performance, it is important to understand how to analyze timing for these high-speed signals. Timing analysis for the differential block is different from traditional synchronous timing analysis techniques.

Rather than focusing on clock-to-output and setup times, source synchronous timing analysis is based on the skew between the data and the clock signals. High-speed differential data transmission requires the use of timing parameters provided by IC vendors and is strongly influenced by board skew, cable skew, and clock jitter. This section defines the source-synchronous differential data orientation timing parameters, the timing budget definitions for Stratix III devices, and ways to use these timing parameters to determine the maximum performance of your design.

Differential Data Orientation

There is a set relationship between an external clock and the incoming data. For an operation at 1 Gbps and SERDES factor of 10, the external clock is multiplied by 10, and phase-alignment can be set in the PLL to coincide with the sampling window of each data bit. The data is sampled on the falling edge of the multiplied clock.

Figure 9-15 shows the data bit orientation of the $\times 10$ mode.

Figure 9-15. Bit Orientation in Quartus II Software

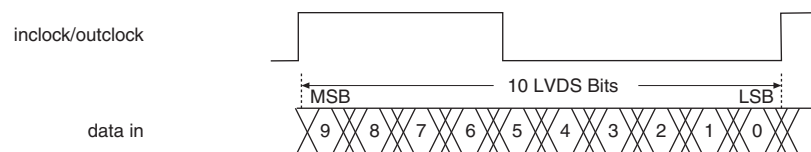

Differential I/O Bit Position

Data synchronization is necessary for successful data transmission at high frequencies. Figure 9-16 shows the data bit orientation for a channel operation. These figures are based on the following:

- SERDES factor equals clock multiplication factor
- Edge alignment is selected for phase alignment
- Implemented in hard SERDES

For other serialization factors, use the Quartus II software tools and find the bit position within the word and the bit positions after deserialization.

Figure 9-16. Bit-Order and Word Boundary for One Differential Channel (Note 1)

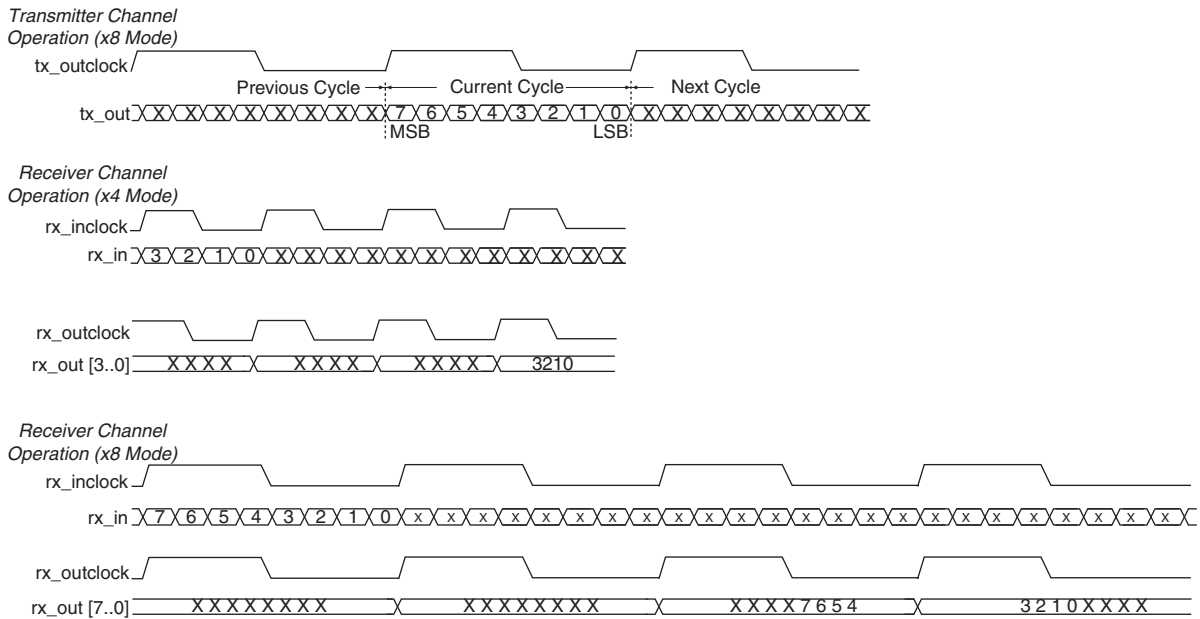

Note to Figure 9-16:

(1) These are only functional waveforms and are not intended to convey timing information.

Table 9-3 lists the conventions for differential bit naming for 18 differential channels. The MSB and LSB positions increase with the number of channels used in a system.

Table 9-3. Differential Bit Naming (Part 1 of 2)

Receiver Channel Data Number	Internal 8-Bit Parallel Data	
	MSB Position	LSB Position
1	7	0
2	15	8
3	23	16
4	31	24
5	39	32
6	47	40
7	55	48
8	63	56
9	71	64
10	79	72
11	87	80
12	95	88
13	103	96
14	111	104
15	119	112
16	127	120

Table 9-3. Differential Bit Naming (Part 2 of 2)

Receiver Channel Data Number	Internal 8-Bit Parallel Data	
	MSB Position	LSB Position
17	135	128
18	143	136

Receiver Skew Margin for Non-DPA

Changes in system environment, such as temperature, media (cable, connector, or PCB) loading effect, the receiver's setup and hold times, and internal skew, reduce the sampling window for the receiver. The timing margin between the receiver's clock input and the data input sampling window is called receiver skew margin (RSKM). [Figure 9-17](#) shows the relationship between the RSKM and the sampling window of the receiver.

Transmit channel-to-channel skew (TCCS), RSKM, and the sampling window specifications are used for high-speed source-synchronous differential signals without DPA. When using DPA, these specifications are exchanged for the simpler single DPA jitter tolerance specification. For instance, the receiver skew is why each input with DPA selects a different phase of the clock, thus removing the requirement for this margin. In the timing diagram, TSW represents time for the sampling window.

Figure 9-17. Differential High-Speed Timing Diagram and Timing Budget for Non-DPA

Timing Diagram

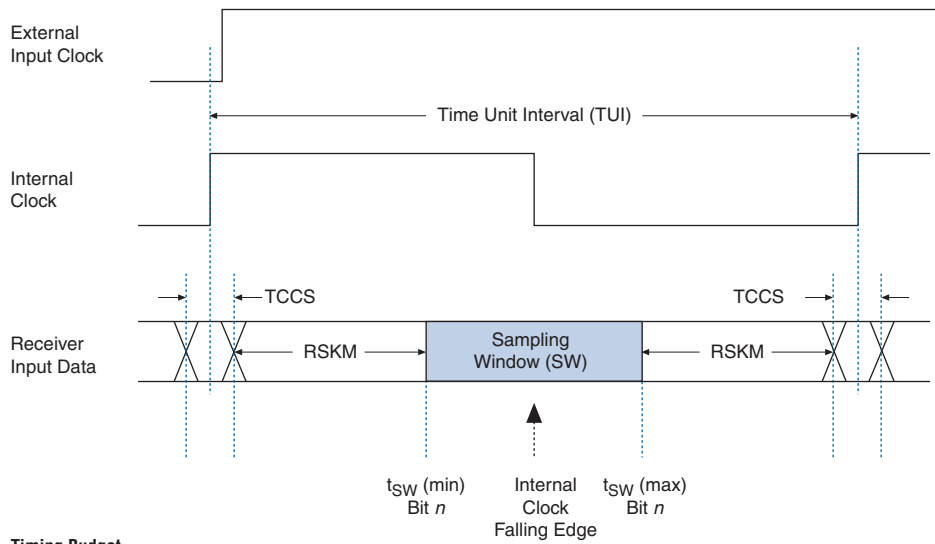

Timing Budget

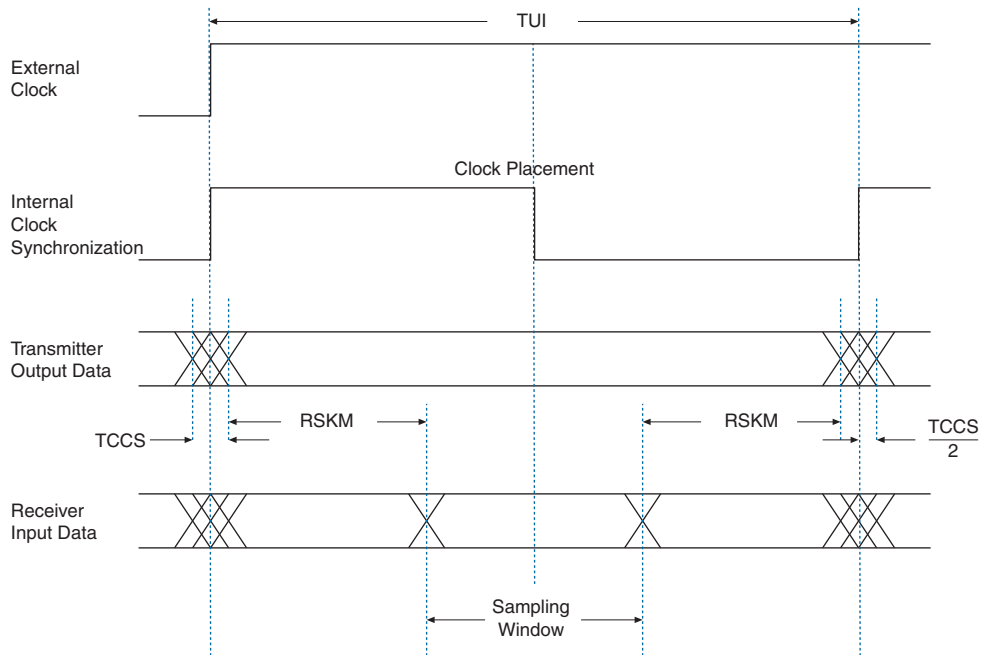

Differential Pin Placement Guidelines

To ensure proper high-speed operation, differential pin placement guidelines have been established. The Quartus II compiler automatically checks that these guidelines are followed and issues an error message if they are not met.

Because DPA usage adds some constraints on the placement of high-speed differential channels, this section is divided into pin placement guidelines with and without DPA usage.

Guidelines for DPA-Enabled Differential Channels

The Stratix III device has differential receivers and transmitters in I/O banks on the left and right sides of the device. Each receiver has a dedicated DPA circuit to align the phase of the clock to the data phase of its associated channel. When DPA-enabled channels are used in differential banks, you must adhere to the guidelines listed in the following sections.

DPA-Enabled Channels and Single-Ended I/Os

When there is a DPA channel enabled in a bank, both single-ended I/Os and differential I/O standards are allowed in the bank.

Single-ended I/Os are allowed in the same I/O bank as long as the single-ended I/O standard uses the same V_{CCIO} as the DPA-enabled differential I/O bank.

DPA-Enabled Channel Driving Distance

If the number of DPA channels driven by each left/right PLL exceeds 25 LAB rows, Altera recommends implementing data realignment (bit-slip) circuitry for all the DPA channels.

Using Corner and Center Left/Right PLLs

If a differential bank is being driven by two left/right PLLs, where the corner left/right PLL is driving one group and the center left/right PLL is driving another group, there must be at least one row of separation between the two groups of DPA-enabled channels (refer to [Figure 9-18](#)). The two groups can operate at independent frequencies.

No separation is necessary if a single left/right PLL is driving DPA-enabled channels as well as DPA-disabled channels.

Figure 9-18. Corner and Center Left/Right PLLs Driving DPA-Enabled Differential I/Os in the Same Bank

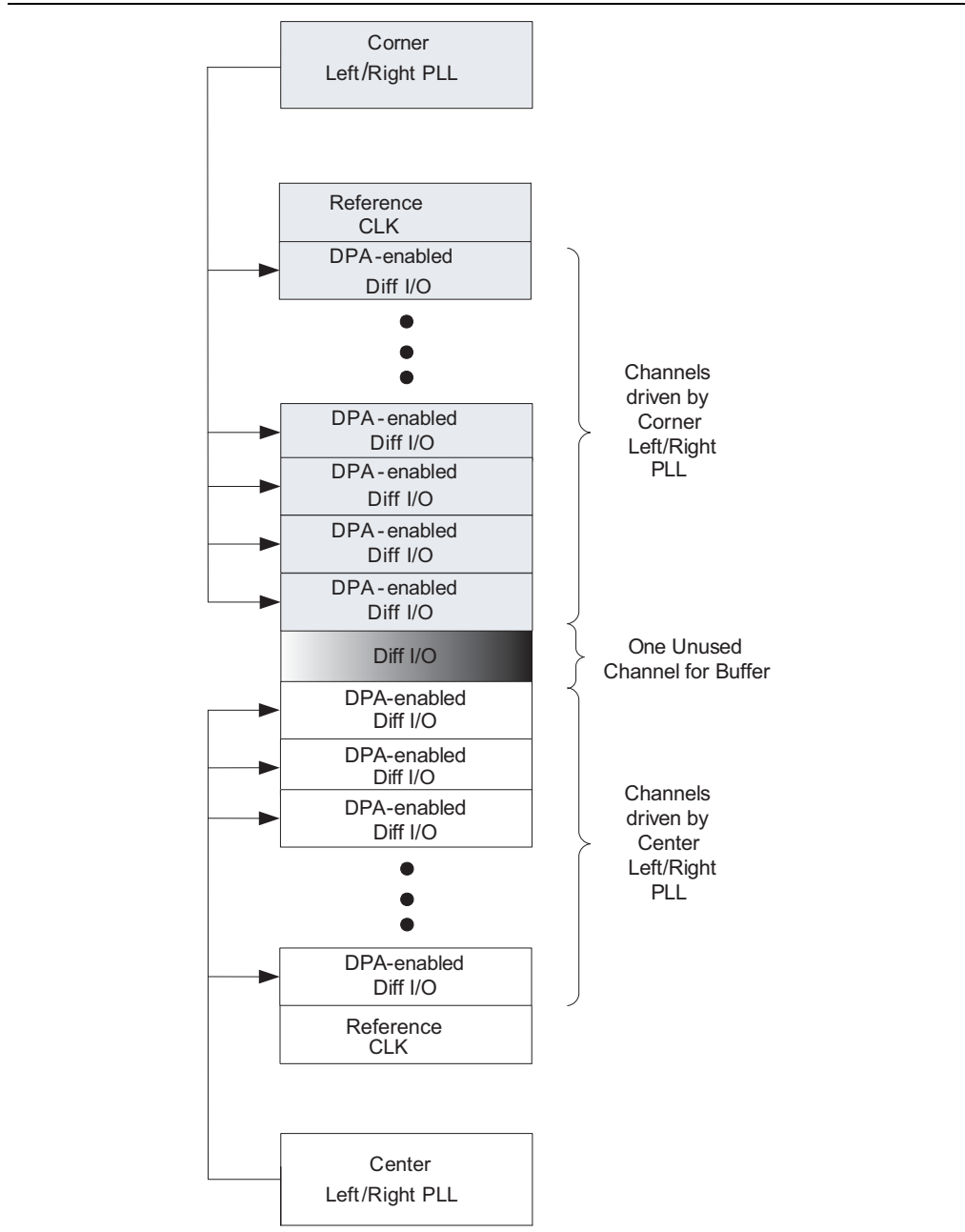

Using Both Center Left/Right PLLs

Both center left/right PLLs can be used to drive DPA-enabled channels simultaneously, as long as they drive these channels in their adjacent banks only, as shown in Figure 9-19.

If one of the center left/right PLLs drive the top and bottom banks, the other center left/right PLL cannot be used to drive the differential channels, as shown in Figure 9-19.

If the top PLL_L2/PLL_R2 drives DPA-enabled channels in the lower differential bank, the PLL_L3/PLL_R3 cannot drive DPA-enabled channels in the upper differential banks and vice versa. In other words, the center left/right PLLs cannot drive cross-banks simultaneously, as shown in Figure 9-20.

Figure 9-19. Center Left/Right PLLs Driving DPA-Enabled Differential I/Os

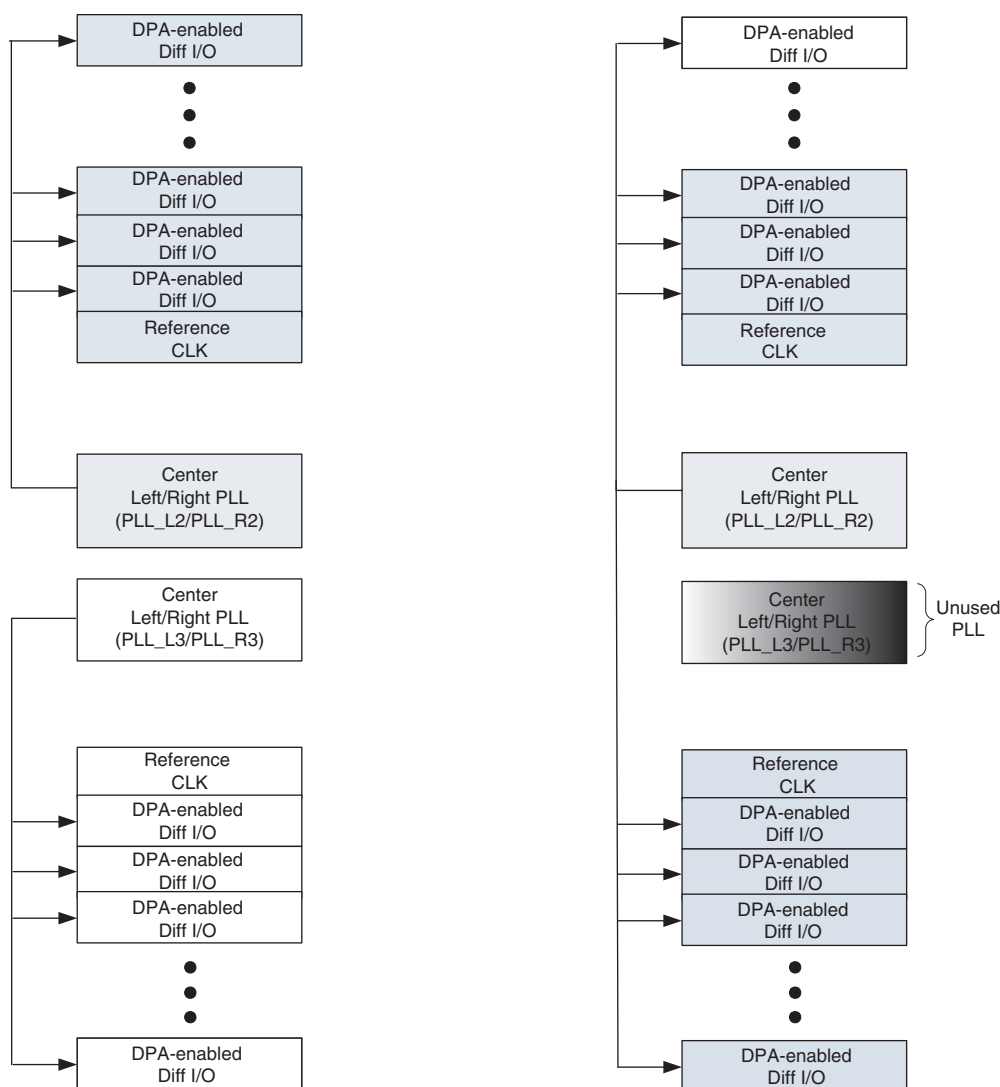
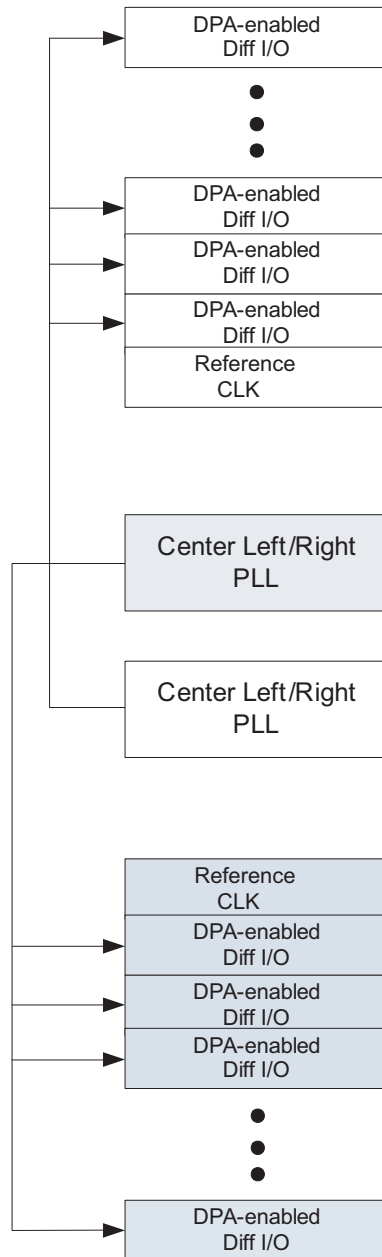

Figure 9-20. Invalid Placement of DPA-Enabled Differential I/Os Driven by Both Center Left/Right PLLs



Guidelines for DPA-Disabled Differential Channels

When DPA-disabled channels are used in the left and right banks of a Stratix III device, you must adhere to the guidelines in the following sections.

DPA-Disabled Channels and Single-Ended I/Os

The placement rules for DPA-disabled channels and single-ended I/Os are the same as those for DPA-enabled channels and single-ended I/Os.

DPA-Disabled Channel Driving Distance

Each left/right PLL can drive all the DPA-disabled channels in the entire bank.

Using Corner and Center Left/Right PLLs

A corner left/right PLL can be used to drive all transmitter channels and a center left/right PLL can be used to drive all DPA-disabled receiver channels within the same differential bank. In other words, a transmitter channel and a receiver channel in the same LAB row can be driven by two different PLLs, as shown in [Figure 9-21](#).

A corner left/right PLL and a center left/right PLL can drive duplex channels in the same differential bank as long as the channels driven by each PLL are not interleaved. No separation is necessary between the group of channels driven by the corner and center left/right PLLs. Refer to [Figure 9-21](#) and [Figure 9-22](#).

Figure 9-21. Corner and Center Left/Right PLLs Driving DPA-Disabled Differential I/Os in the Same Bank

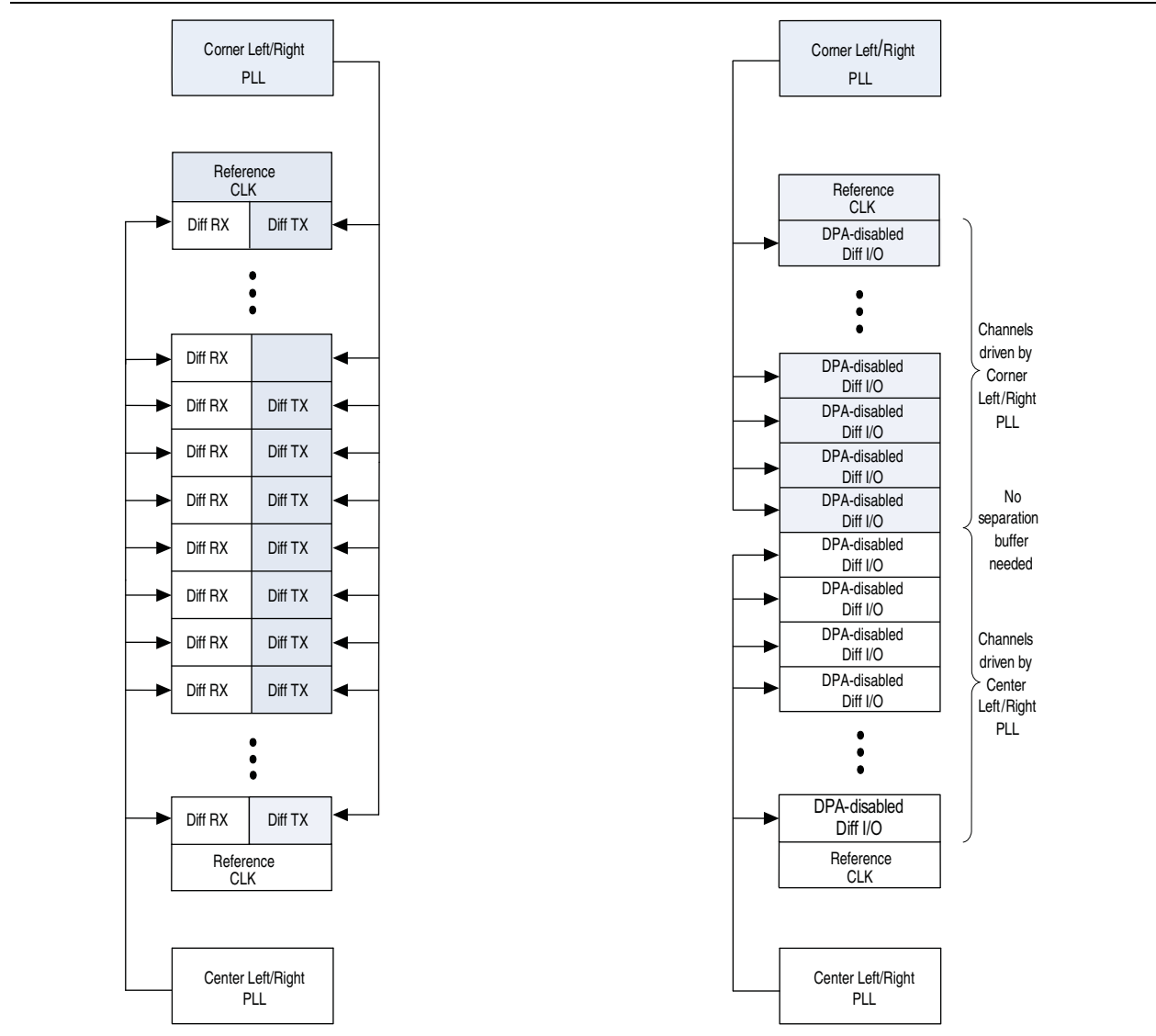

Using Both Center Left/Right PLLs

Both center left/right PLLs can be used simultaneously to drive DPA-disabled channels on upper and lower differential banks. Unlike DPA-enabled channels, the center left/right PLLs can drive cross-banks. For example, the upper center left/right PLL can drive the lower differential bank at the same time the lower center left/right PLL is driving the upper differential bank and vice versa, as shown in [Figure 9-23](#).

Figure 9-23. Both Center Left/Right PLLs Driving Cross-Bank DPA-Disabled Channels Simultaneously

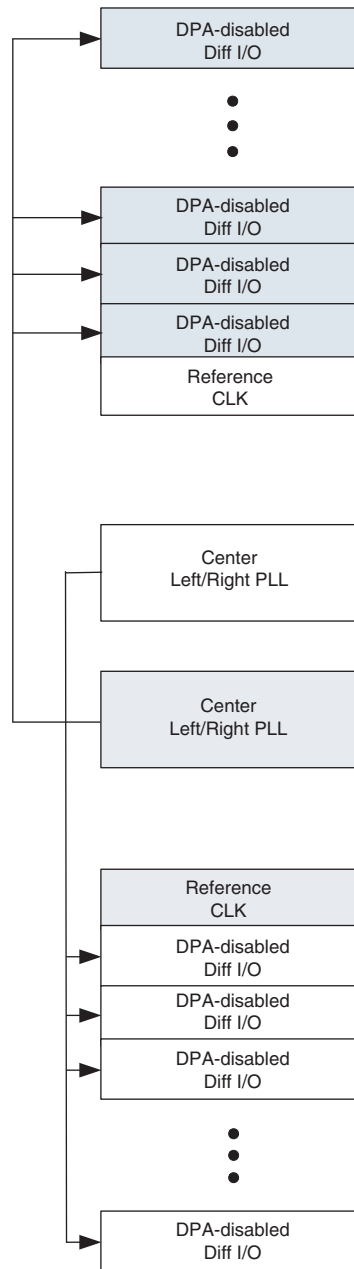

Chapter Revision History

Table 9-4 lists the revision history for this chapter.

Table 9-4. Chapter Revision History

Date	Revision	Changes Made
July 2010	1.9	Updated “Differential Transmitter” and “Differential Receiver” sections.
March 2010	1.8	Updated for the Quartus II software version 9.1 SP2 release: <ul style="list-style-type: none"> ■ Updated “LVDS Channels”, “Differential Transmitter”, and “Differential Receiver” section. ■ Minor changes to the text.
May 2009	1.7	<ul style="list-style-type: none"> ■ Updated Table 9-1 and Table 9-2. ■ Updated Figure 9-5. ■ Updated “DPA-Enabled Channels and Single-Ended I/Os” section.
February 2009	1.6	<ul style="list-style-type: none"> ■ Updated “DPA-Enabled Channels and Single-Ended I/Os” section. ■ Updated Table 9-2. ■ Removed “Reference Documents” section.
October 2008	1.5	<ul style="list-style-type: none"> ■ Updated “Introduction”, “Differential Receiver”, and “Synchronizer” sections. ■ Updated Figure 9-5. ■ Updated New Document Format.
May 2008	1.4	<ul style="list-style-type: none"> ■ Updated “Soft-CDR Mode”, “Dynamic Phase Aligner (DPA)”, “Programmable Pre-Emphasis and Programmable VOD”, and “Guidelines for DPA-Enabled Differential Channels” sections. ■ Updated Table 9-1 and Table 9-2. ■ Removed “Figure 9-19. Left/Right PLL Driving Distance for DPA-Enabled Channels”.
November 2007	1.3	<ul style="list-style-type: none"> ■ Updated Table 9-1 and Table 9-2.
October 2007	1.2	<ul style="list-style-type: none"> ■ Added material to “DPA-Enabled Channels and Single-Ended I/Os” on page 9-21 and removed material from “DPA-Disabled Channels and Single-Ended I/Os” on page 9-29. ■ Added new sections “Programmable Pre-Emphasis and Programmable VOD” on page 9-12, “Soft-CDR Mode”, and “Referenced Documents”. ■ Added live links for references. ■ Added Figure 9-10. ■ Minor edits to “DPA-Enabled Channel Driving Distance” section.
May 2007	1.1	<ul style="list-style-type: none"> ■ Minor changes to second paragraph of the section “Differential I/O Termination”. ■ Added Table 9-1 and Table 9-2.
November 2006	1.0	Initial release.

