

NOTES:

1. ALL Z STACK UP HEIGHT ESTIMATES ARE BASED ON PRE SMT BALL HEIGHT.
2. MARK KEEP-IN ZONE. NO COMPONENTS ALLOWED.
3. NOMINAL PACKAGE MASS ESTIMATE = 33.072g. ACTUAL MASS MAY VARY DUE TO MANUFACTURING PROCESS.
4. LAND-SIDE COMPONENT KEEP-IN ZONE.

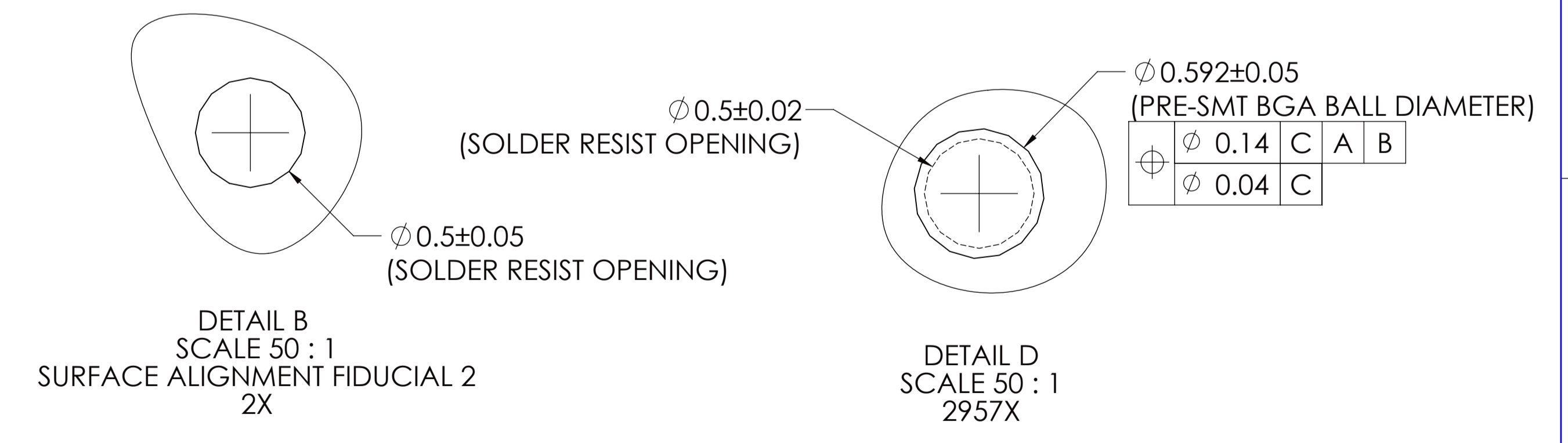
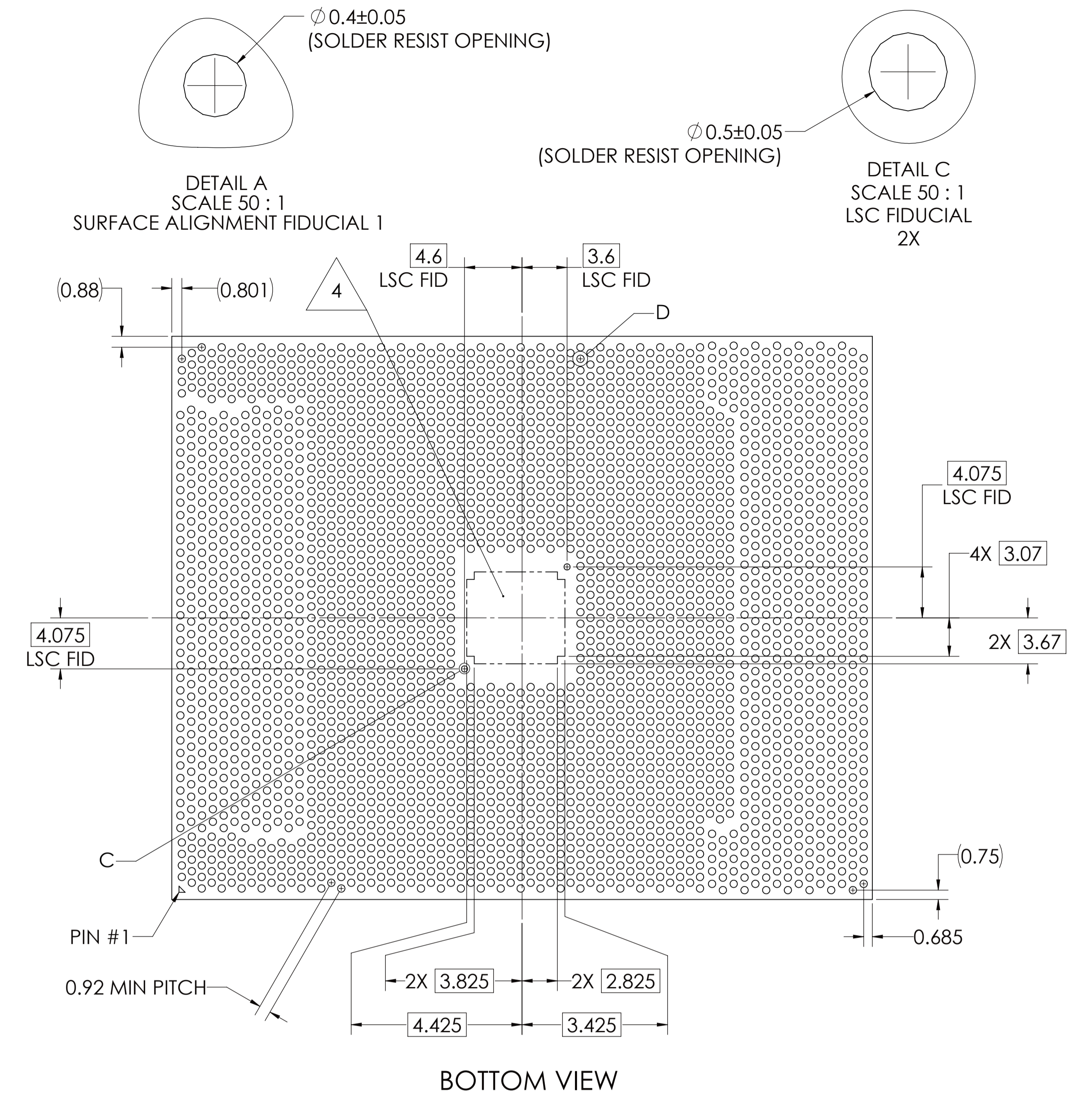
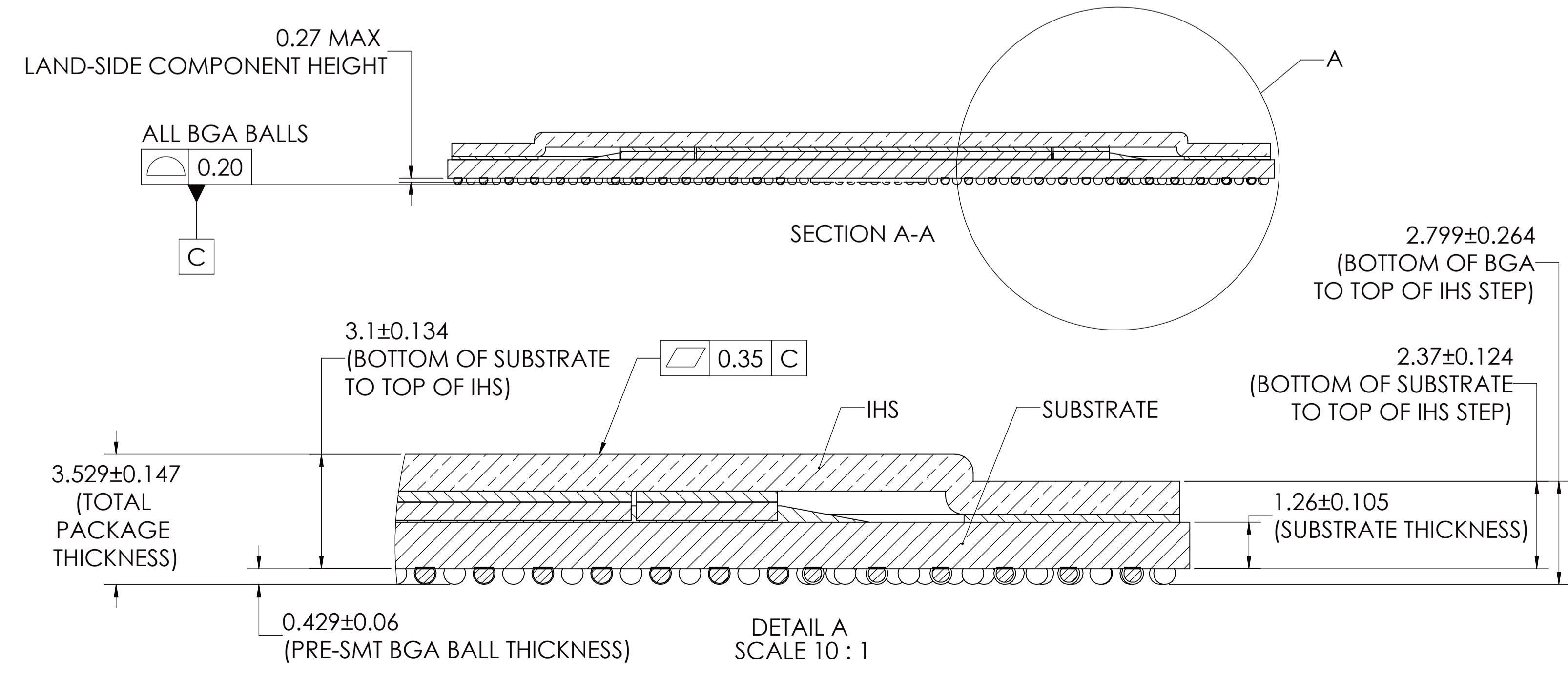
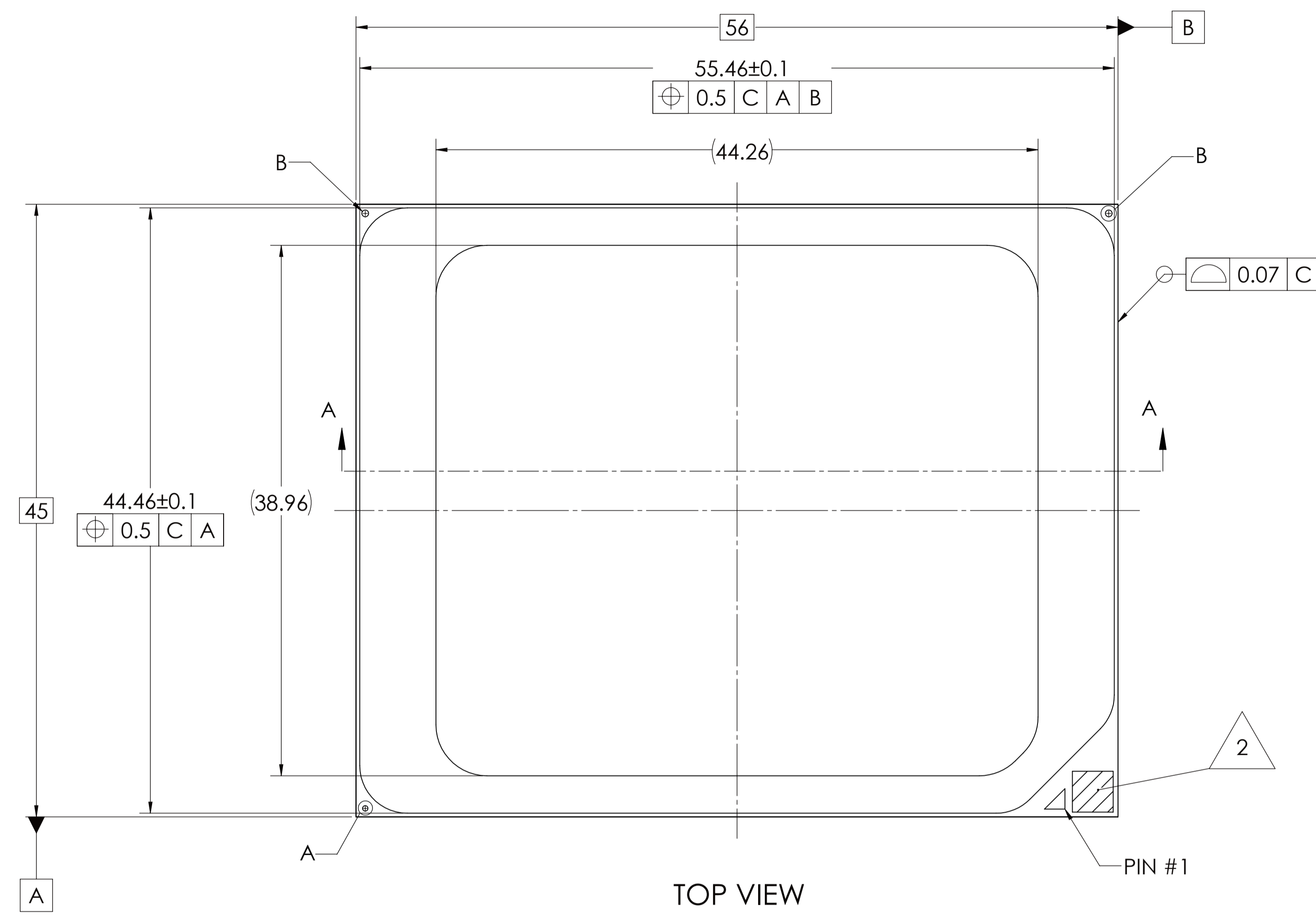

UNLESS OTHERWISE SPECIFIED: DIMENSIONS ARE IN MILLIMETERS. INTERPRET DIMENSIONS AND TOLERANCES PER ASME Y14.5-2009.	DESIGNED BY	DATE	DEPARTMENT	 2200 MISSION COLLEGE BLVD. P.O. BOX 58119 SANTA CLARA, CA 95052-8119
	DRAWN BY	DATE	TITLE	
	CHECKED BY	DATE	PACKAGE MECHANICAL DRAWING	
	APPROVED BY	DATE	56mm X 45mm, 2957 BALLS	
MATERIAL:	THIRD ANGLE PROJECTION		SIZE	DRAWING NUMBER
FINISH: SEE NOTES			A1	M97423
			SCALE: 4:1	DO NOT SCALE DRAWING
			SHEET 1 OF 2	

8

7

6

5

4

3

1

ZONE	REV	DESCRIPTION	DATE	APPR.
-	1	PRELIMINARY RELEASE	09/26/2022	C JAVIER
SH1, B4	2	UPDATED BOTTOM OF SUBSTRATE TO TOP OF IHS STEP DIMENSION TOLERANCE TO $\pm 0.124\text{mm}$	10/28/2022	CJAVIER
-	3	REMOVED PRELIMINARY FLAG NOTE	9/29/2023	S MCKINNEY

8

7

6

5

4

3

2

1

H
G
F
E
D
C
B
A

H
G
F
E
D
C
B
A