

NOTES:

1. ALL TOLERANCES ARE RSS (4 SIGMA).
2. ALL Z STACK UP HEIGHT ESTIMATES ARE BASED ON PRE SMT BALL HEIGHT.
3. MARK KEEP IN ZONE, NO COMPONENTS ALLOWED.
4. NOMINAL PACKAGE MASS ESTIMATE = 33.21g. ACTUAL WEIGHT MAY VARY DUE TO MANUFACTURING PROCESS.
5. ALL Z-HEIGHT RELATED DIMENSIONS ARE BASED ON LIMITED SAMPLING DATA.
6. LAND SIDE COMPONENT KEEP IN ZONE.

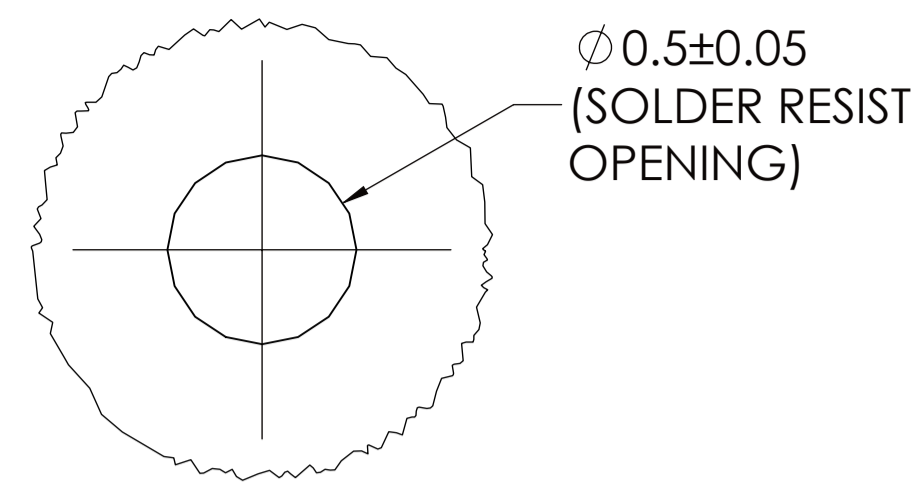

DETAIL B
SCALE 50 : 1
SURFACE ALIGNMENT FIDUCIAL 1
2X

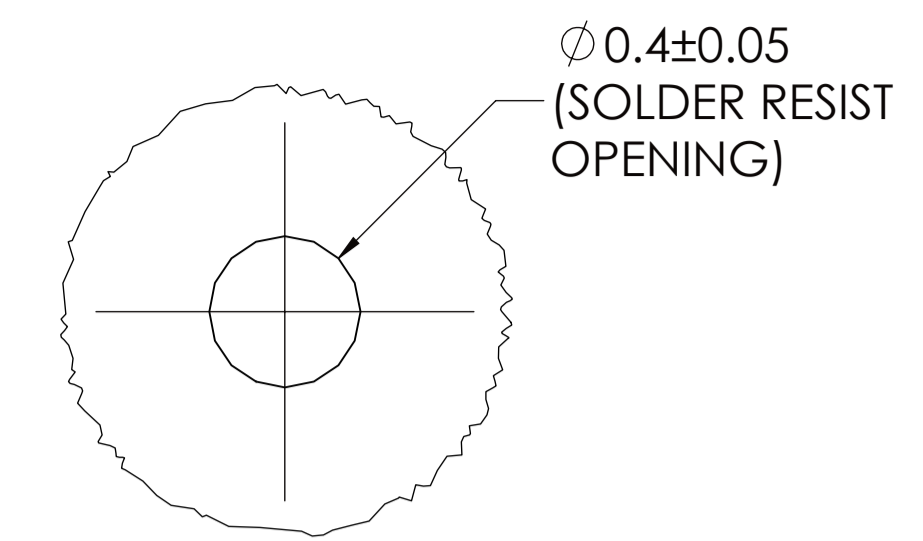

DETAIL C
SCALE 50 : 1
SURFACE ALIGNMENT FIDUCIAL 2

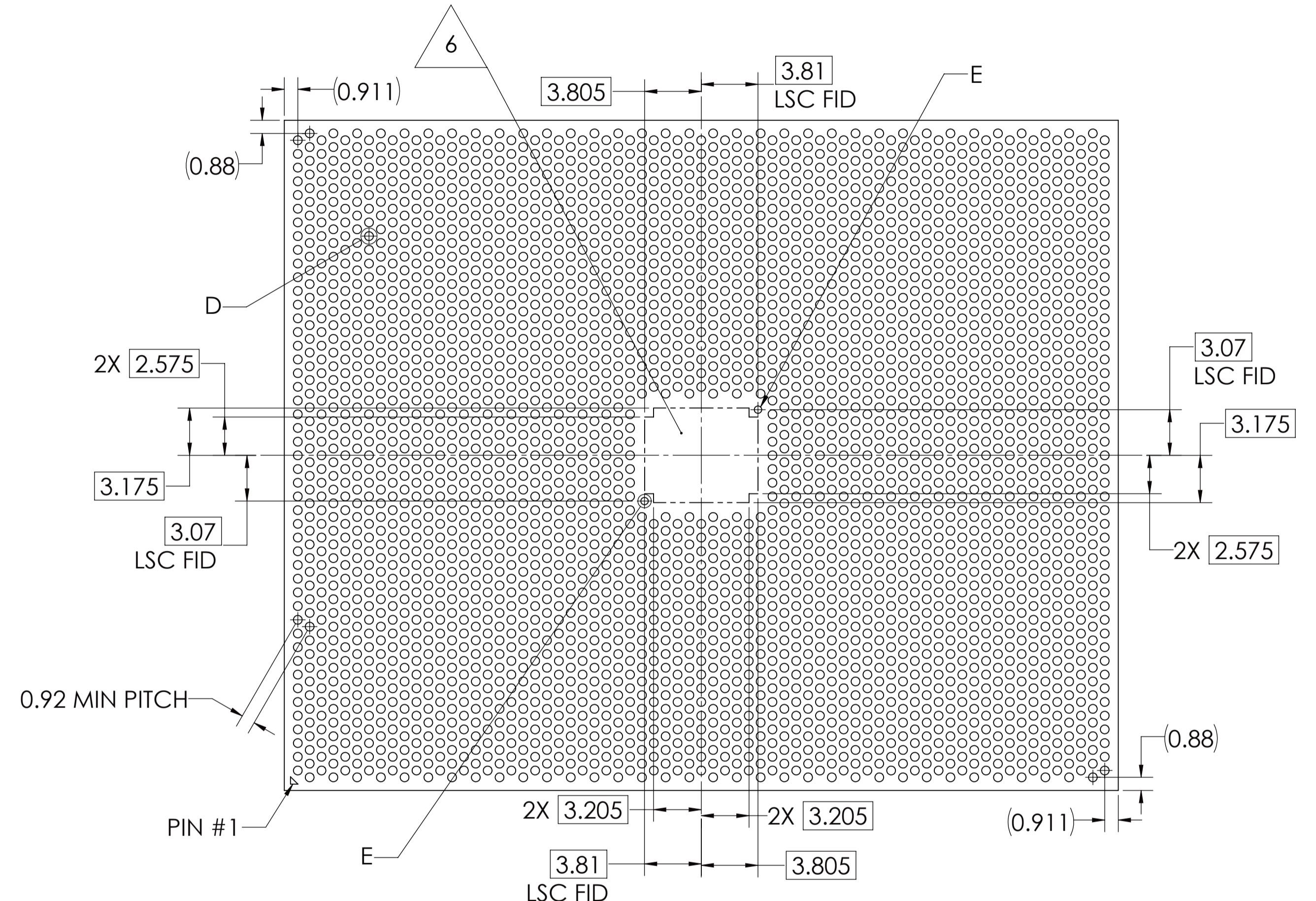

BOTTOM VIEW

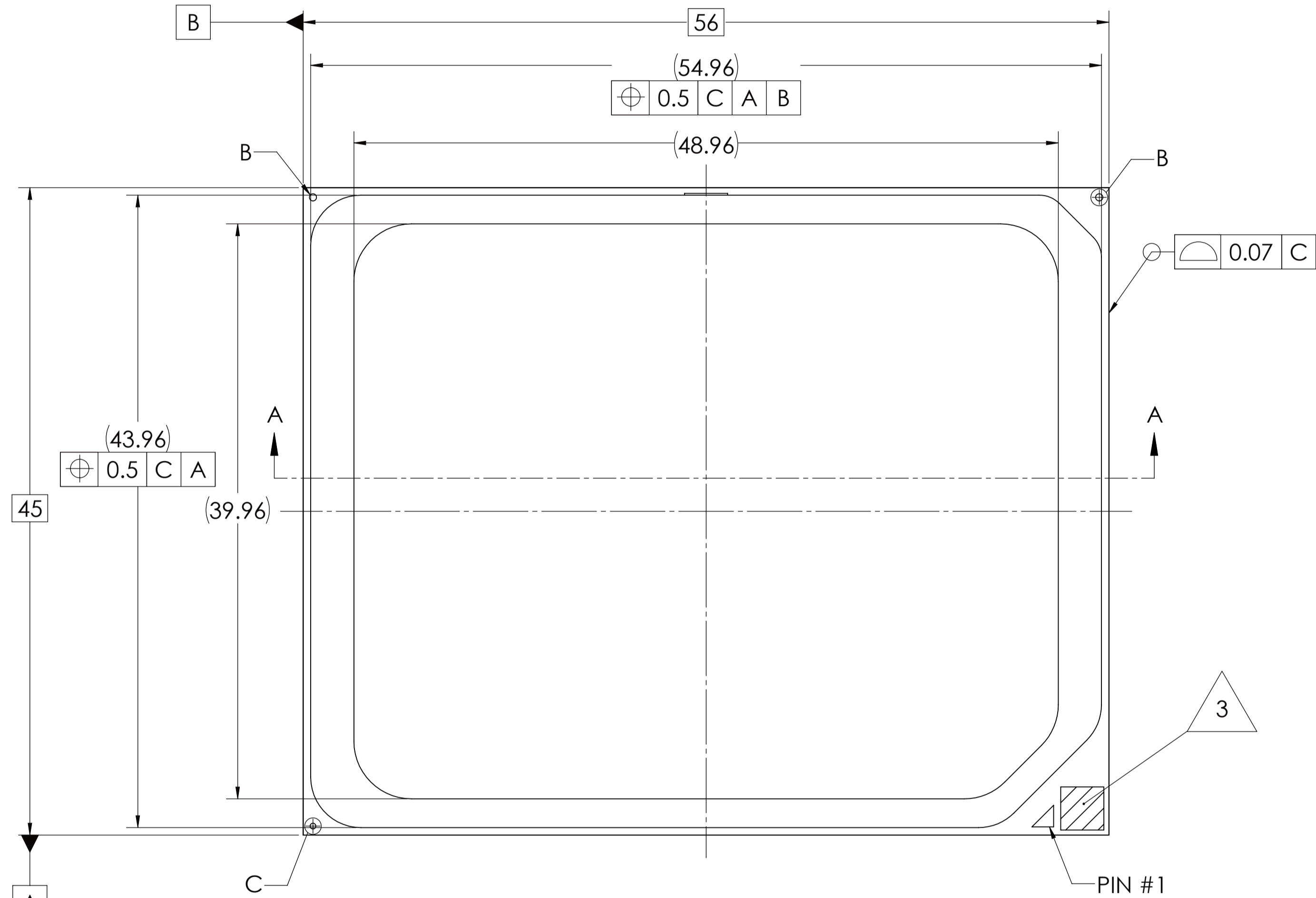

TOP VIEW

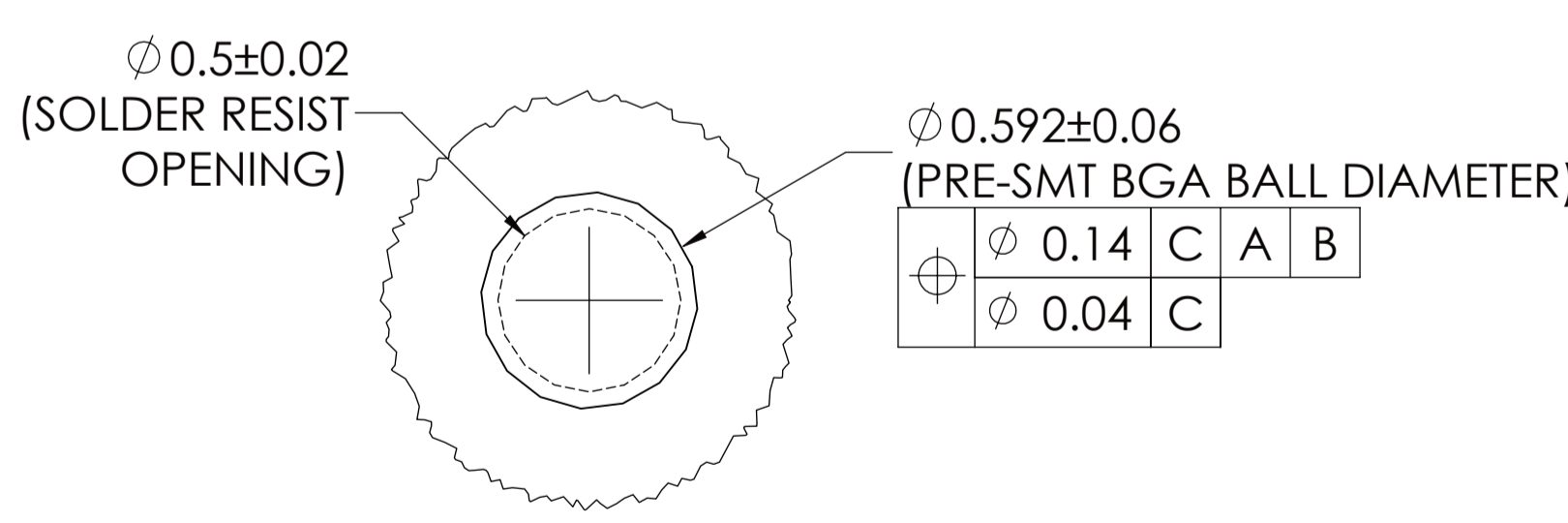

DETAIL D
SCALE 50 : 1
3184X

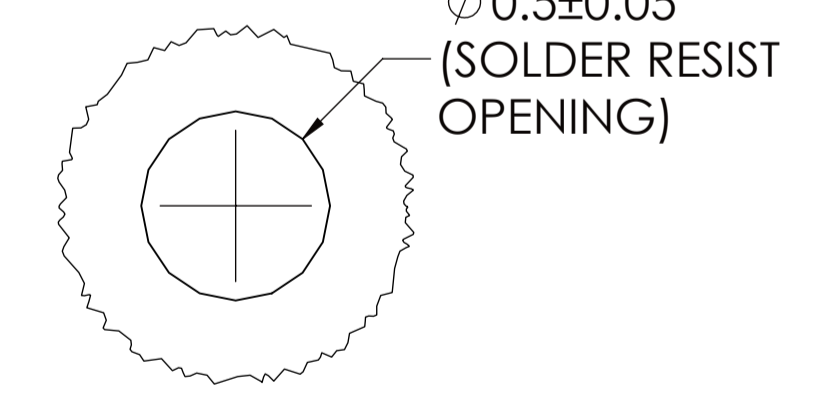

DETAIL E
SCALE 50 : 1
LSC FIDUCIAL
2X

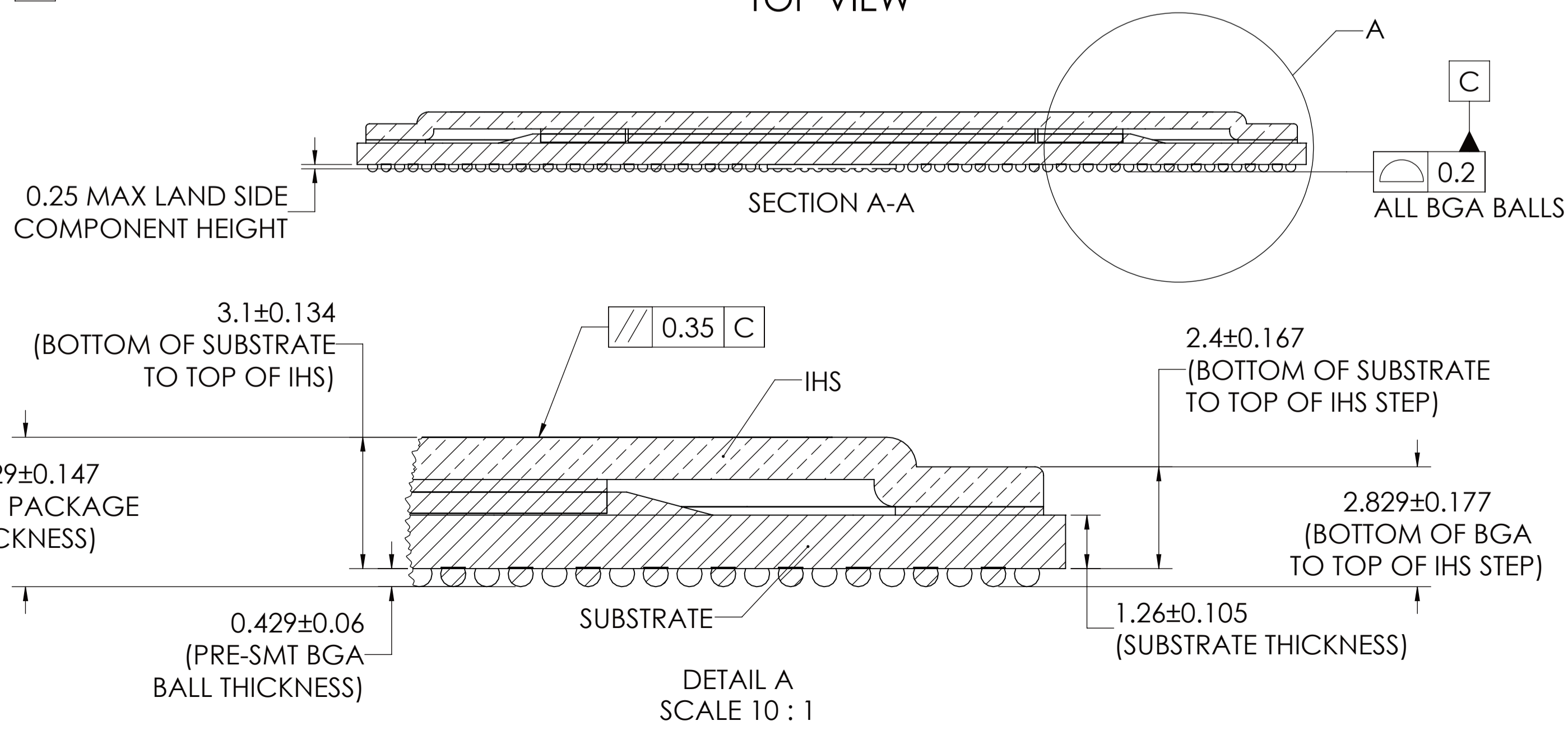

DETAIL A
SCALE 10 : 1

| | | | | |
|--|------------------------|------|--|--|
| UNLESS OTHERWISE SPECIFIED: DIMENSIONS ARE IN MILLIMETERS. INTERPRET DIMENSIONS AND TOLERANCES PER ASME Y14.5-2009. | DESIGNED BY | DATE | DEPARTMENT | 2200 MISSION COLLEGE BLVD. P.O. BOX 58119 SANTA CLARA, CA 95052-8119 |
| | DRAWN BY | DATE | TITLE | |
| | CHECKED BY | DATE | PACKAGE MECHANICAL DRAWING 56mm X 45mm, 5-2-5 12 LAYER STACKUP, 3184 BGA | |
| | APPROVED BY | DATE | SIZE: A1 DRAWING NUMBER: N21348 SCALE: 4:1 DO NOT SCALE DRAWING SHEET 1 OF 2 | |
| MATERIAL: | THIRD ANGLE PROJECTION | | REV | 03 |
| FINISH: SEE NOTES | | | | |

| ZONE | REV | DESCRIPTION | DATE | APPR. |
|--------|-----|-------------------------------|------------|-------|
| - | 1 | ENGINEERING RELEASE | 3/22/2023 | SM |
| SH1 B5 | 2 | UPDATED STACK UP TOLERANCES | 5/5/2023 | SM |
| | 3 | REMOVED PRELIMINARY FLAG NOTE | 11/16/2023 | AD |