

- NOTES:
1. ALL TOLERANCES ARE RSS (4 SIGMA).
 2. ALL Z STACK UP HEIGHT ESTIMATES ARE BASED ON PRE SMT BALL HEIGHT.
 3. MARK KEEP IN ZONE, NO COMPONENTS ALLOWED.
 4. NOMINAL PACKAGE MASS ESTIMATE = 24.3 GRAMS. ACTUAL WEIGHT MAY VARY DUE TO MANUFACTURING PROCESS.
 5. ALL Z-HEIGHT RELATED DIMENSIONS ARE BASED ON LIMITED SAMPLING DATA.
- △ LSC KIZ.

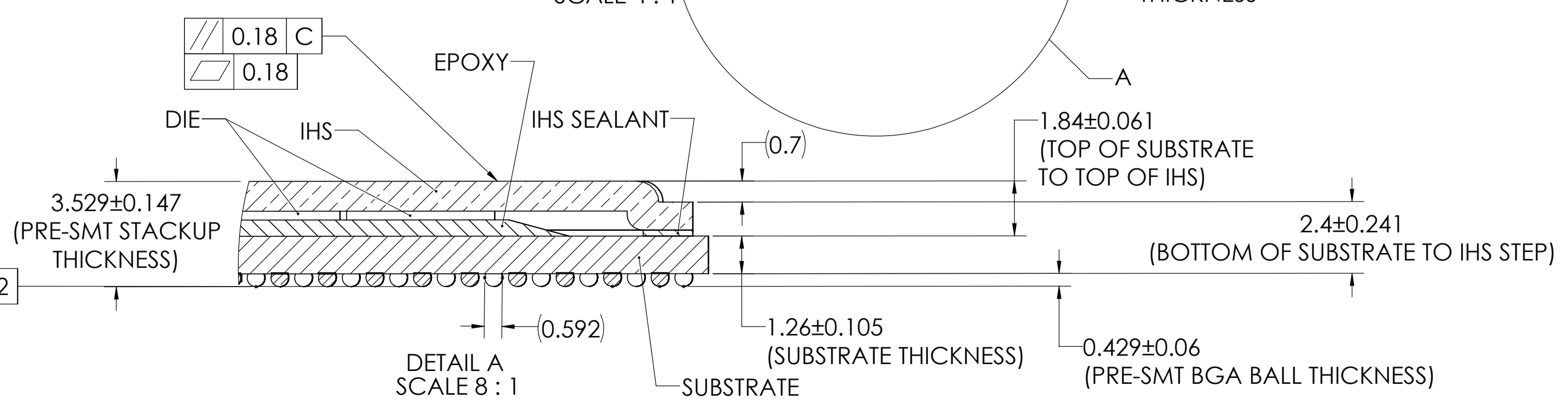
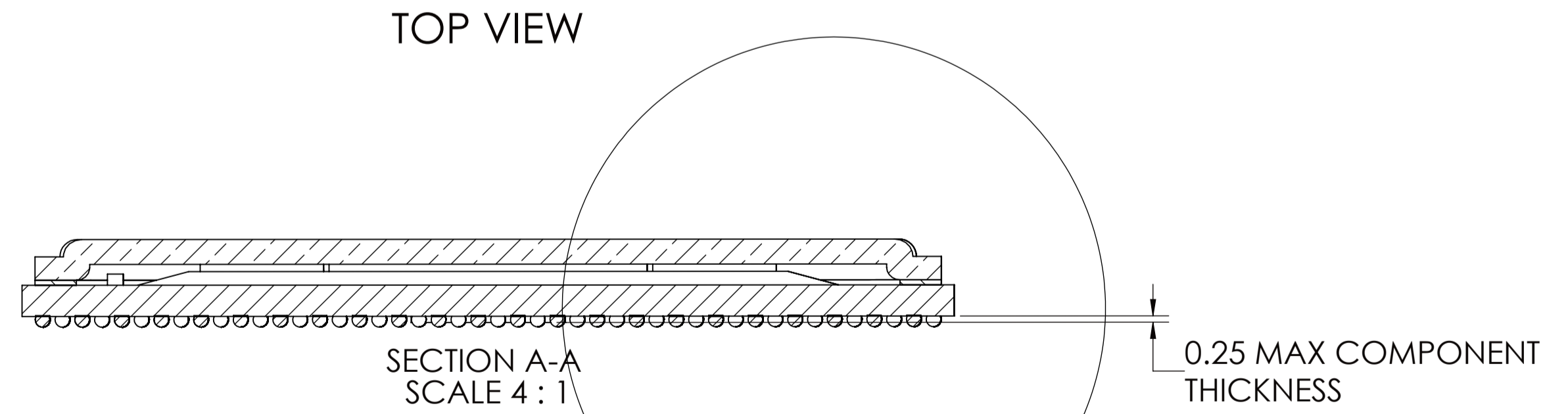
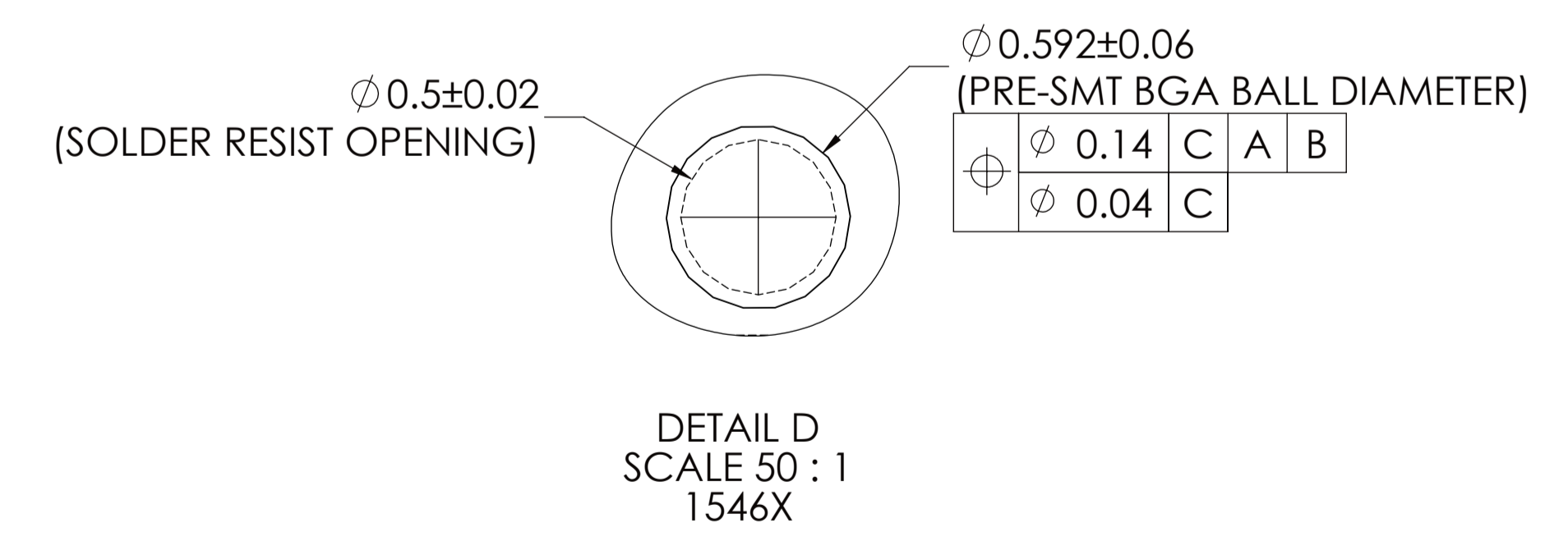
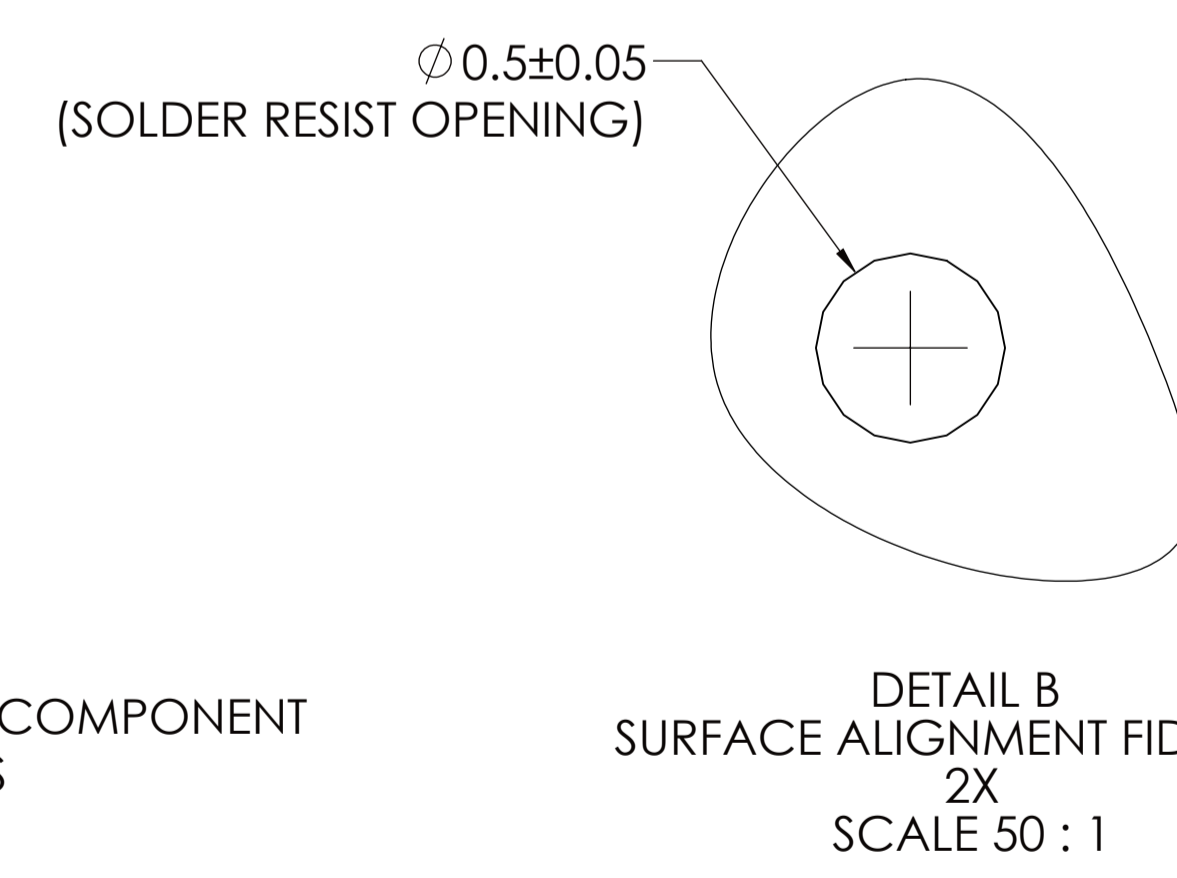
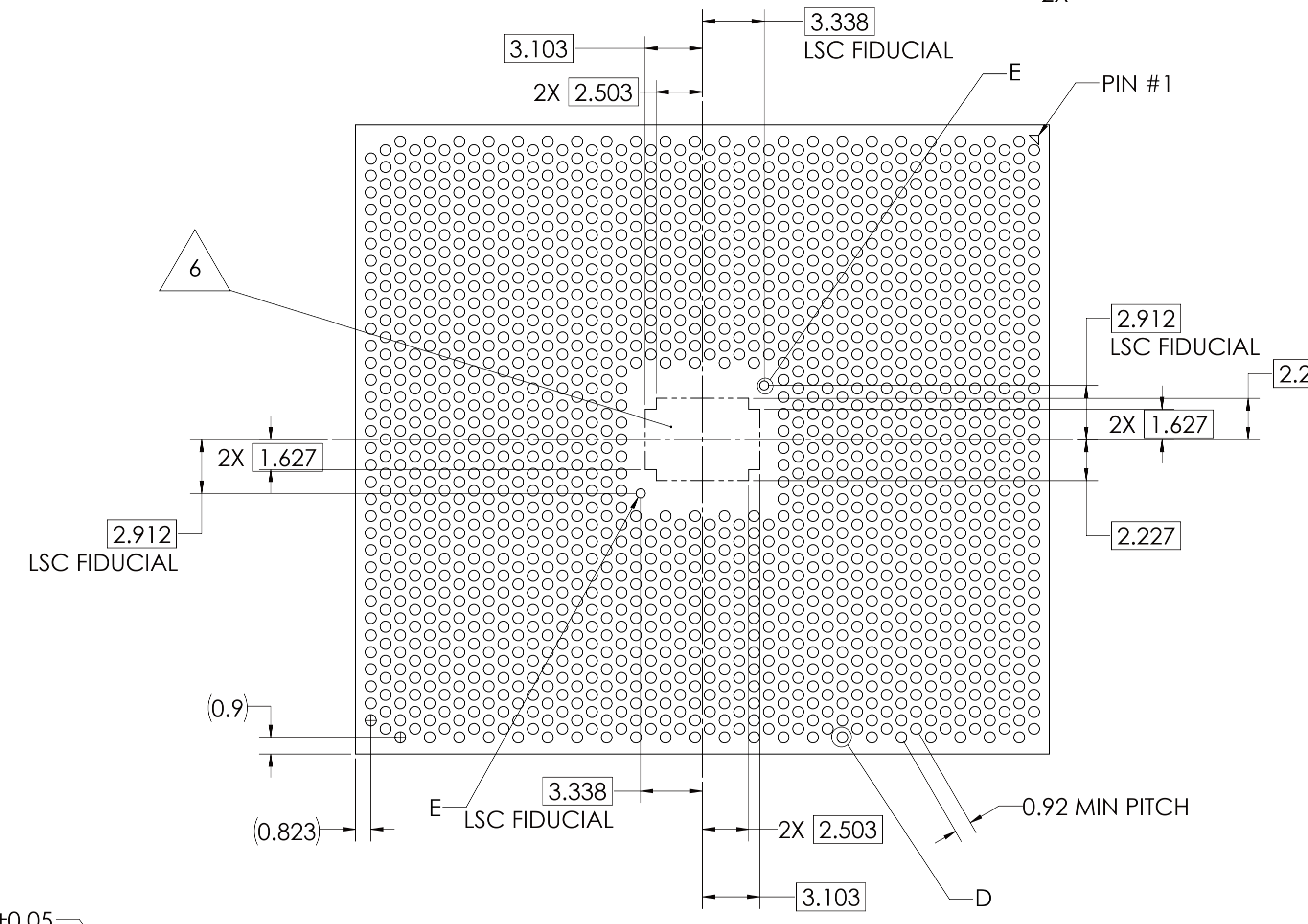
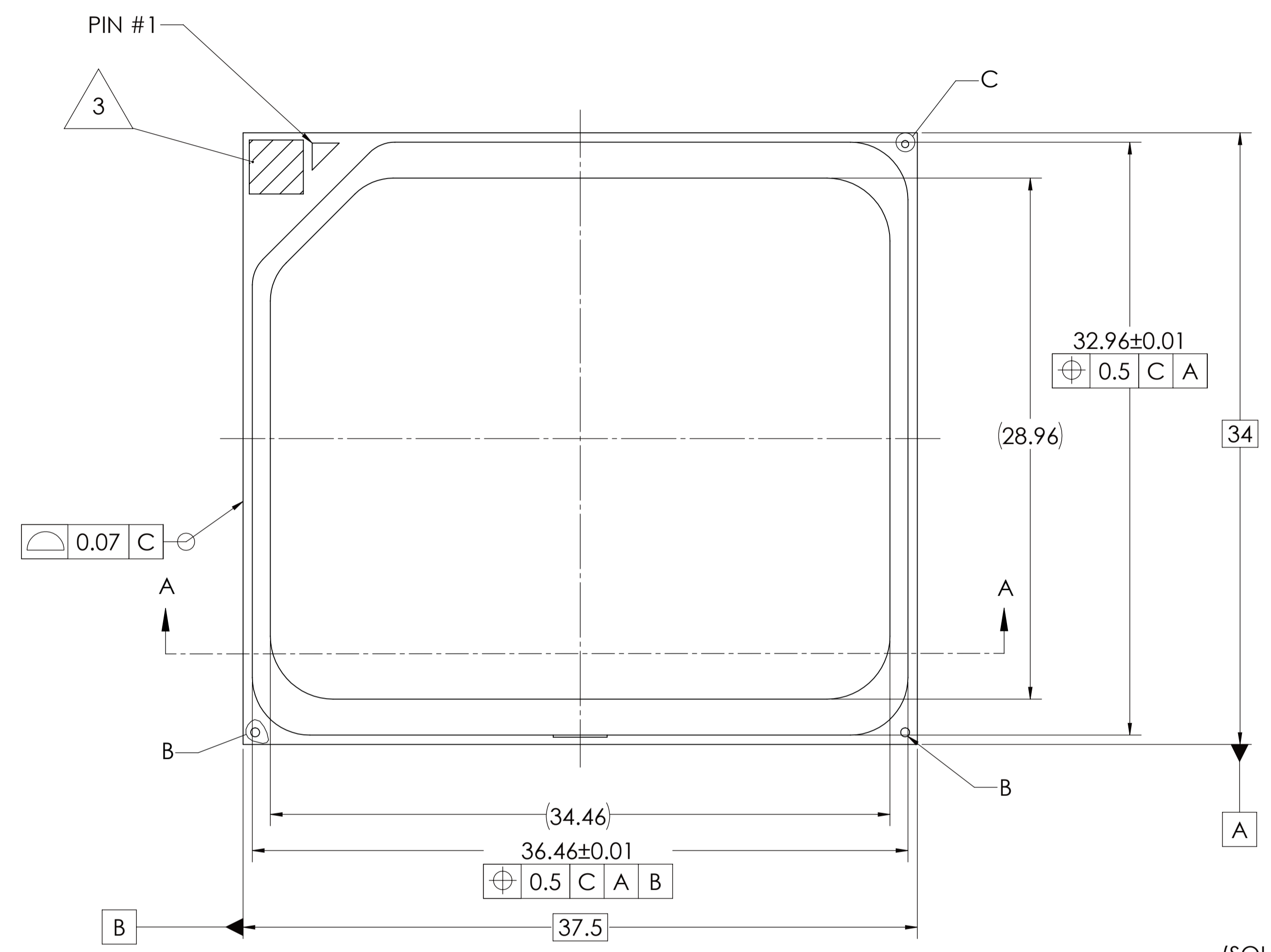
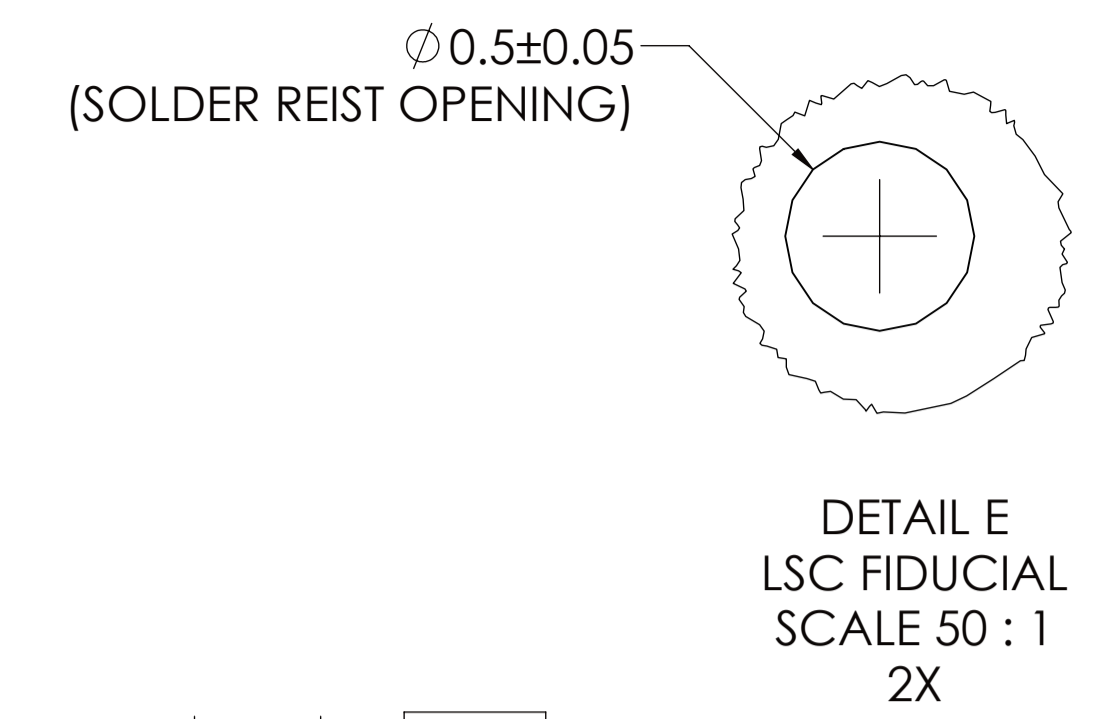
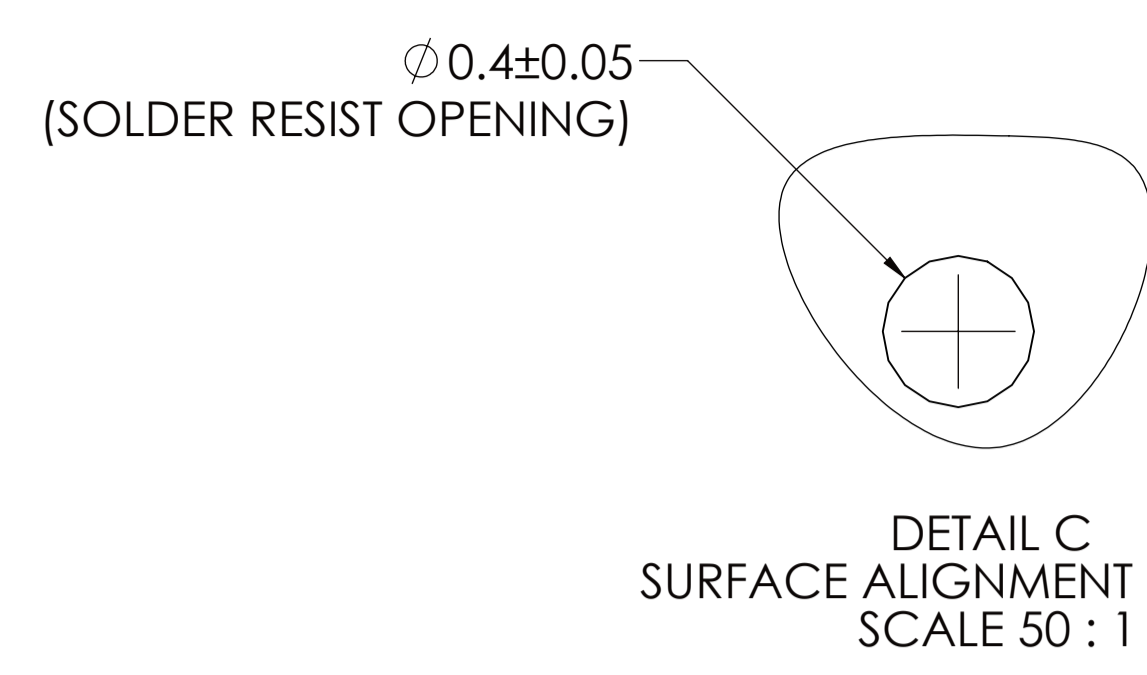

UNLESS OTHERWISE SPECIFIED: DIMENSIONS ARE IN MILLIMETERS. INTERPRET DIMENSIONS AND TOLERANCES PER ASME Y14.5-2009.	DESIGNED BY	DATE	DEPARTMENT	 2200 MISSION COLLEGE BLVD. P.O. BOX 58119 SANTA CLARA, CA 95052-8119
	DRAWN BY	DATE	TITLE	
	CHECKED BY	DATE	PACKAGE MECHANICAL DRAWING 37.5mm X 34mm, 5-2-5	
	APPROVED BY	DATE		
MATERIAL:	THIRD ANGLE PROJECTION			SIZE
FINISH: SEE NOTES				DRAWING NUMBER M61689
			SCALE: 5:1	DO NOT SCALE DRAWING
				SHEET 1 OF 2

8

7

6

5

4

3

1

DWG. NO. M61689 SH. 2 REV. 03

THIS DRAWING CONTAINS INTEL CORPORATION CONFIDENTIAL INFORMATION. IT IS DISCLOSED IN CONFIDENCE AND ITS CONTENTS MAY NOT BE DISCLOSED, REPRODUCED, DISPLAYED OR MODIFIED, WITHOUT THE PRIOR WRITTEN CONSENT OF INTEL CORPORATION.

H
G
F
E
D
C
B
A

H
G
F
E
D
C
B
A

ZONE	REV	DESCRIPTION	DATE	APPR.
-	1	PRELIMINARY RELEASE	9/30/2021	CE
SH1	2	UPDATED THE IHS TO BE CENTERED ON THE PACKAGE IN TOP VIEW, REMOVED POSITIONAL TOLERANCE FOR FIDS.	12/2/2021	AK
SH1	3	REDUCED COPLANARITY TO 200um, REMOVED ALL PRELIMINARY FLAG NOTES.	2/14/2023	JG

8

7

6

5

4

3

2

1