

NOTES:
 1. ALL TOLERANCES ARE RSS (4 SIGMA).
 2. ALL Z STACK UP HEIGHT ESTIMATES ARE BASED ON PRE SMT BALL HEIGHT.
 3. MARK KOZ, NO COMPONENTS ALLOWED.
 4. NOMINAL PACKAGE MASS ESTIMATE = 23.68 GRAMS. ACTUAL WEIGHT MAY VARY DUE TO MANUFACTURING PROCESS.
 5. ALL Z-HEIGHT RELATED DIMENSIONS ARE BASED ON LIMITED SAMPLING DATA.
 6. LSC KIZ.
 7. INCOMNG BALL SIZE 24mils

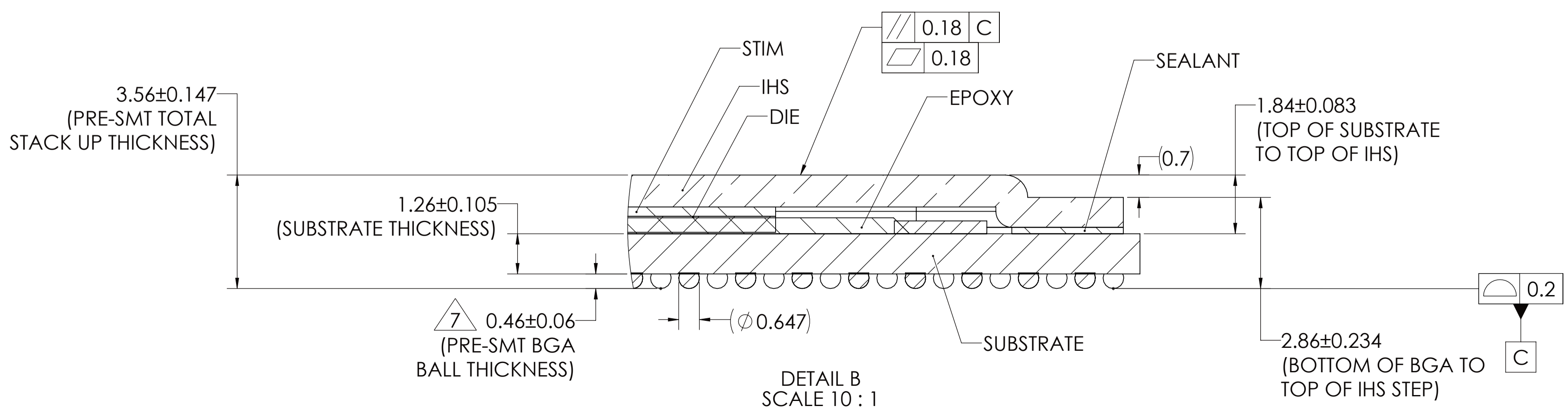
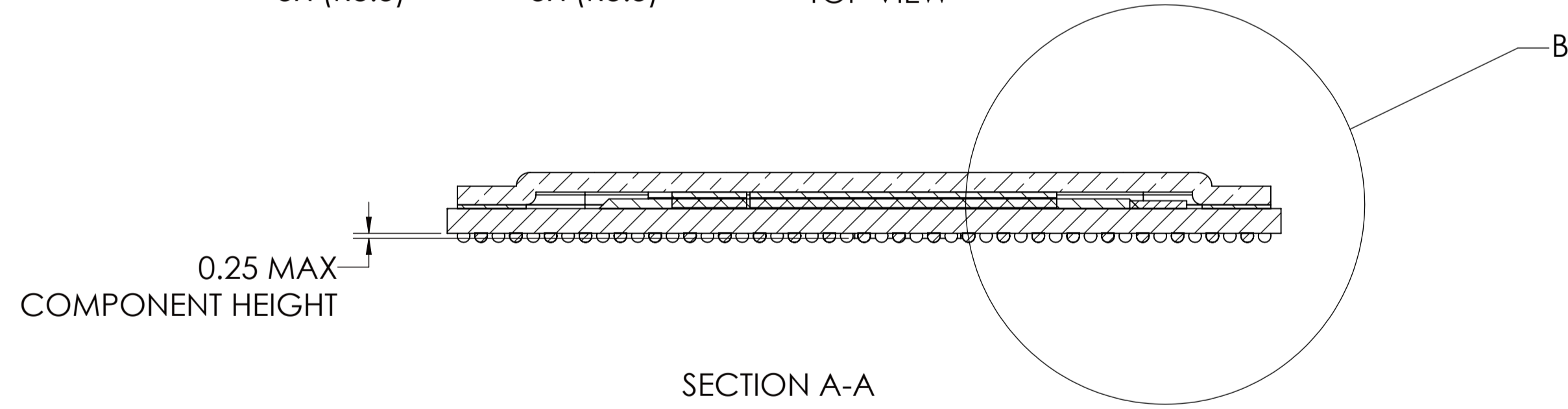
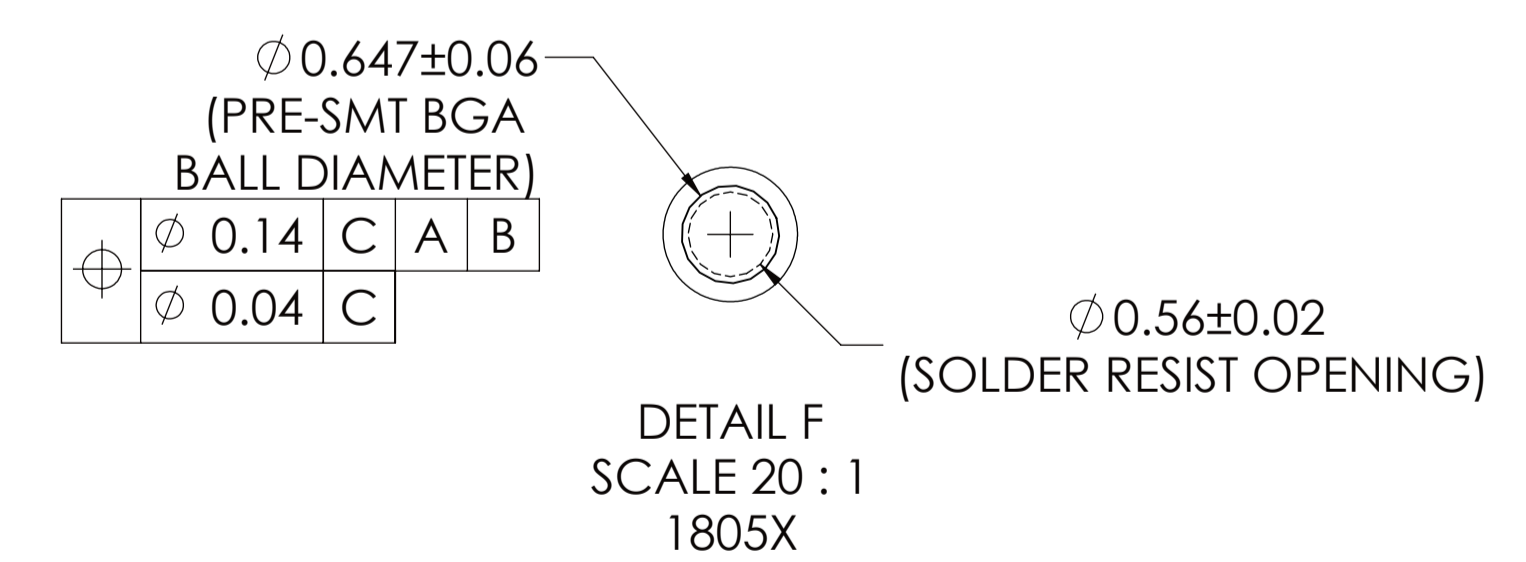
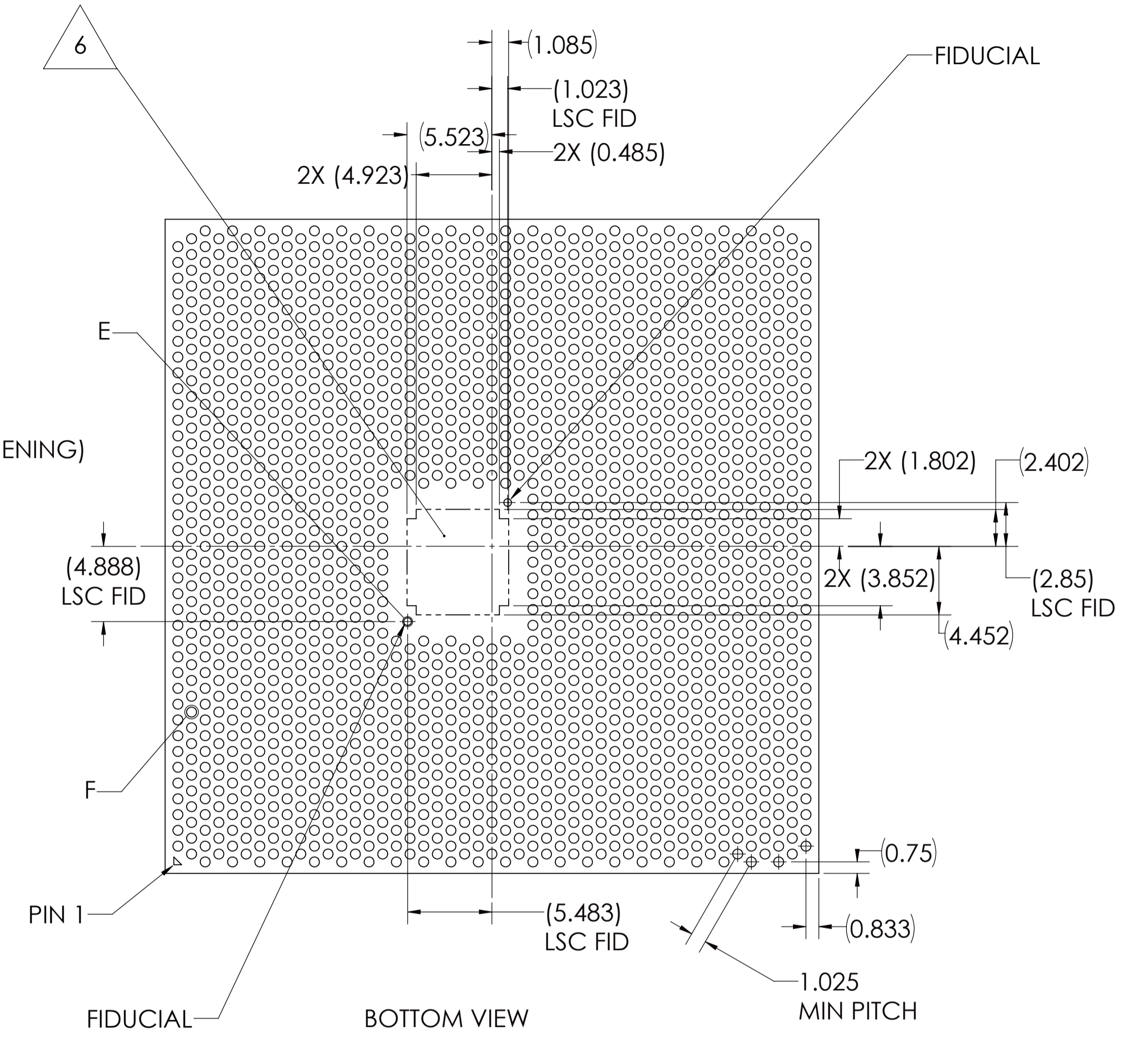
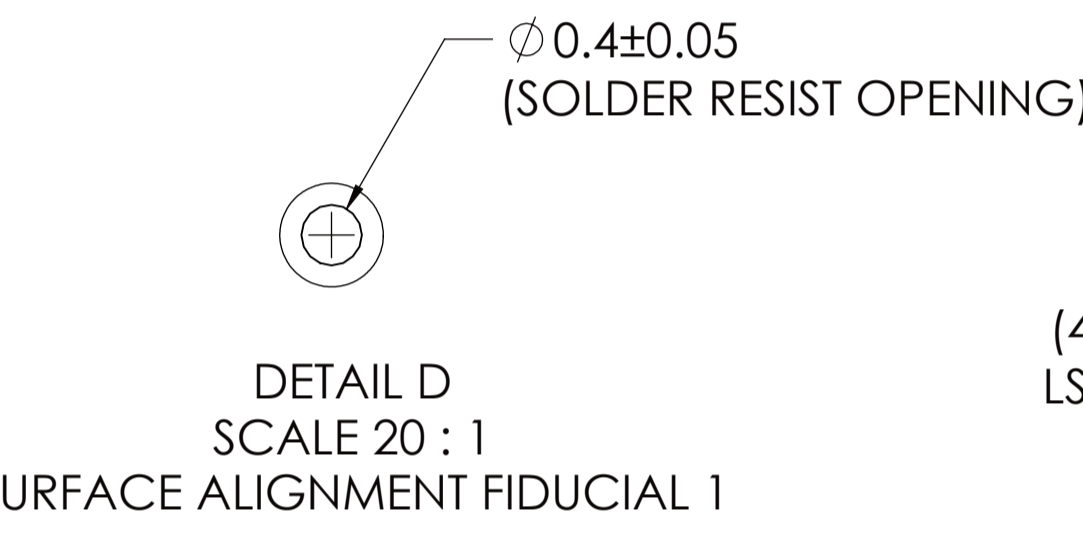
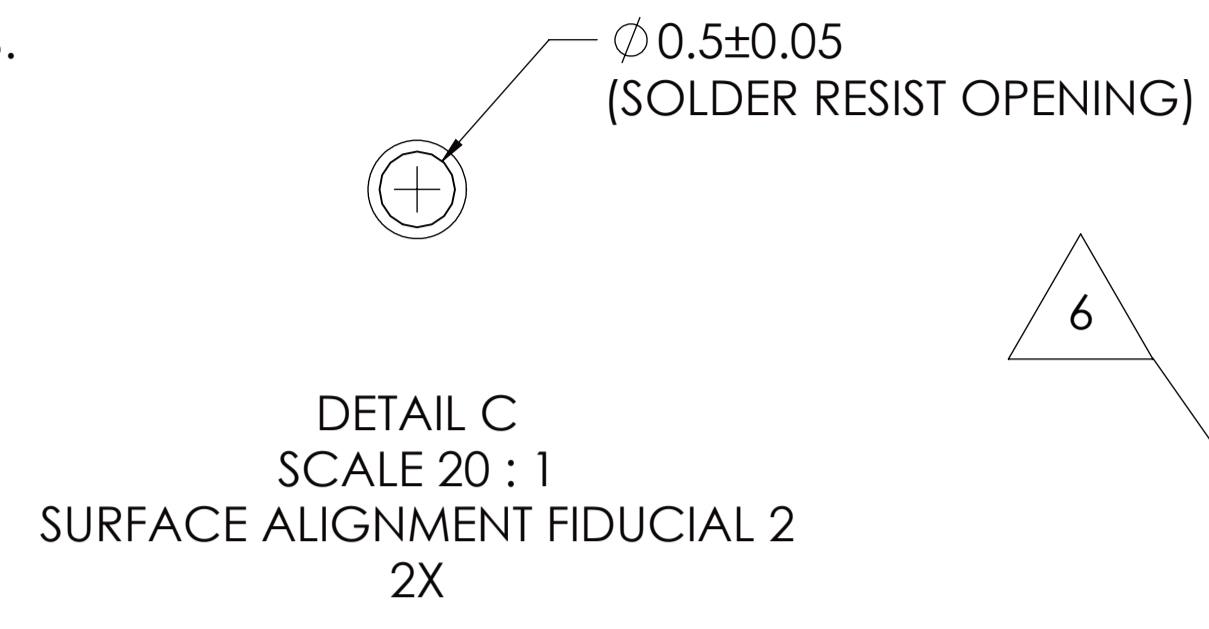
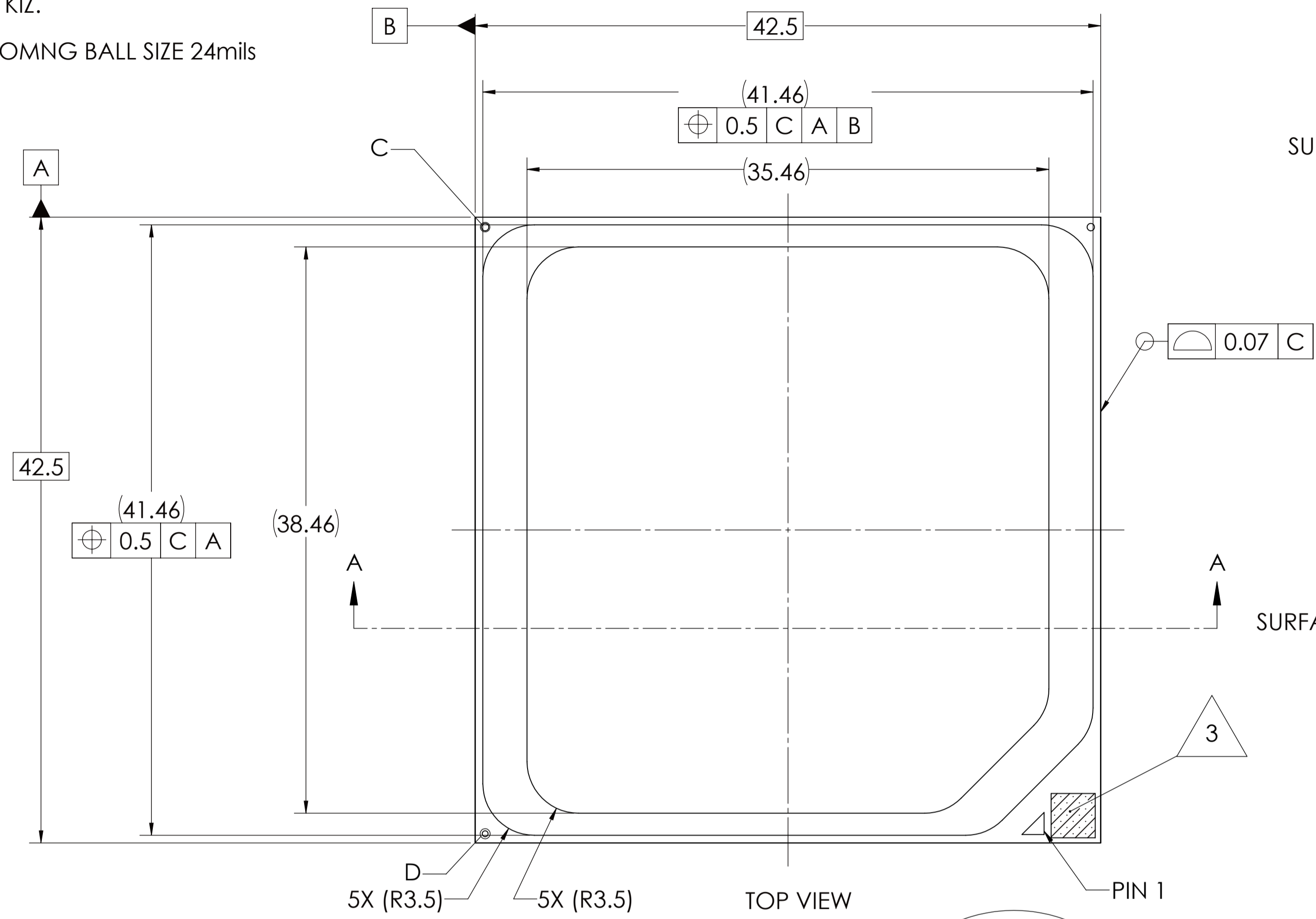

UNLESS OTHERWISE SPECIFIED: DIMENSIONS ARE IN MILLIMETERS. INTERPRET DIMENSIONS AND TOLERANCES PER ASME Y14.5-2009.	DESIGNED BY	DATE	DEPARTMENT	 2200 MISSION COLLEGE BLVD. P.O. BOX 58119 SANTA CLARA, CA 95052-8119
	DRAWN BY	DATE	TITLE	
	CHECKED BY	DATE	SIZE	
	APPROVED BY	DATE	DRAWING NUMBER	
MATERIAL:	THIRD ANGLE PROJECTION		REV	
SEE NOTES			A1	M67999
SCALE: 4:1			DO NOT SCALE DRAWING	SHEET 1 OF 2

8

7

6

5

4

3

1

DWG. NO. M67999 SH. 2 REV. 01

H
G
F
E
D
C
B
A

H
G
F
E
D
C
B
A

ZONE	REV	DESCRIPTION	DATE	APPR.
-	1	PRELIMINARY RELEASE	12/20/2021	AK
SH1	2	REDUCED COPLANARITY TO 200um. REMOVED ALL PRELIMINARY FLAG NOTES.	2/22/2023	JG

8

7

6

5

4

3

2

1