

NOTES:

1. ALL TOLERANCES ARE RSS (4 SIGMA).
2. ALL Z STACK UP HEIGHT ESTIMATES ARE BASED ON PRE SMT BALL HEIGHT.
3. MARK KEEP IN ZONE, NO COMPONENTS ALLOWED.
4. NOMINAL PACKAGE MASS ESTIMATE = 33.03 GRAMS. ACTUAL WEIGHT MAY VARY DUE TO MANUFACTURING PROCESS.
5. ALL Z-HEIGHT RELATED DIMENSIONS ARE BASED ON LIMITED SAMPLING DATA.
6. LAND SIDE COMPONENT KEEP IN ZONE.

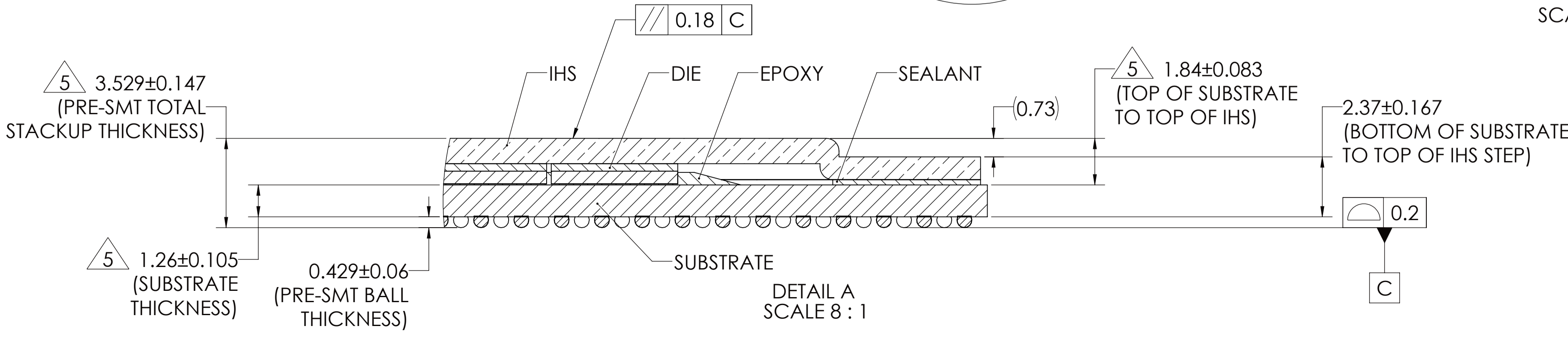
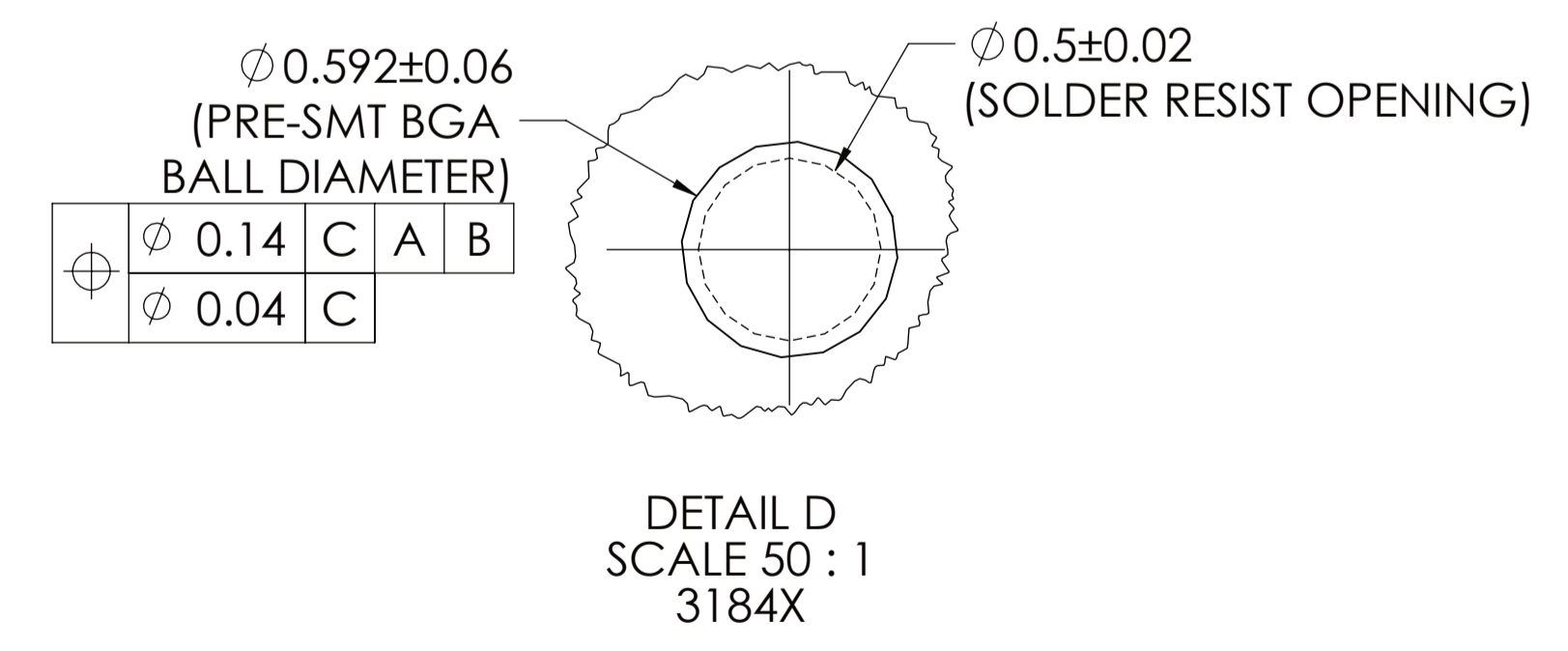
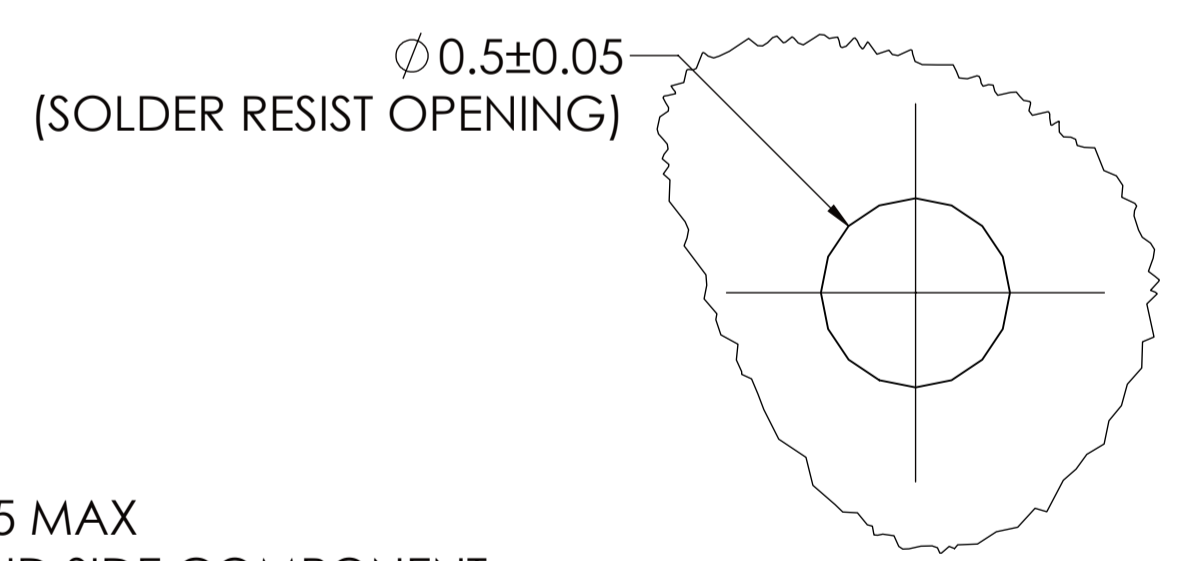
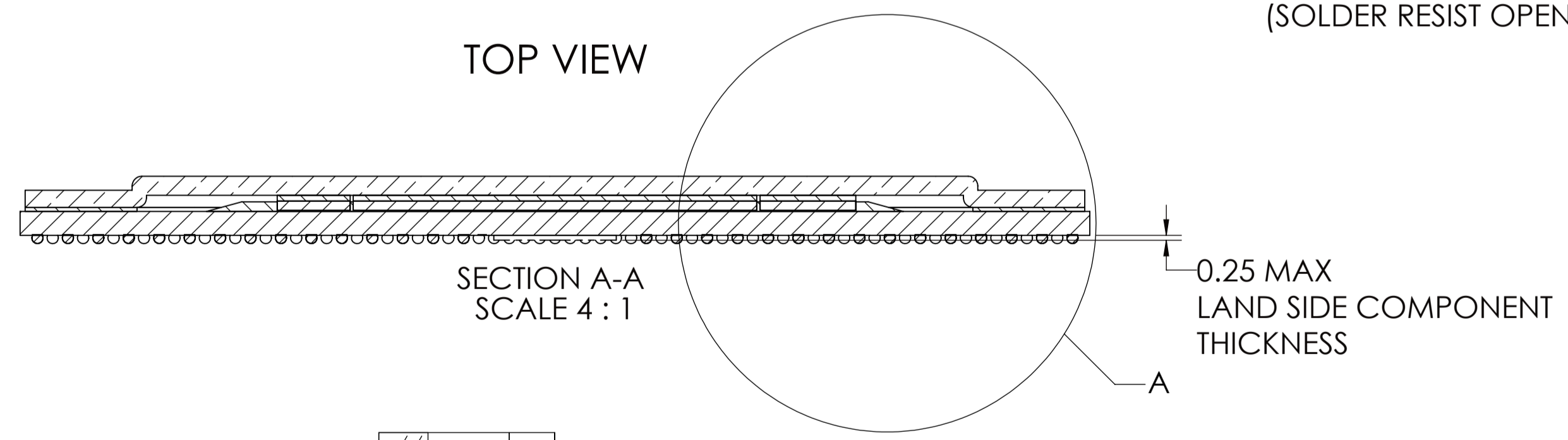
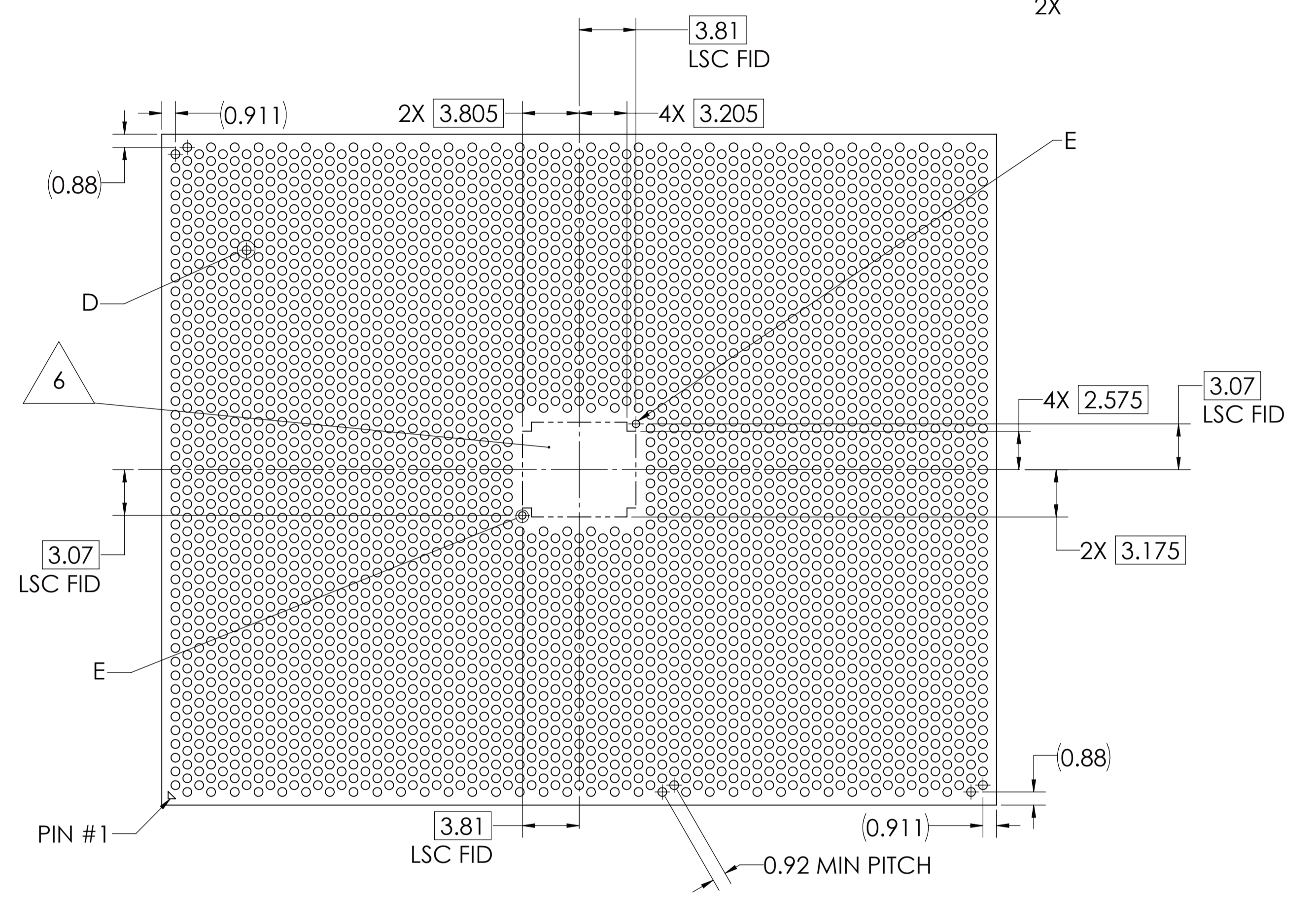
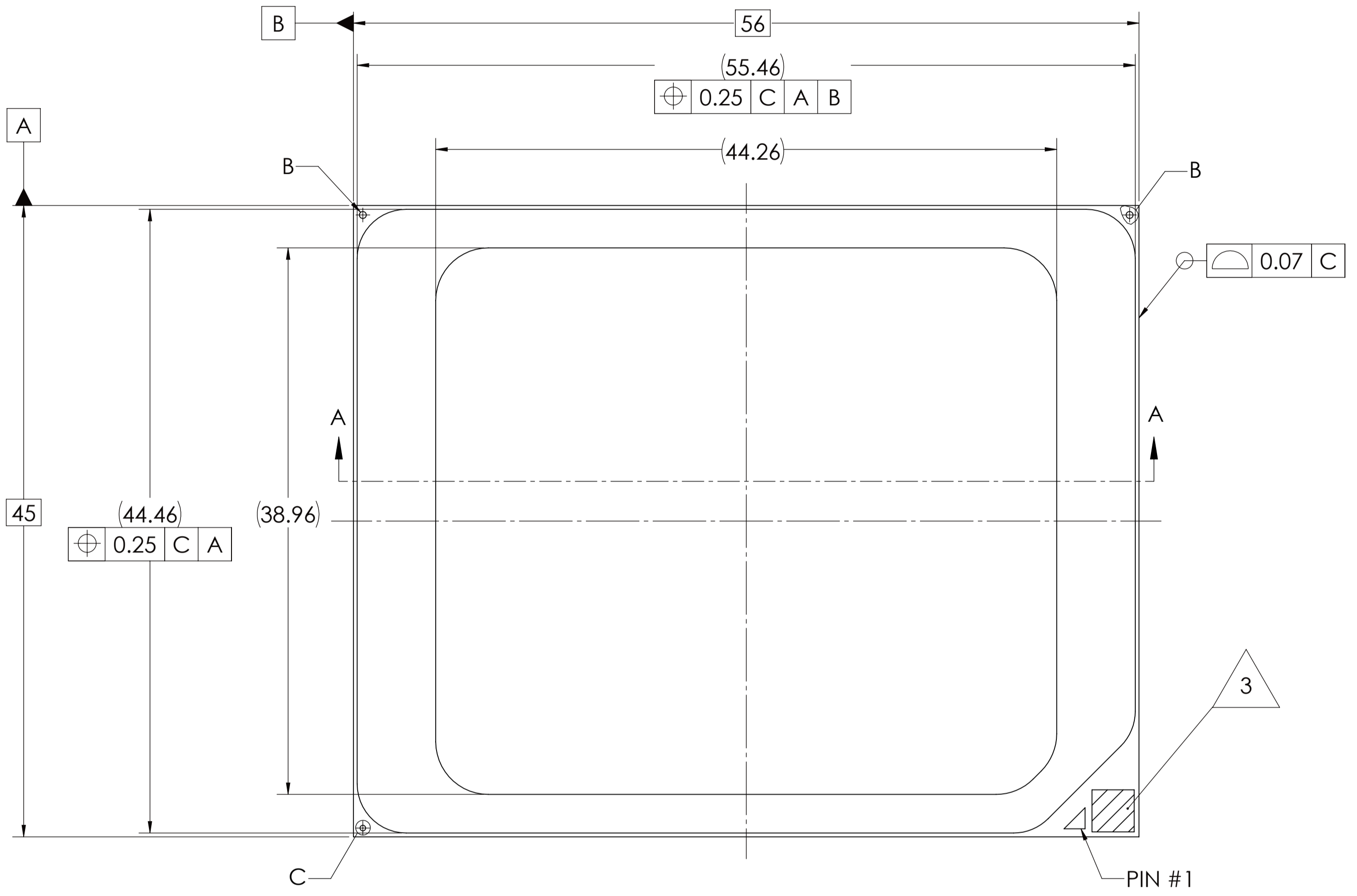
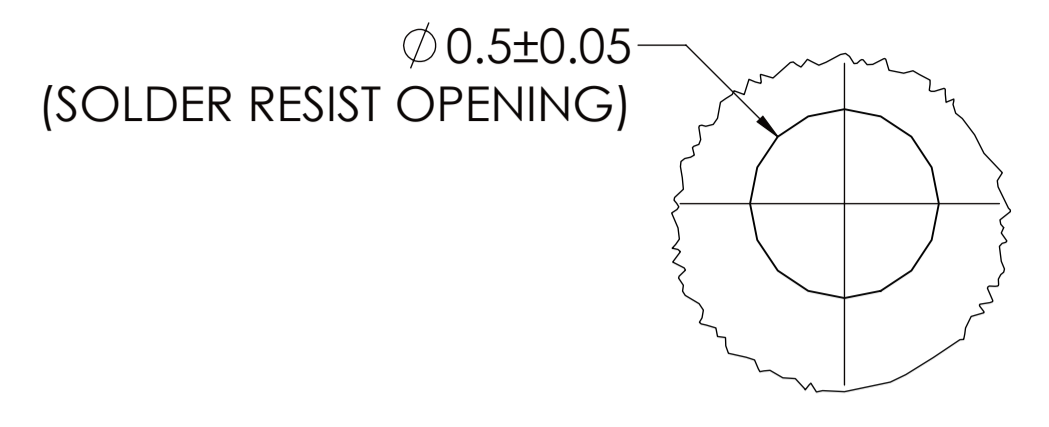
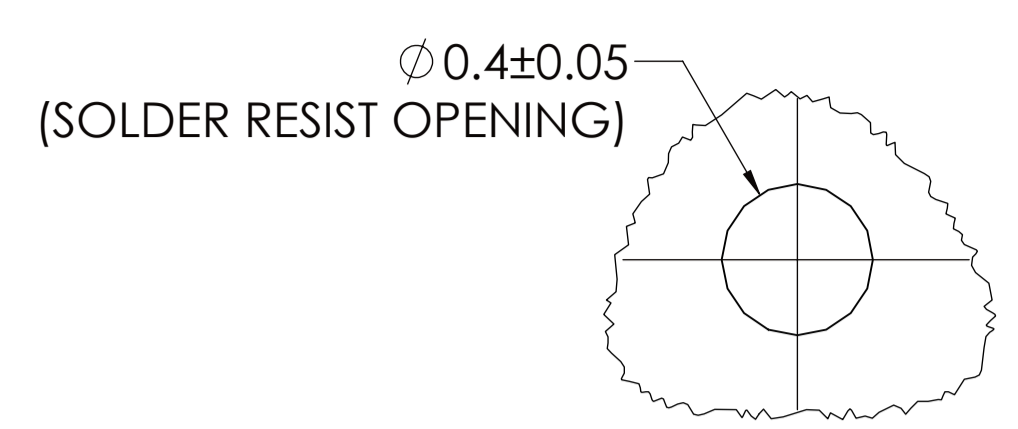

| | | | | |
|--|------------------------|------|--|--|
| UNLESS OTHERWISE SPECIFIED: DIMENSIONS ARE IN MILLIMETERS. INTERPRET DIMENSIONS AND TOLERANCES PER ASME Y14.5-2009. | DESIGNED BY | DATE | DEPARTMENT | 2200 MISSION COLLEGE BLVD. P.O. BOX 58119 SANTA CLARA, CA 95052-8119 |
| | DRAWN BY | DATE | TITLE | |
| | CHECKED BY | DATE | PACKAGE MECHANICAL DRAWING | |
| | APPROVED BY | DATE | 56mm X 45mm, 5-2-5 12 LAYER STACKUP, 3184 BGA | |
| MATERIAL: | THIRD ANGLE PROJECTION | | SIZE | DRAWING NUMBER |
| SEE NOTES | | | A1 | M97215 |
| | | | SCALE: 4:1 | DO NOT SCALE DRAWING |
| | | | SHEET 1 OF 2 | REV 03 |

8

7

6

5

4

3

1

H

H

G

G

F

F

E

E

D

D

C

C

B

B

A

A

| ZONE | REV | DESCRIPTION | DATE | APPR. |
|---------|-----|-------------------------------------|-----------|-------|
| - | 1 | ENGINEERING RELEASE | 9/18/2022 | KK |
| SH1 | 2 | REMOVED PRELIMINARY VALUE FLAG NOTE | 2/13/2023 | SM |
| SH1, D2 | 3 | ADDED BGA MIN PITCH TO BOTTOM VIEW | 5/14/2024 | SM |

8

7

6

5

4

3

2

1