

NOTES:

1. Project Drawing Numbers:

PB M88386-002
 PBA M88434-002
 MPN 100-0330708-B1
 TA M88453-002
 MMID 99C5L8

Note: The Parallel NOR flashes are updated from JTAG

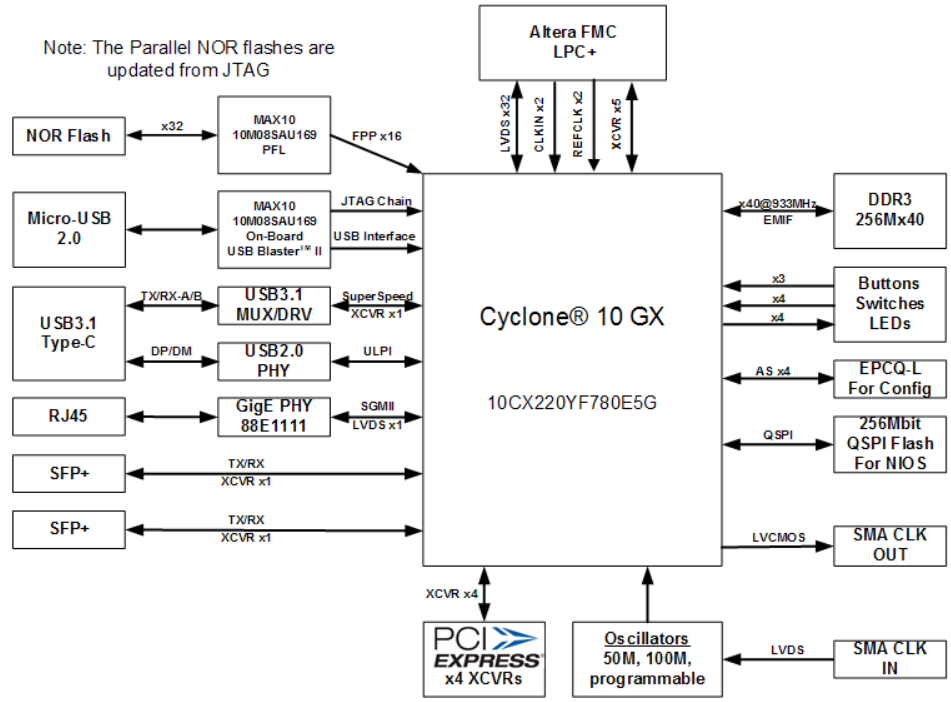

NOTE: THIS DESIGN IS LEVERAGED FROM OLD DESIGN i.e. MMID:979984

REV	DATE	PAGE	DESCRIPTION
A	09-09-2022	1 to 43	Initial Release
B	30-08-2023	1 to 43	Test point removed for SW and BST pins of VR's

PAGE	DESCRIPTION	PAGE	DESCRIPTION
1	01 - Title, Note, Block Diagram	24	24 - INTERFACE - USB3.1
2	02 - Clock Diagram	25	25 - INTERFACE - USB2.0
3	03 - Power Tree Diagram	26	26 - INTERFACE - GIGE - 1
4	04 - I2C JTAG Chain Diagram	27	27 - INTERFACE - GIGE - 2
5	05 - C10GX BANK CSS - Config	28	28 - SYS MAX10 - CTRL
6	06 - C10GX BANK1C/1D - XCVR	29	29 - SYS MAX10 - UBII
7	07 - C10GX BANK2K - EMIF	30	30 - CFG MAX10 - FPP
8	08 - C10GX BANK2J - EMIF	31	31 - CFG MAX10 - PFL
9	09 - C10GX BANK3A - FMC LVDS	32	32 - CFG PFL FLASH
10	10 - C10GX BANK3B - FMC LVDS	33	33 - LED & PB & SW
11	11 - C10GX BANK2A - FPP/GPIO	34	34 - POWER - INPUT
12	12 - C10GX BANK2L - GPIO	35	35 - POWER - 12V to 0.9V
13	13 - C10GX POWER	36	36 - POWER - 12V to 3.3V
14	14 - C10GX PWR Filter	37	37 - POWER - 12V to 5V
15	15 - C10GX GND	38	38 - POWER - 3.3V to 0.95V
16	16 - CLOCK - SI570/Si5332	39	39 - POWER - 3.3V to 1.5V
17	17 - CLOCK - SI5340	40	40 - POWER - 3.3V to 1.8V
18	18 - EMIF-DDR3-1	41	41 - POWER - 3.3V to VADJ
19	19 - EMIF-DDR3-2	42	42 - POWER - CURRENT SENSE
20	20 - INTERFACE - PCIe	43	43 - POWER - Fast Discharge
21	21 - INTERFACE - SFP+		
22	22 - INTERFACE - FMC - 1		
23	23 - INTERFACE - FMC - 2		



Altera Corporation, 101 Innovation Dr., San Jose CA 95134 © 2024 Altera Corporation. All Rights Reserved.		
Title CYCLONE 10 GX DEVKIT BOARD (NON-ENP)		
Size B	Document Number M88434-002 (100-0330708-B1)	Rev B
Date: Thursday, October 24, 2024	Sheet 1	of 43

Clock Diagram

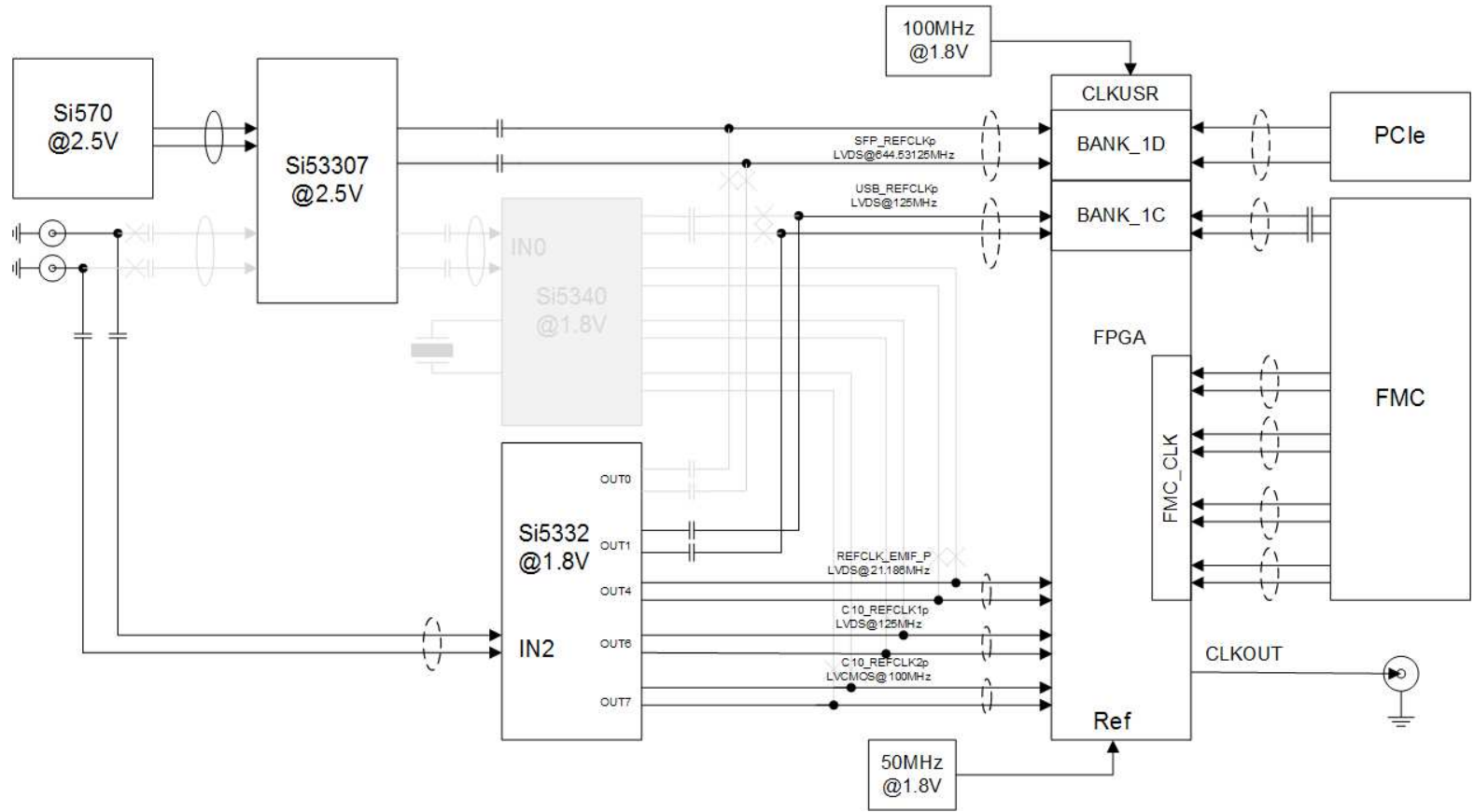

Altera Corporation, 101 Innovation Dr., San Jose CA 95134 © 2024 Altera Corporation. All Rights Reserved.		
Title CYCLONE 10 GX DEVKIT BOARD (NON-ENP)		
Size	Document Number	Rev
B	M88434-002 (100-0330708-B1)	B
Date:	Thursday, October 24, 2024	Sheet 2 of 49

Power Tree Diagram

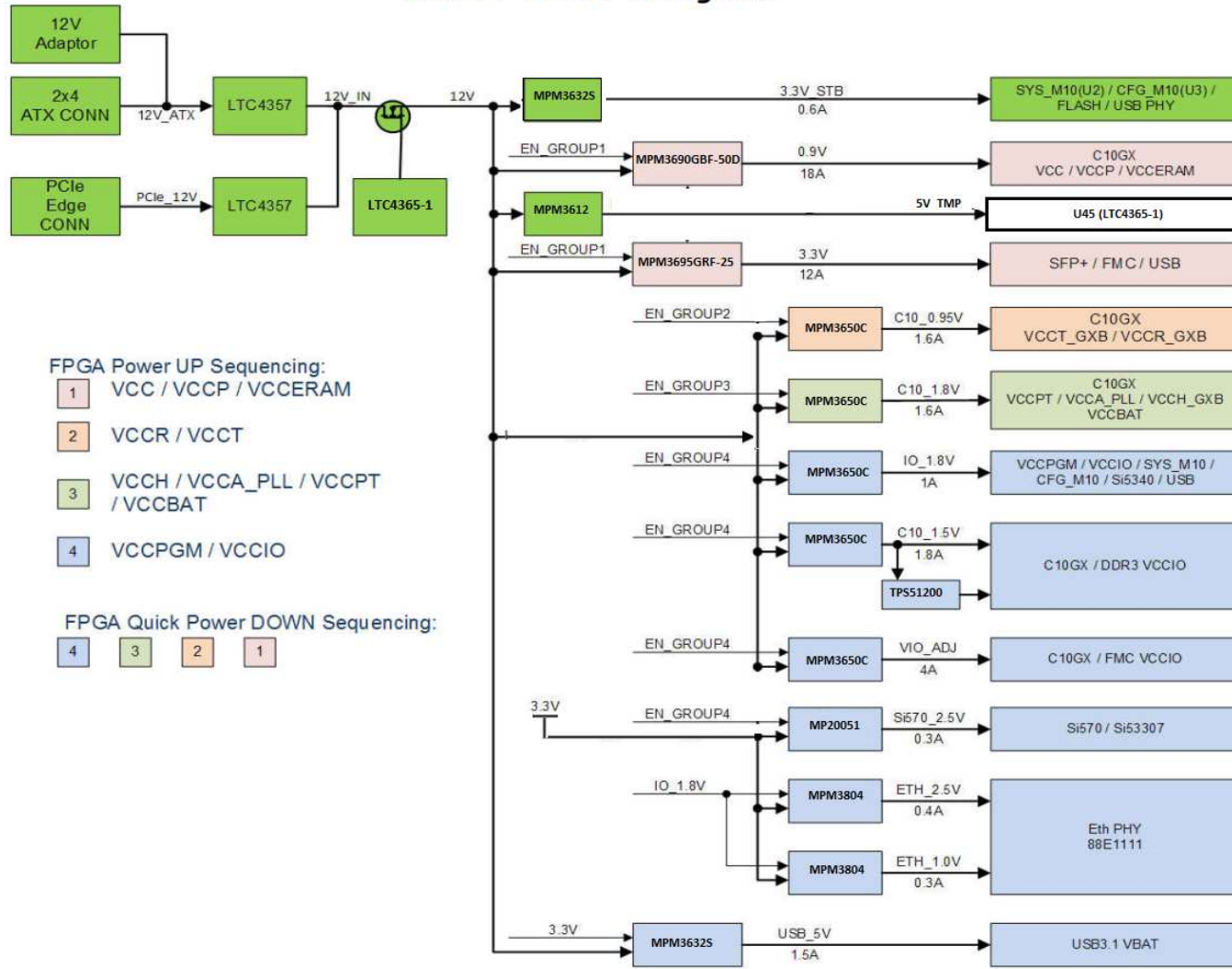

FPGA Power UP Sequencing:

- 1 VCC / VCCP / VCCERAM
- 2 VCCR / VCCT
- 3 VCCH / VCCA_PLL / VCCPT / VCCBAT
- 4 VCCPGM / VCCIO

FPGA Quick Power DOWN Sequencing:

- 4
- 3
- 2
- 1

I2C / JTAG Chain Diagram

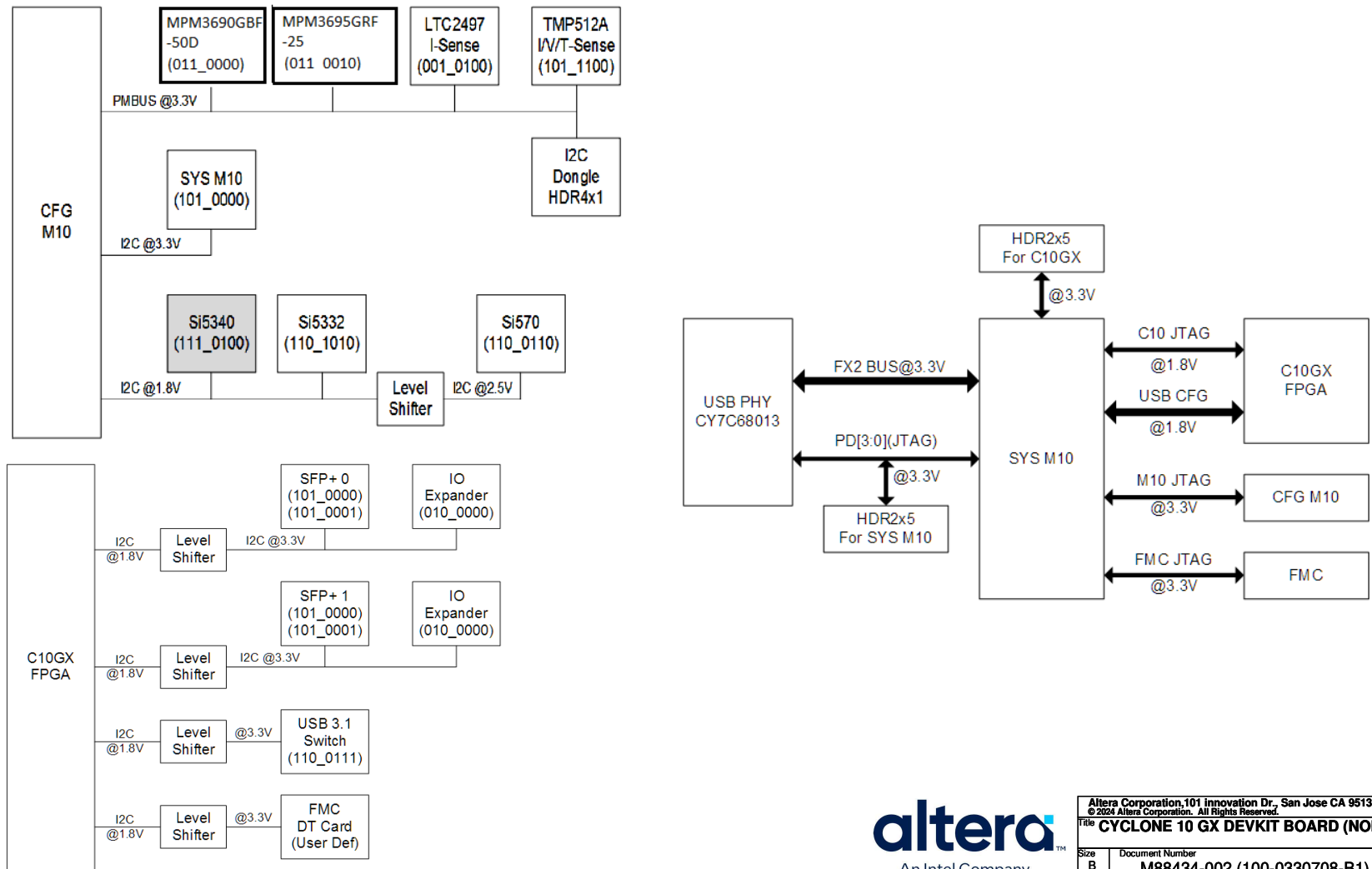

Altera Corporation, 101 Innovation Dr., San Jose CA 95134 © 2024 Altera Corporation. All Rights Reserved.		
Title CYCLONE 10 GX DEVKIT BOARD (NON-ENP)		
Size	Document Number	Rev
B	M88434-002 (100-0330708-B1)	B
Date:	Thursday, October 24, 2024	Sheet 4 of 49

C10GX BANK CSS - Config

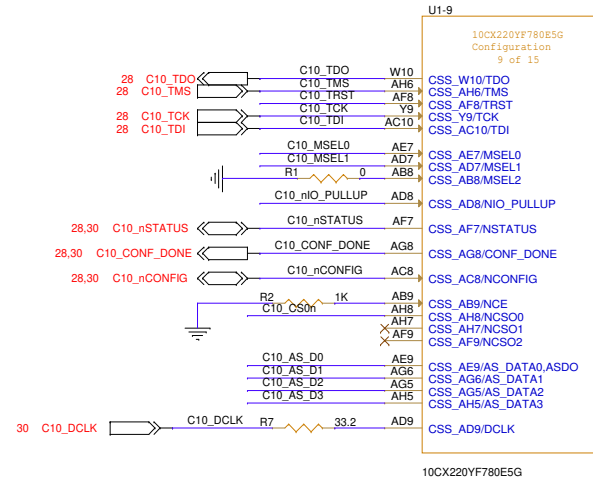
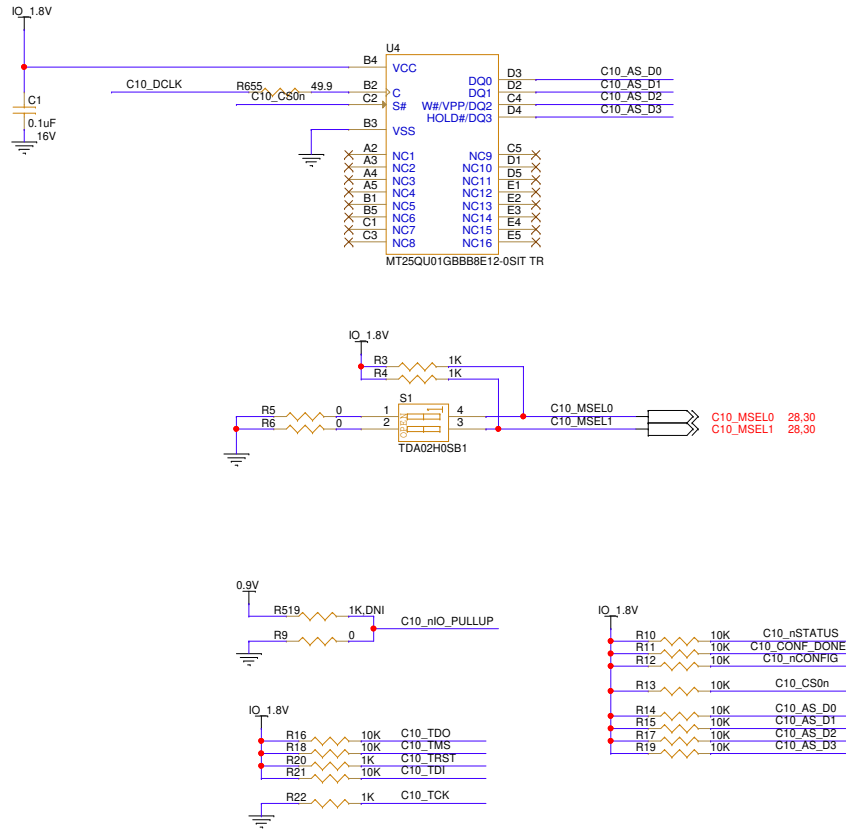

Configuration Scheme	V _{CCPGM} (V)	Power-On Reset (POR) Delay	Valid MSEL[2..0]
JTAG-based configuration	—	—	Use any valid MSEL pin settings below
AS (x1 and x4)	1.8	Fast	010
		Standard	011
PS and FPP (x8, x16, and x32)	1.2/1.5/1.8	Fast	000
		Standard	001

Note:
MSEL2 is fixed '0', MSEL1 and MSEL0 are '0' when corresponding switch is ON



Altera Corporation, 101 Innovation Dr., San Jose CA 95134 © 2024 Altera Corporation. All Rights Reserved.		
Title CYCLONE 10 GX DEVKIT BOARD (NON-ENP)		
Size	Document Number	Rev
B	M88434-002 (100-0330708-B1)	B
Date:	Thursday, October 24, 2024	Sheet 5 of 49

C10GX BANK1C/1D - XCVR

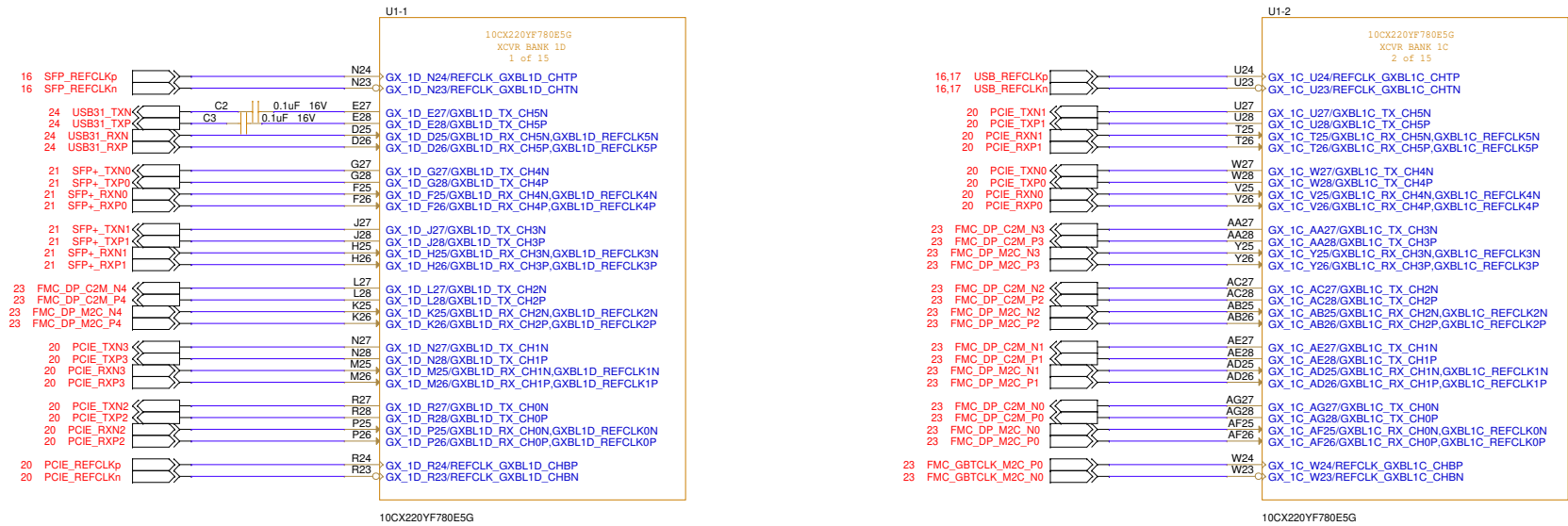

Altera Corporation, 101 Innovation Dr., San Jose CA 95134 © 2024 Altera Corporation. All Rights Reserved.		
Title CYCLONE 10 GX DEVKIT BOARD (NON-ENP)		
Size	Document Number	Rev
B	M88434-002 (100-0330708-B1)	B
Date:	Thursday, October 24, 2024	Sheet 6 of 49

C10GX BANK2J - EMIF

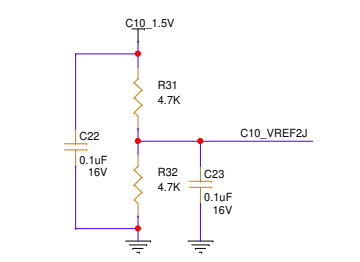
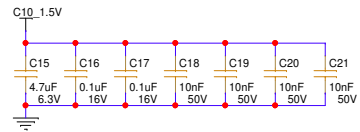
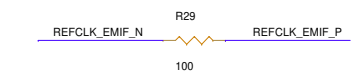
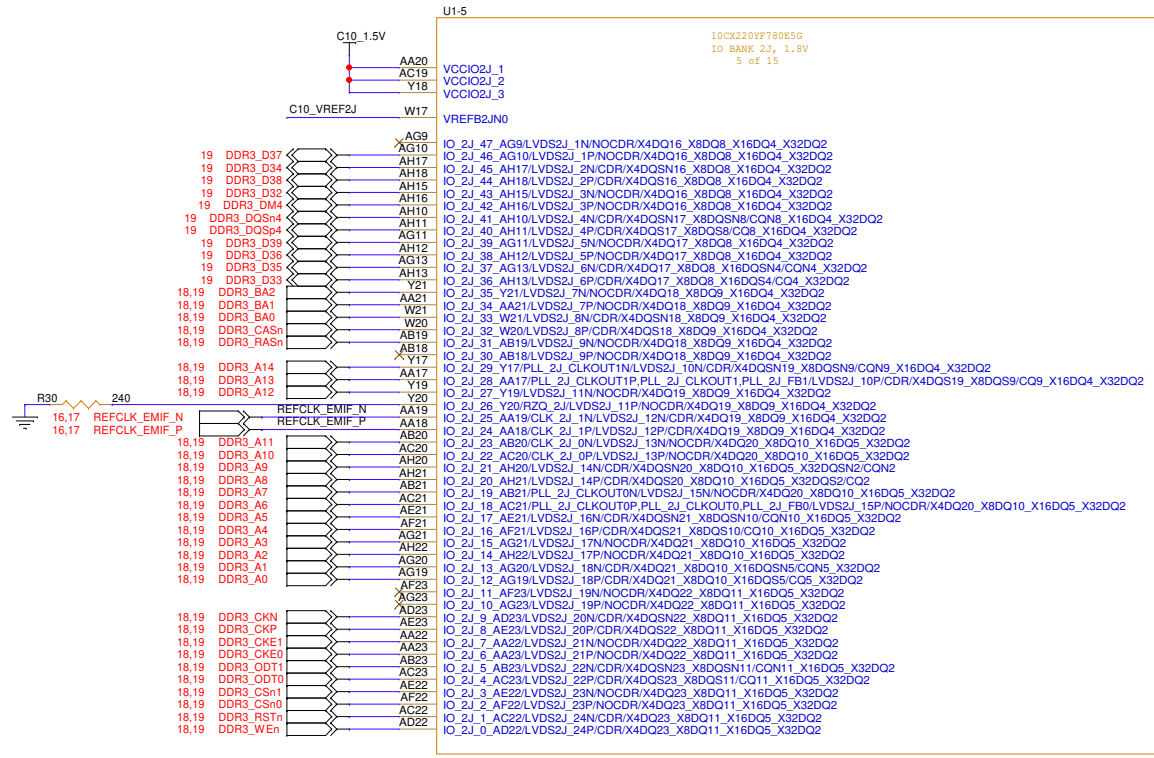

10CX220YF780E5G



Altera Corporation, 101 Innovation Dr., San Jose CA 95134		
© 2024 Altera Corporation. All Rights Reserved.		
Title CYCLONE 10 GX DEVKIT BOARD (NON-ENP)		
Size	Document Number	Rev
B	M88434-002 (100-0330708-B1)	B
Date:	Thursday, October 24, 2024	Sheet 8 of 49

C10GX BANK3A - FMC LVDS

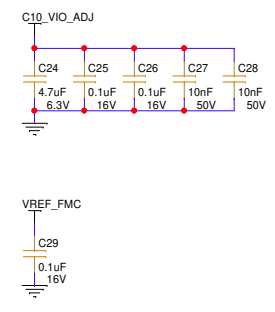
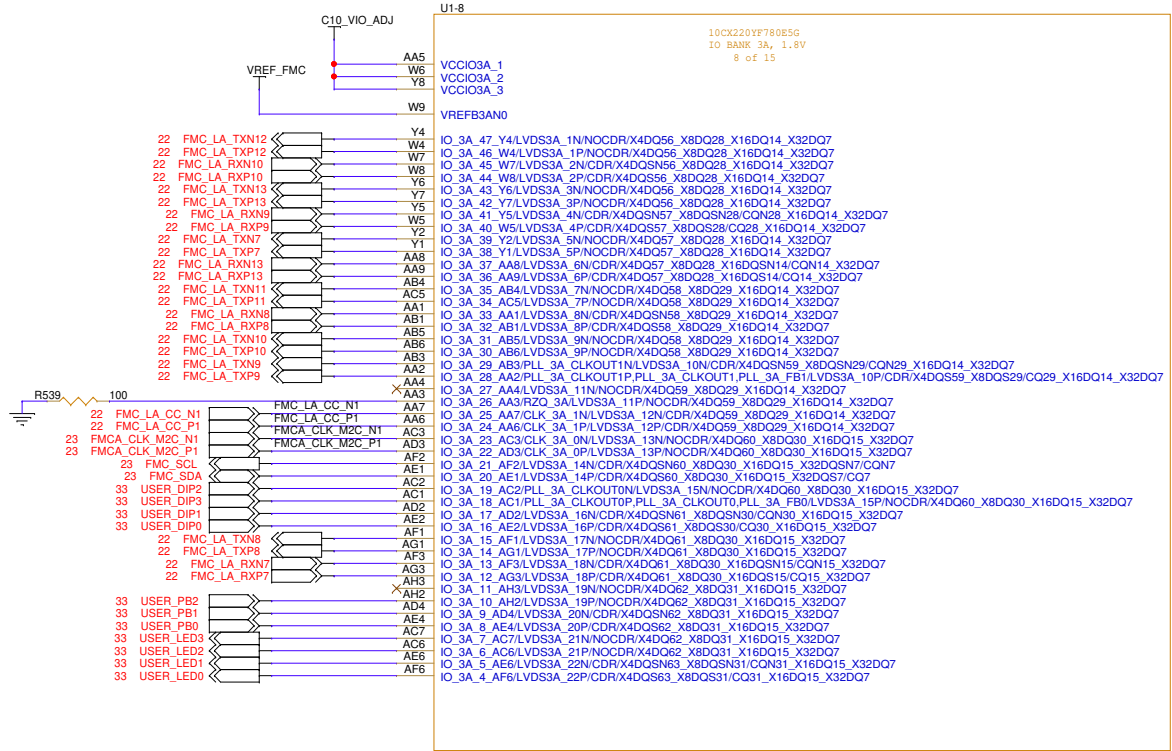

10CX220YF780ESG



Altera Corporation, 101 Innovation Dr., San Jose CA 95134 © 2024 Altera Corporation. All Rights Reserved.		
Title CYCLONE 10 GX DEVKIT BOARD (NON-ENP)		
Size B	Document Number M88434-002 (100-0330708-B1)	Rev B
Date: Thursday, October 24, 2024	Sheet 9	of 49

C10GX BANK3B - FMC LVDS

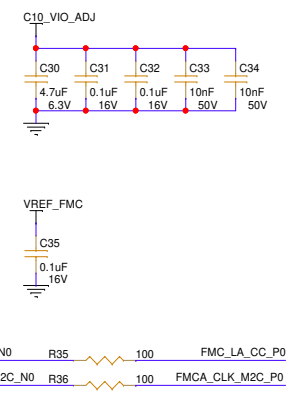
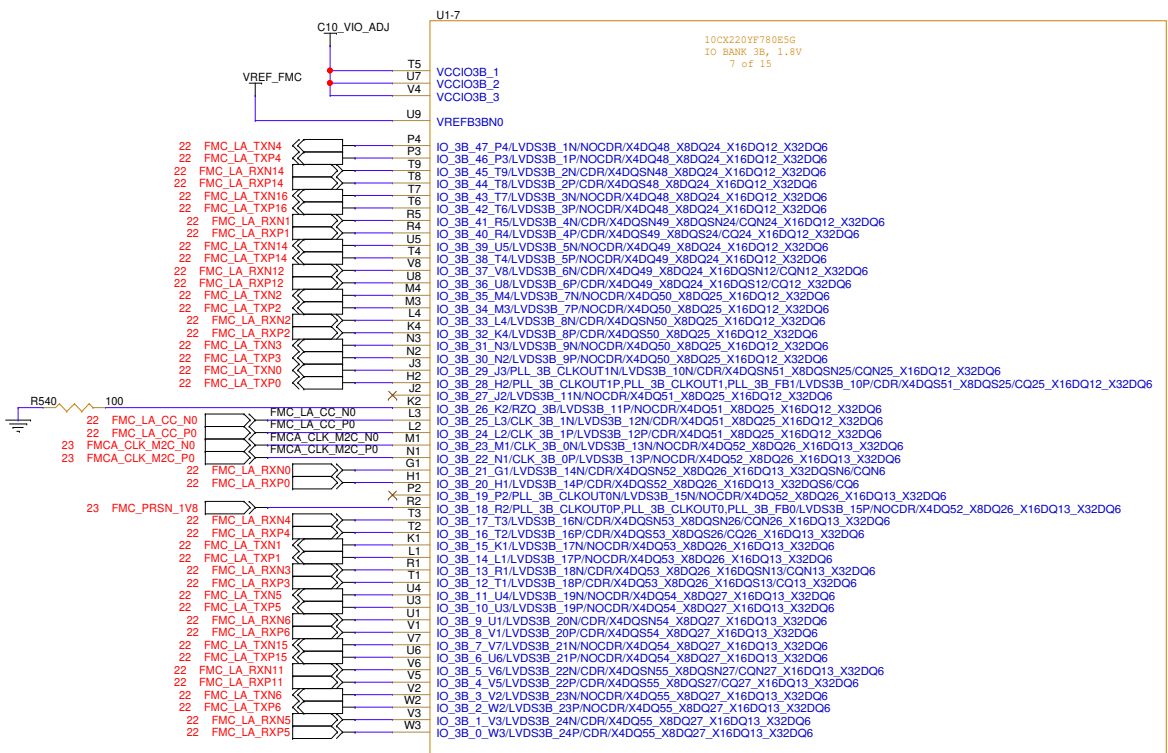

10CX220YF780E5G



Altera Corporation, 101 Innovation Dr., San Jose CA 95134 © 2024 Altera Corporation. All Rights Reserved.		
Title CYCLONE 10 GX DEVKIT BOARD (NON-ENP)		
Size	Document Number	Rev
B	M88434-002 (100-0330708-B1)	B
Date:	Thursday, October 24, 2024	Sheet 10 of 49

C10GX BANK2A - FPP/GPIO

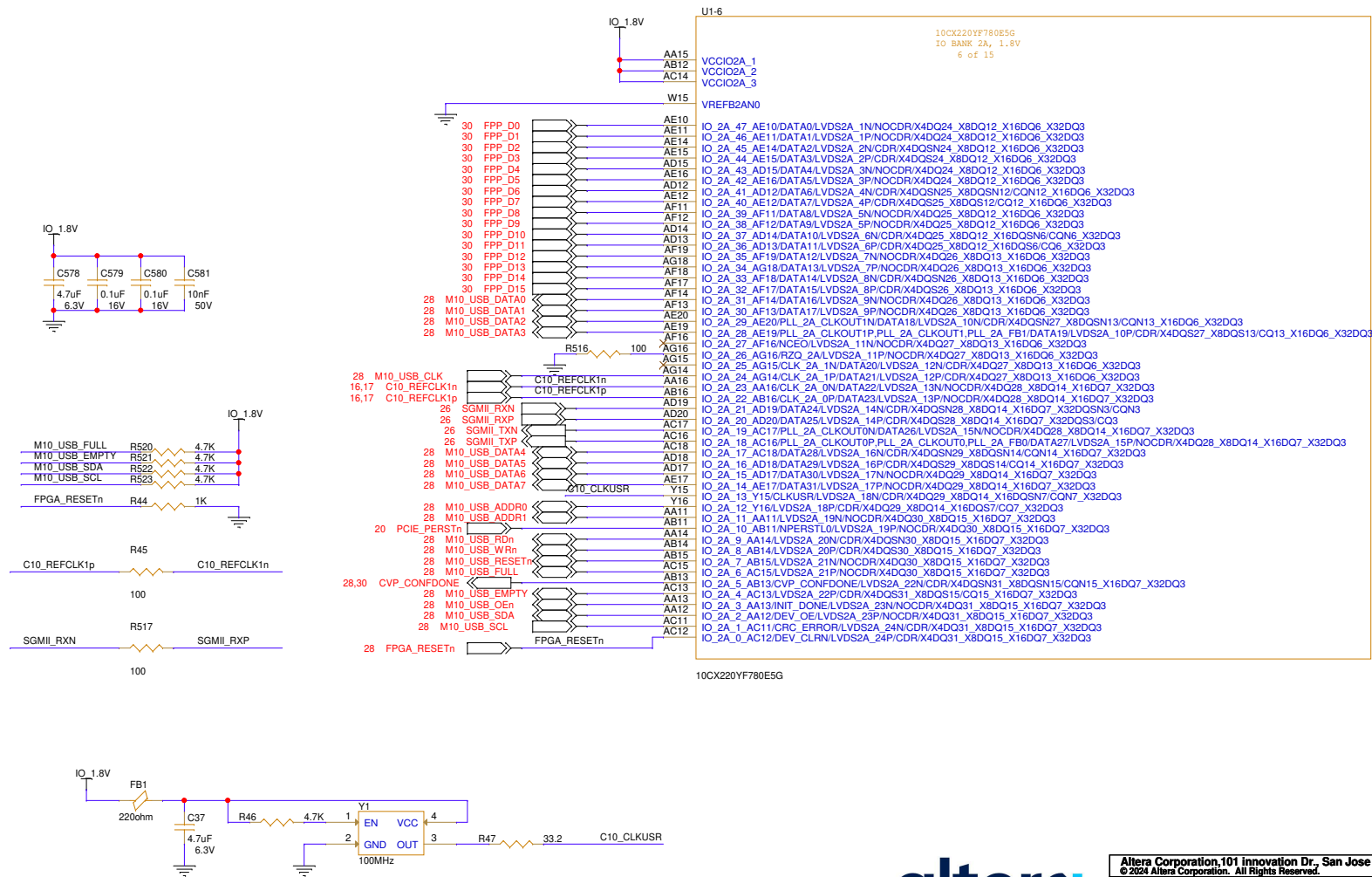

Altera Corporation, 101 Innovation Dr., San Jose CA 95134		
© 2024 Altera Corporation. All Rights Reserved.		
Title CYCLONE 10 GX DEVKIT BOARD (NON-ENP)		
Size	Document Number	Rev
B	M88434-002 (100-0330708-B1)	B
Date:	Thursday, October 24, 2024	Sheet 11 of 49

C10GX BANK2L - GPIO

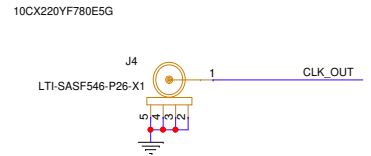
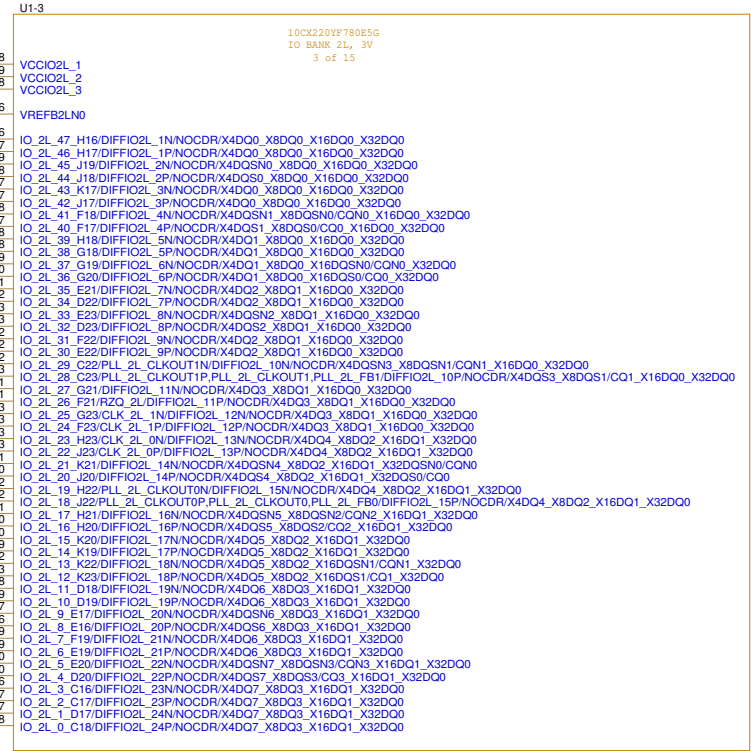
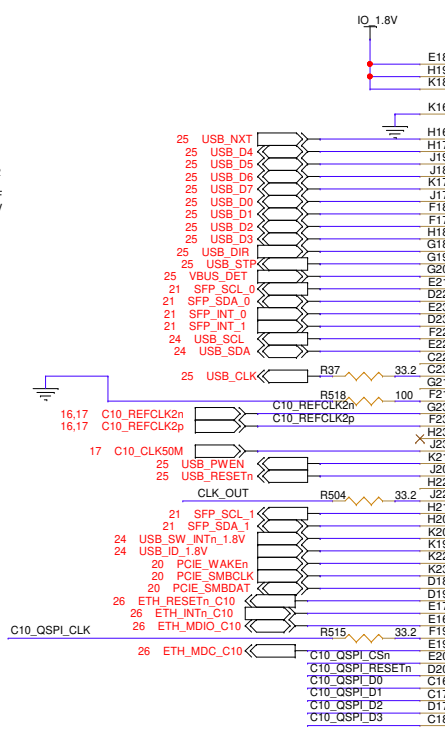
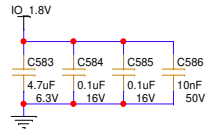
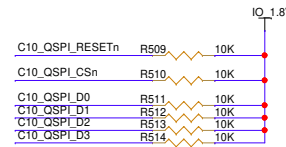
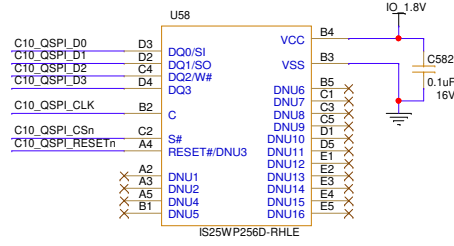

Altera Corporation, 101 Innovation Dr., San Jose CA 95134		
© 2024 Altera Corporation. All Rights Reserved.		
Title CYCLONE 10 GX DEVKIT BOARD (NON-ENP)		
Size	Document Number	Rev
B	M88434-002 (100-0330708-B1)	B
Date:	Thursday, October 24, 2024	Sheet 12 of 49

C10GX POWER

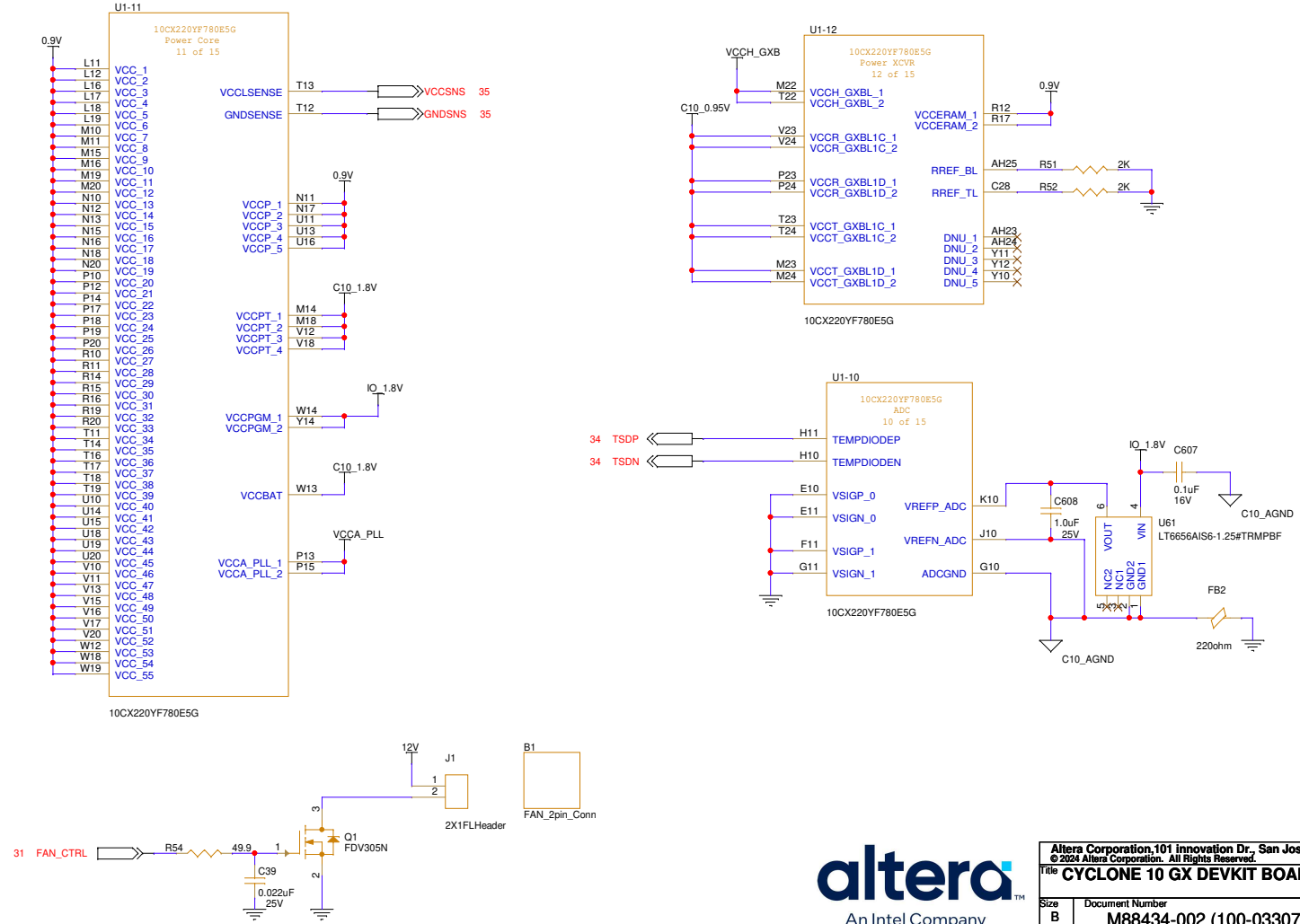

Altera Corporation, 101 Innovation Dr., San Jose CA 95134		
© 2024 Altera Corporation. All Rights Reserved.		
Title CYCLONE 10 GX DEVKIT BOARD (NON-ENP)		
Size	Document Number	Rev
B	M88434-002 (100-0330708-B1)	B
Date:	Thursday, October 24, 2024	Sheet 13 of 49

C10GX PWR Filter

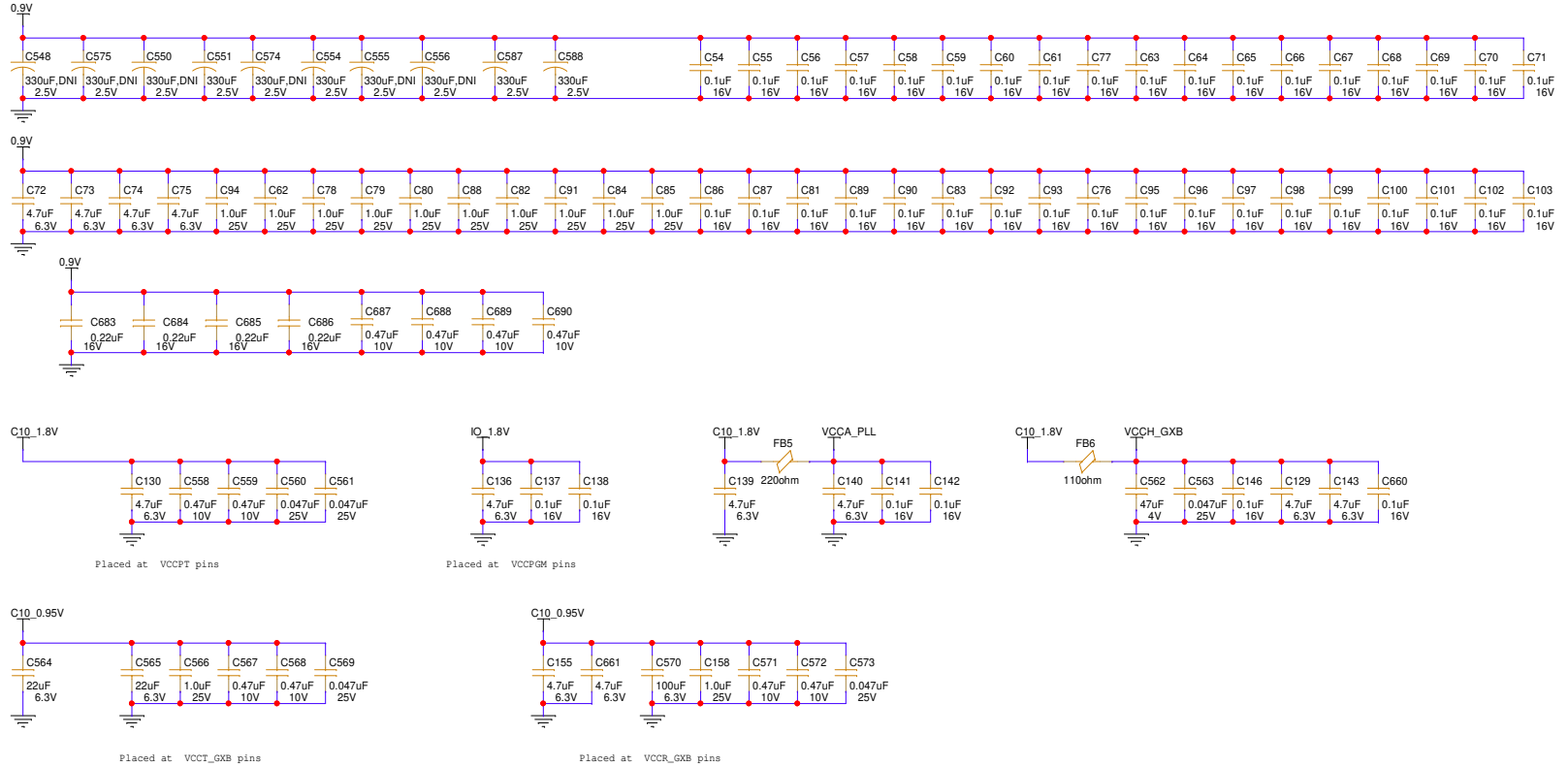

Altera Corporation, 101 Innovation Dr., San Jose CA 95134		
© 2024 Altera Corporation. All Rights Reserved.		
Title CYCLONE 10 GX DEVKIT BOARD (NON-ENP)		
Size	Document Number	Rev
B	M88434-002 (100-0330708-B1)	B
Date:	Thursday, October 24, 2024	Sheet 14 of 49

C10GX GND

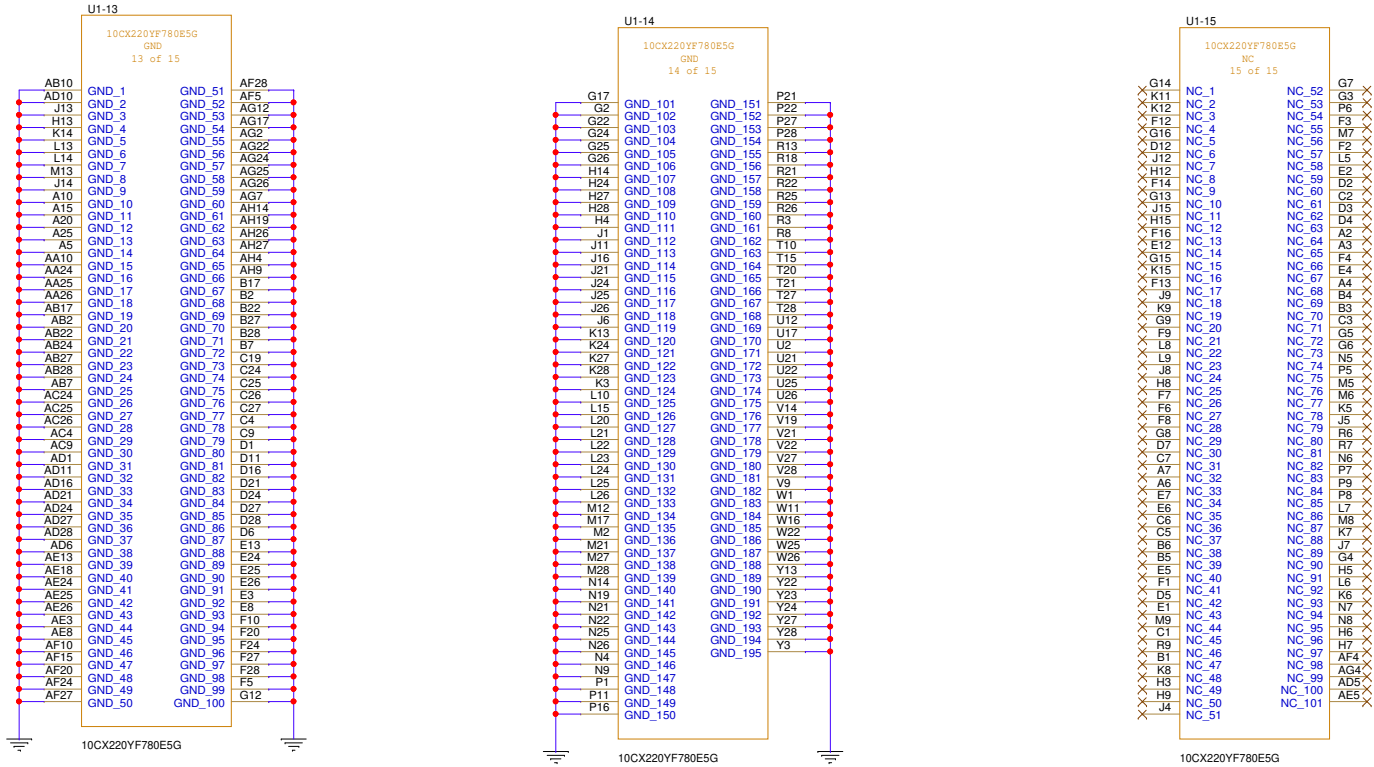

Altera Corporation, 101 Innovation Dr., San Jose CA 95134		
© 2024 Altera Corporation. All Rights Reserved.		
Title CYCLONE 10 GX DEVKIT BOARD (NON-ENP)		
Size	Document Number	Rev
B	M88434-002 (100-0330708-B1)	B
Date:	Thursday, October 24, 2024	Sheet 15 of 49

CLOCK - SI5340

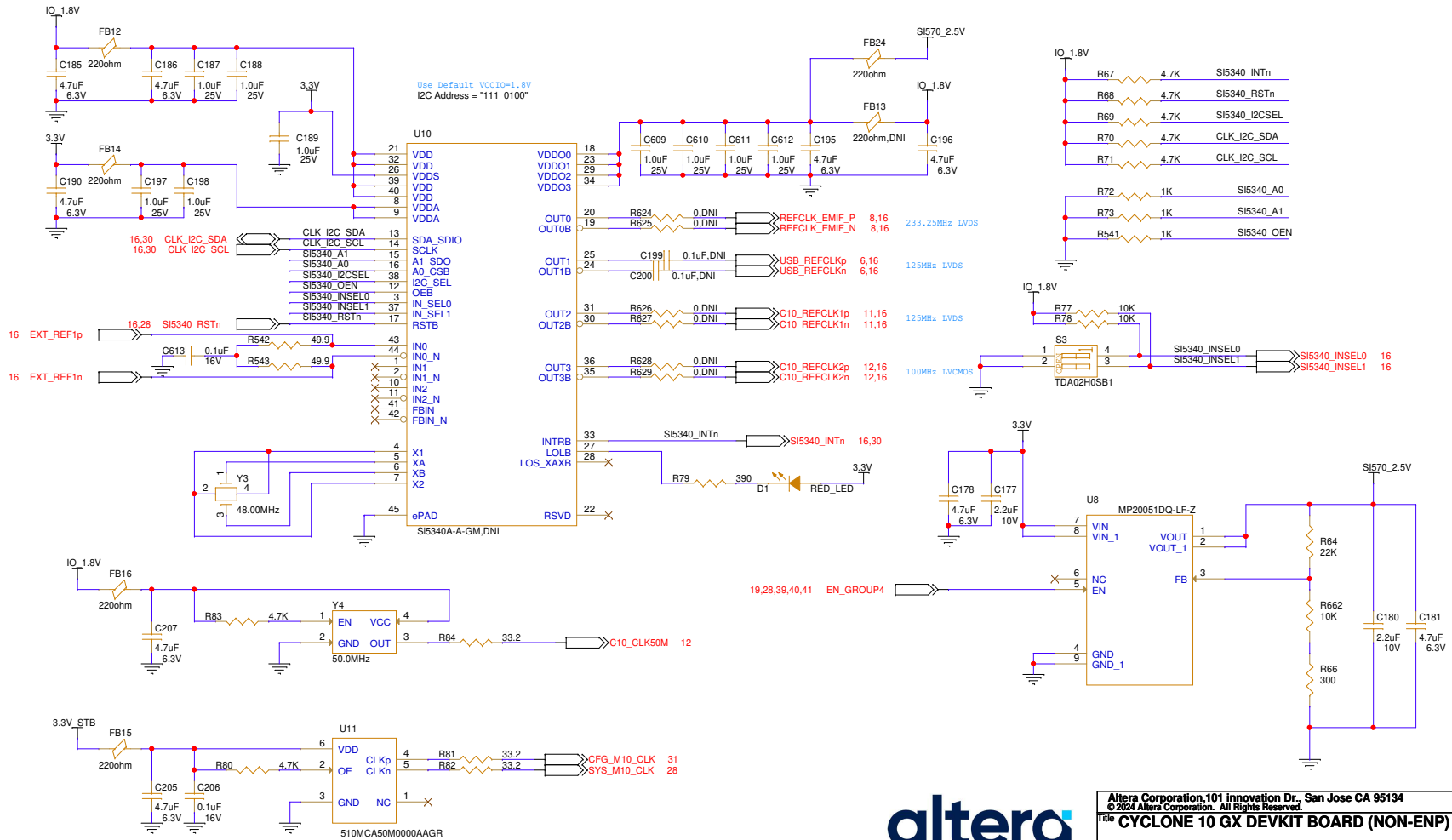

Altera Corporation, 101 Innovation Dr., San Jose CA 95134		
© 2024 Altera Corporation. All Rights Reserved.		
Title CYCLONE 10 GX DEVKIT BOARD (NON-ENP)		
Size	Document Number	Rev
B	M88434-002 (100-0330708-B1)	B
Date:	Thursday, October 24, 2024	Sheet 17 of 49

EMIF-DDR3-1

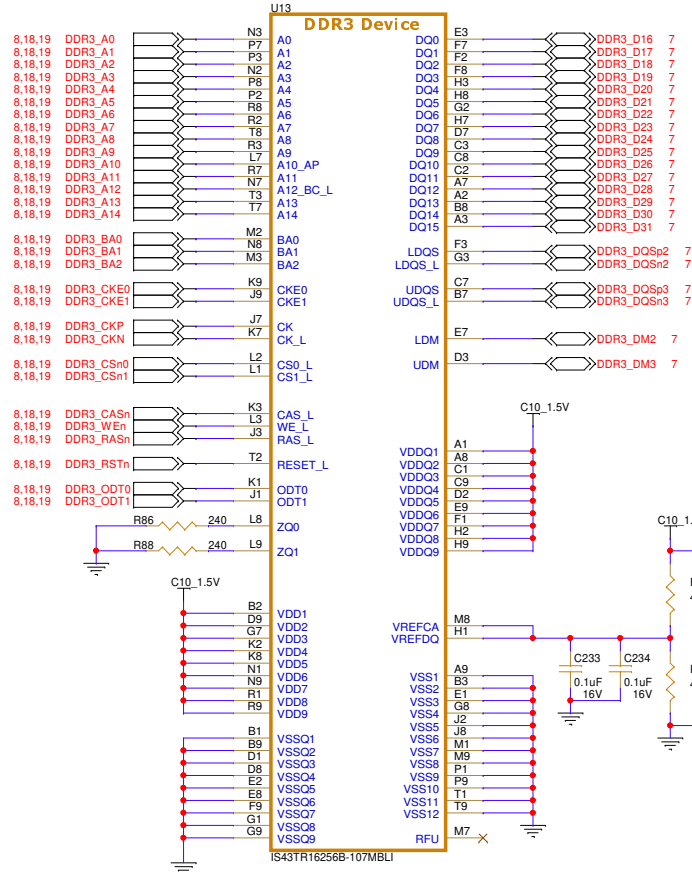
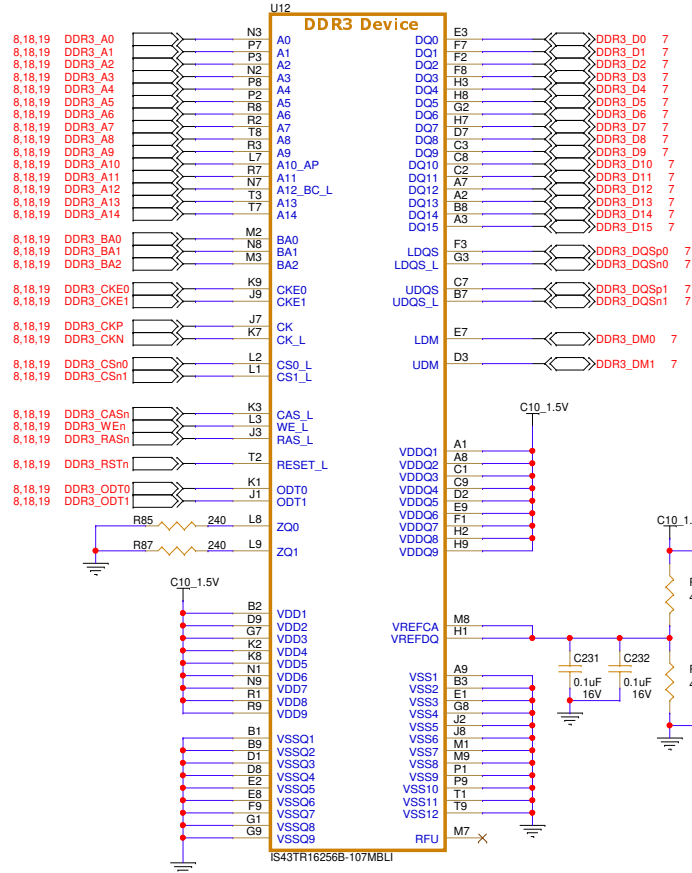
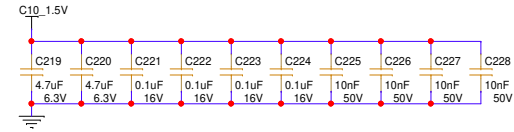
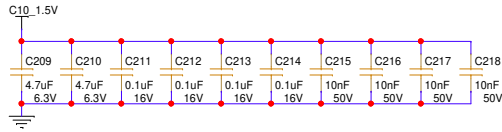

Altera Corporation, 101 Innovation Dr., San Jose CA 95134 © 2024 Altera Corporation. All Rights Reserved.		
Title CYCLONE 10 GX DEVKIT BOARD (NON-ENP)		
Size	Document Number	Rev
B	M88434-002 (100-0330708-B1)	B
Date:	Thursday, October 24, 2024	Sheet 18 of 49

INTERFACE - PCIe

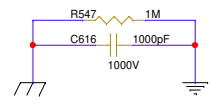
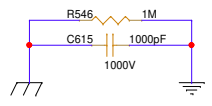
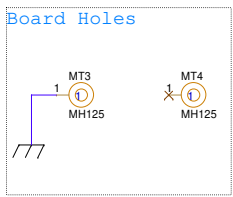
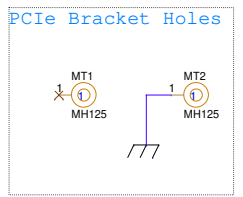
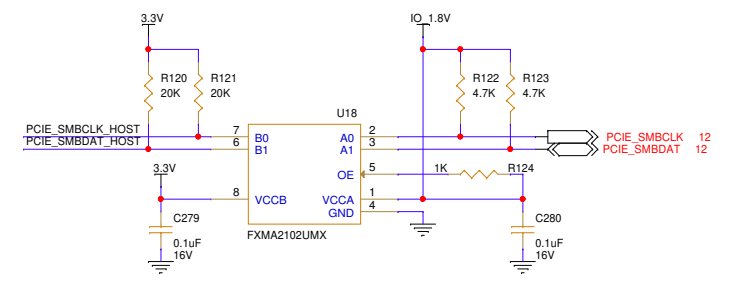
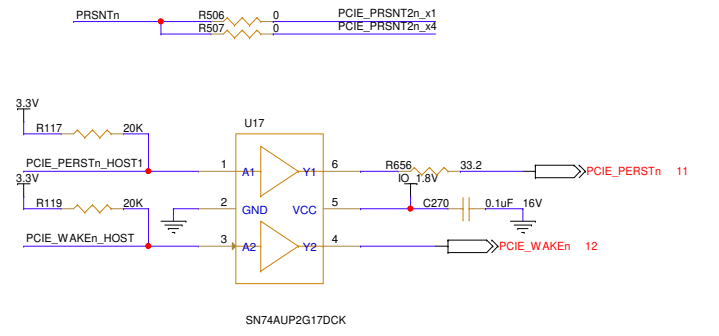
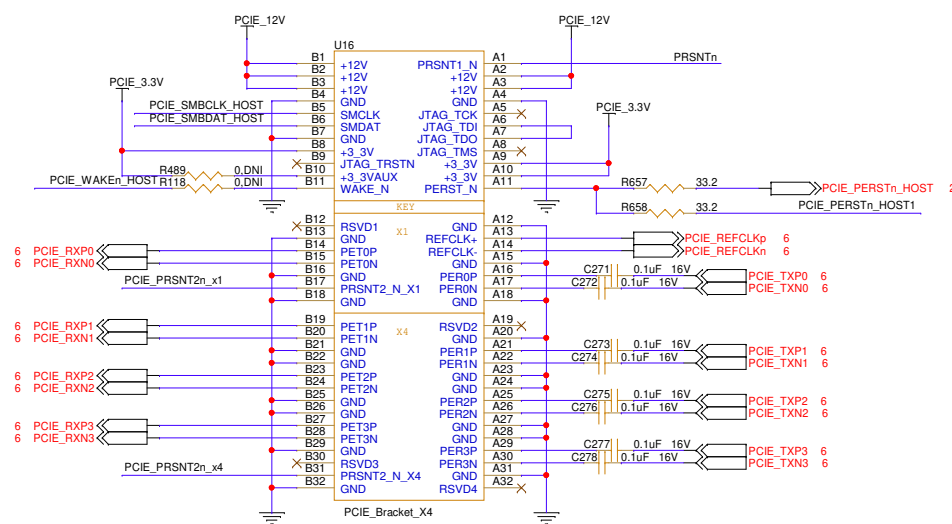

Altera Corporation, 101 Innovation Dr., San Jose CA 95134		
© 2024 Altera Corporation. All Rights Reserved.		
Title CYCLONE 10 GX DEVKIT BOARD (NON-ENP)		
Size	Document Number	Rev
B	M88434-002 (100-0330708-B1)	B
Date:	Thursday, October 24, 2024	Sheet 20 of 49

INTERFACE - SFP+

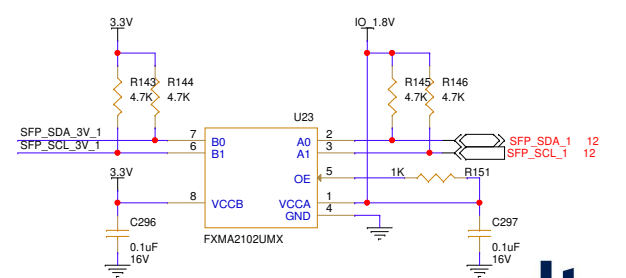
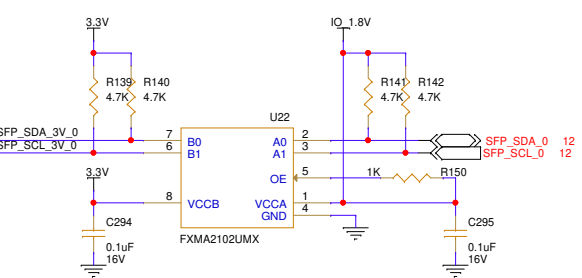
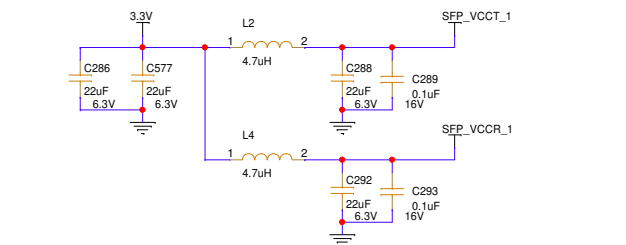
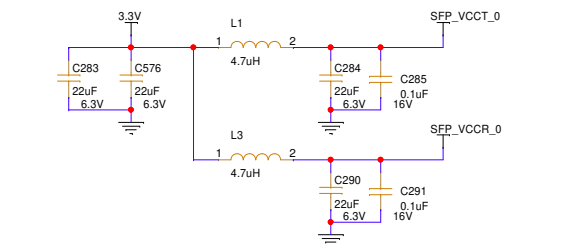
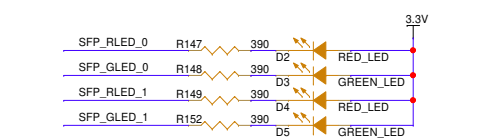
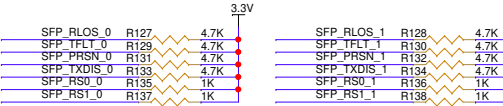
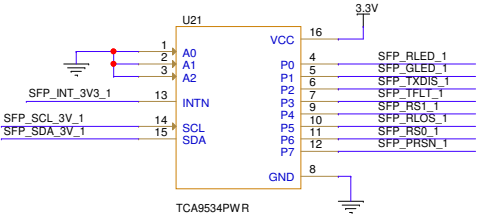
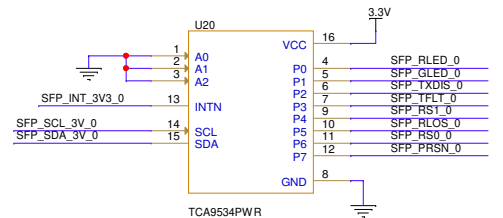
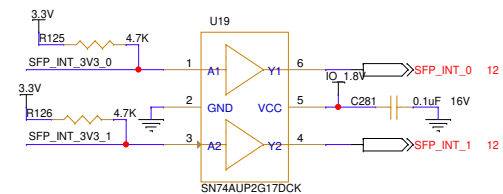
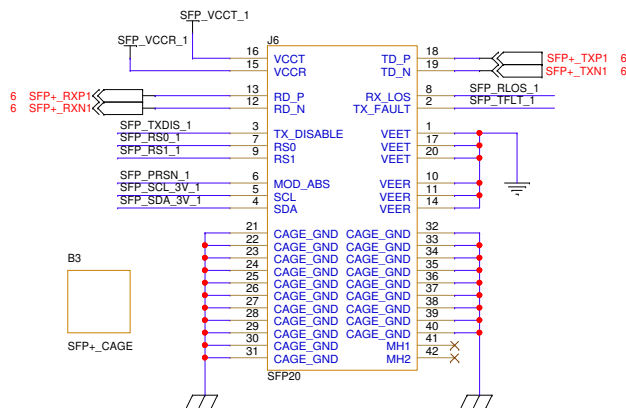
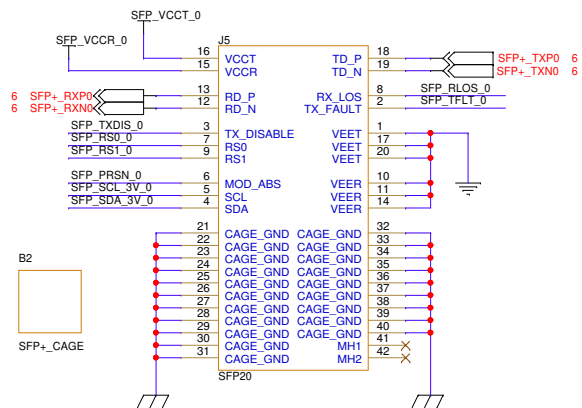

Altera Corporation, 101 Innovation Dr., San Jose CA 95134		
© 2024 Altera Corporation. All Rights Reserved.		
Title CYCLONE 10 GX DEVIK BOARD (NON-ENP)		
Size	Document Number	Rev
B	M88434-002 (100-0330708-B1)	B
Date:	Thursday, October 24, 2024	Sheet 21 of 49

INTERFACE - FMC - 1

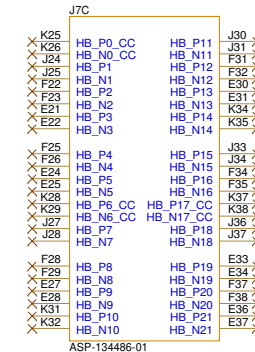
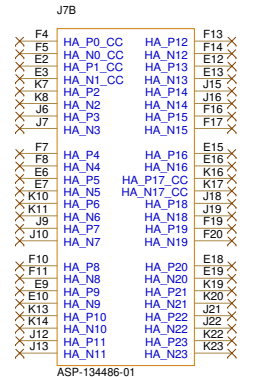
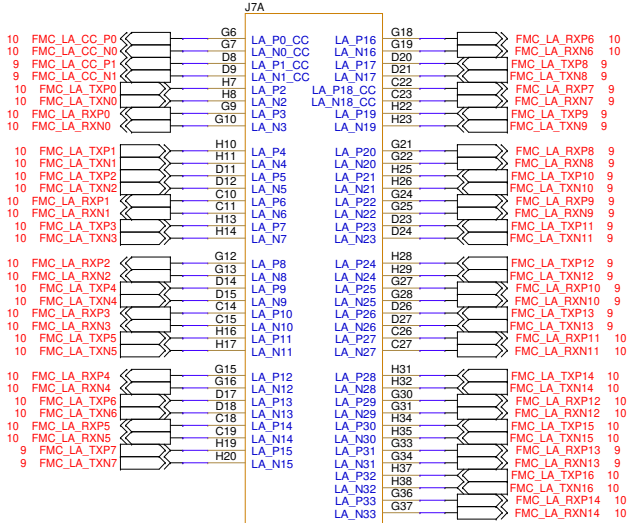
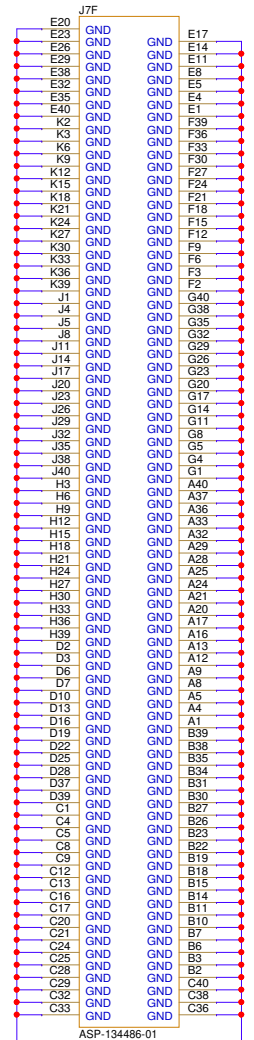

FMC cards Supported:
 12G SDI: Semtech RDK-12GSRD-ALTRA00 Evaluation Board
 8G Displayport: Bitec FMC DisplayPort Daughter Card
 6G HDMI 2.0: Bitec FMC HDMI Daughter Card



Altera Corporation, 101 Innovation Dr., San Jose CA 95134 © 2024 Altera Corporation. All Rights Reserved.		
Title CYCLONE 10 GX DEVKIT BOARD (NON-ENP)		
Size	Document Number	Rev
B	M88434-002 (100-0330708-B1)	B
Date:	Thursday, October 24, 2024	Sheet 22 of 43

INTERFACE - FMC - 2

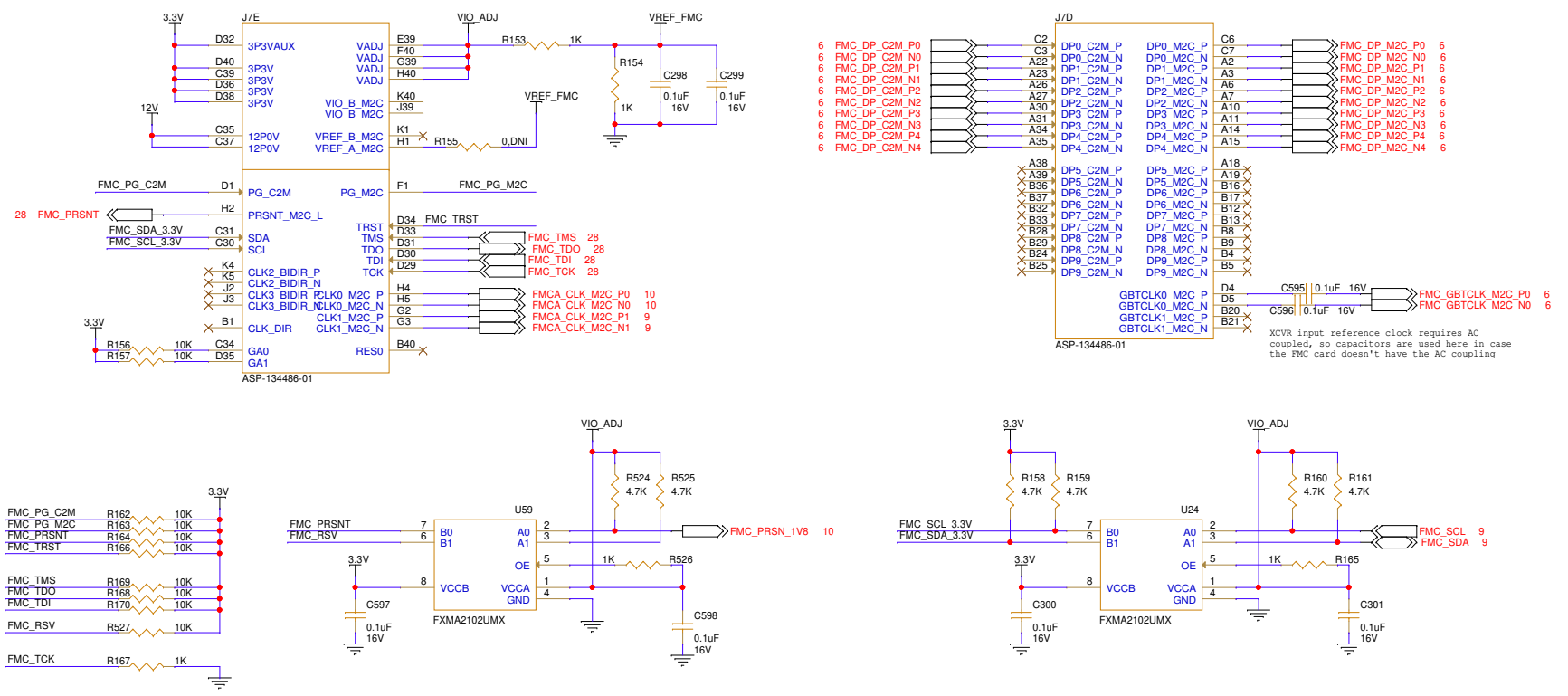

Altera Corporation, 101 Innovation Dr., San Jose CA 95134 © 2024 Altera Corporation. All Rights Reserved.		
Title CYCLONE 10 GX DEVKIT BOARD (NON-ENP)		
Size	Document Number	Rev
B	M88434-002 (100-0330708-B1)	B
Date:	Thursday, October 24, 2024	Sheet 23 of 49

INTERFACE - USB3.1

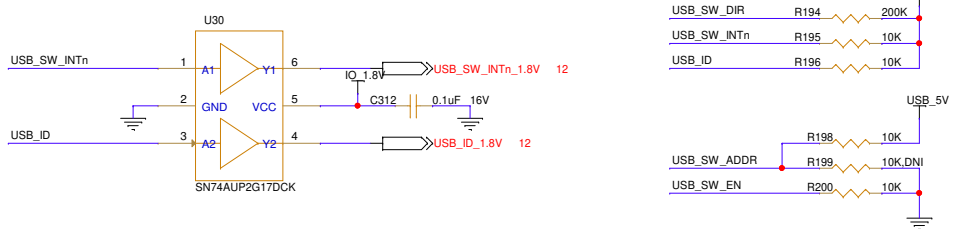
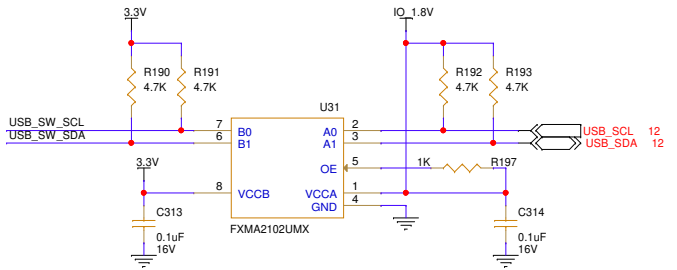
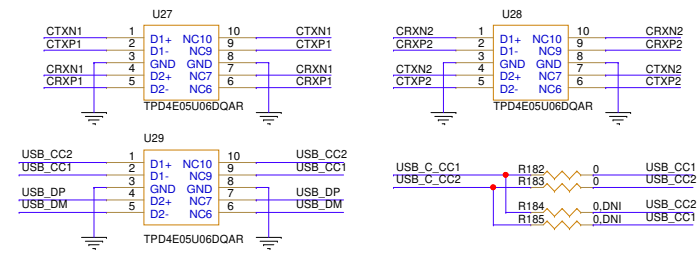
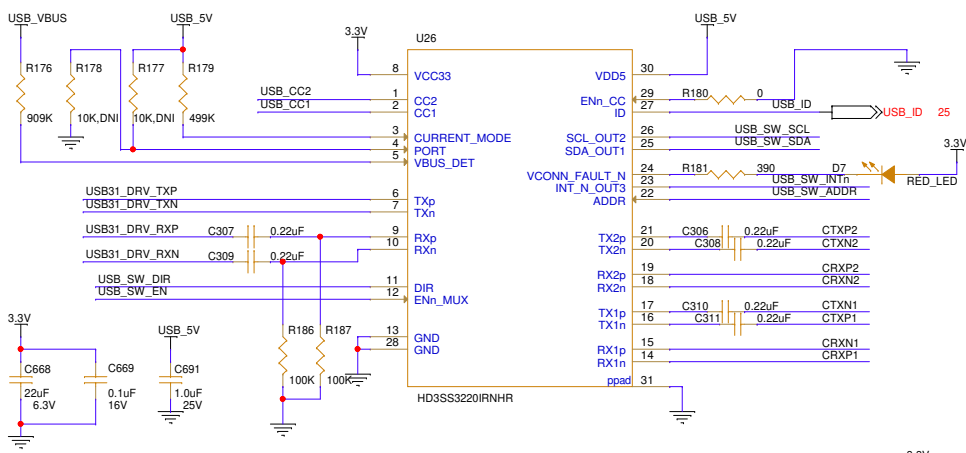
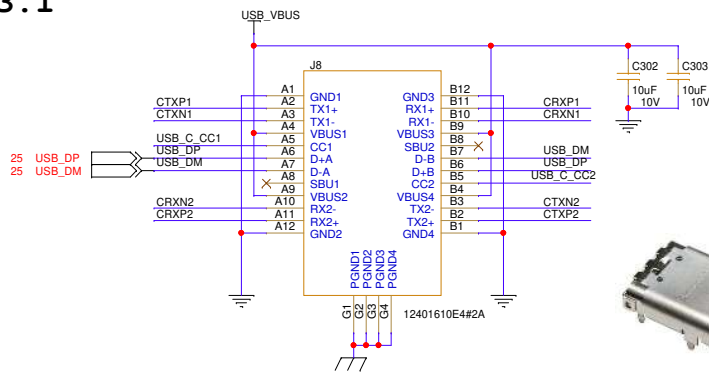
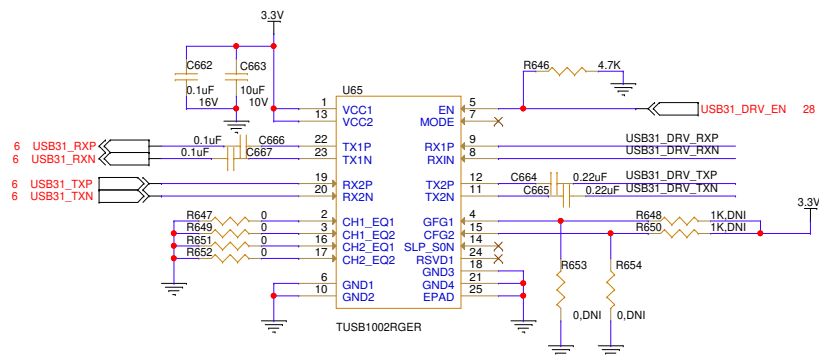

Altera Corporation, 101 Innovation Dr., San Jose CA 95134		
© 2024 Altera Corporation. All Rights Reserved.		
Title CYCLONE 10 GX DEVKIT BOARD (NON-ENP)		
Size	Document Number	Rev
B	M88434-002 (100-0330708-B1)	B
Date:	Thursday, October 24, 2024	Sheet 24 of 49

INTERFACE - USB2.0

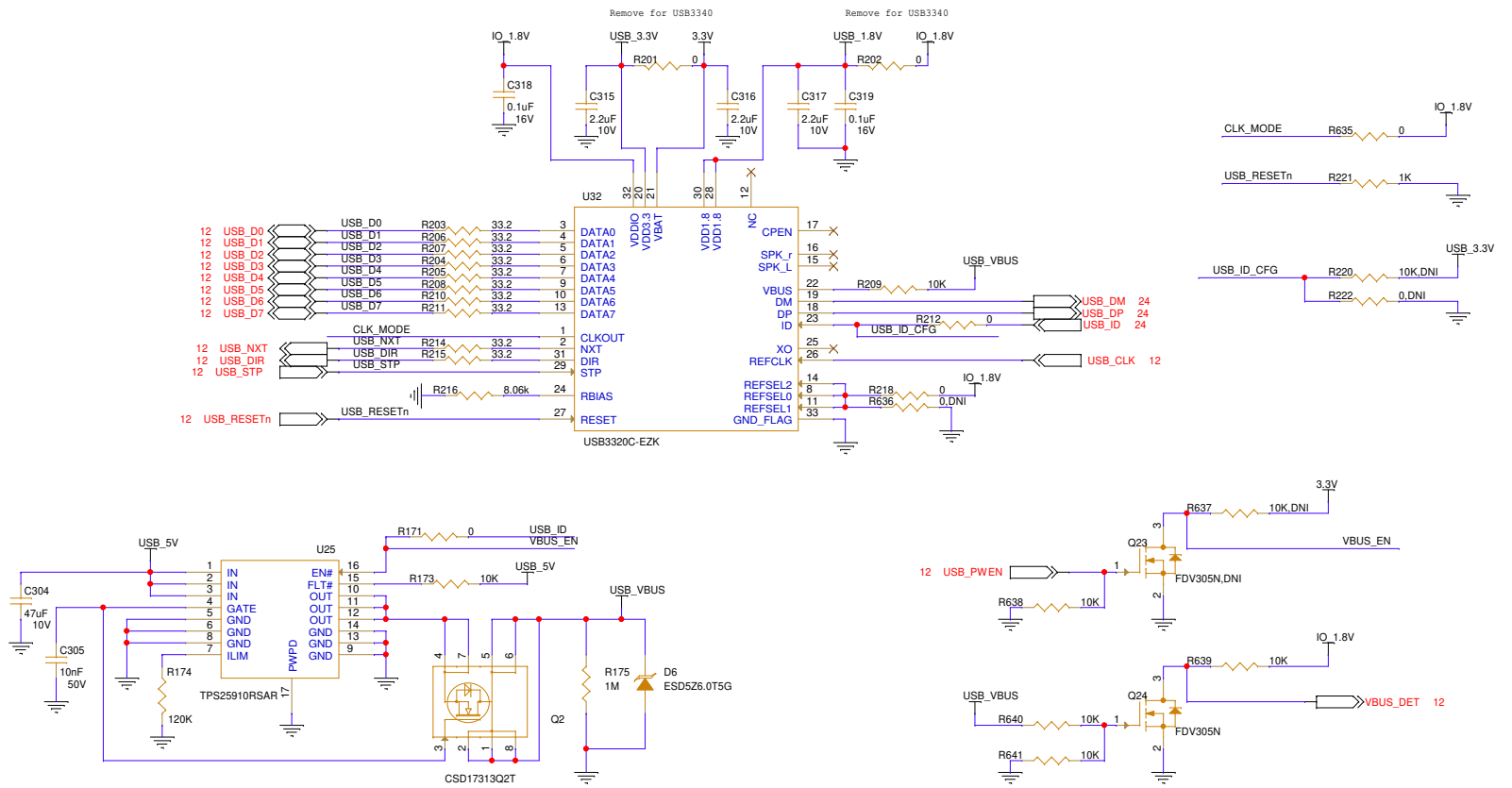

Altera Corporation, 101 Innovation Dr., San Jose CA 95134		
© 2024 Altera Corporation. All Rights Reserved.		
Title CYCLONE 10 GX DEVKIT BOARD (NON-ENP)		
Size	Document Number	Rev
B	M88434-002 (100-0330708-B1)	B
Date:	Thursday, October 24, 2024	Sheet 25 of 49

INTERFACE - GIGE - 1

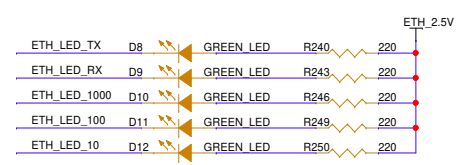
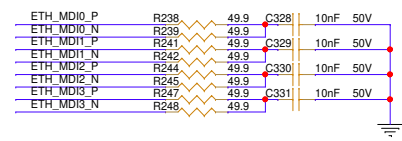
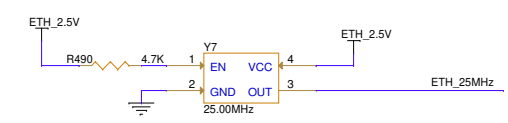
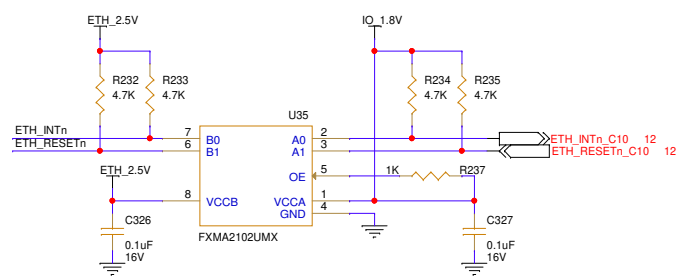
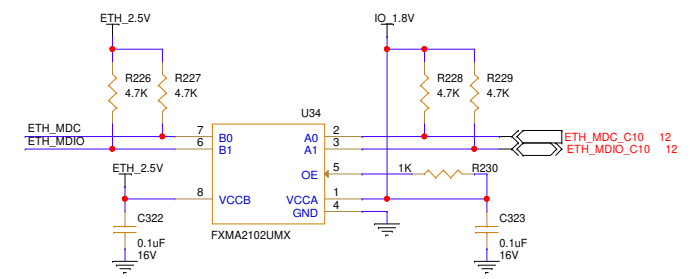
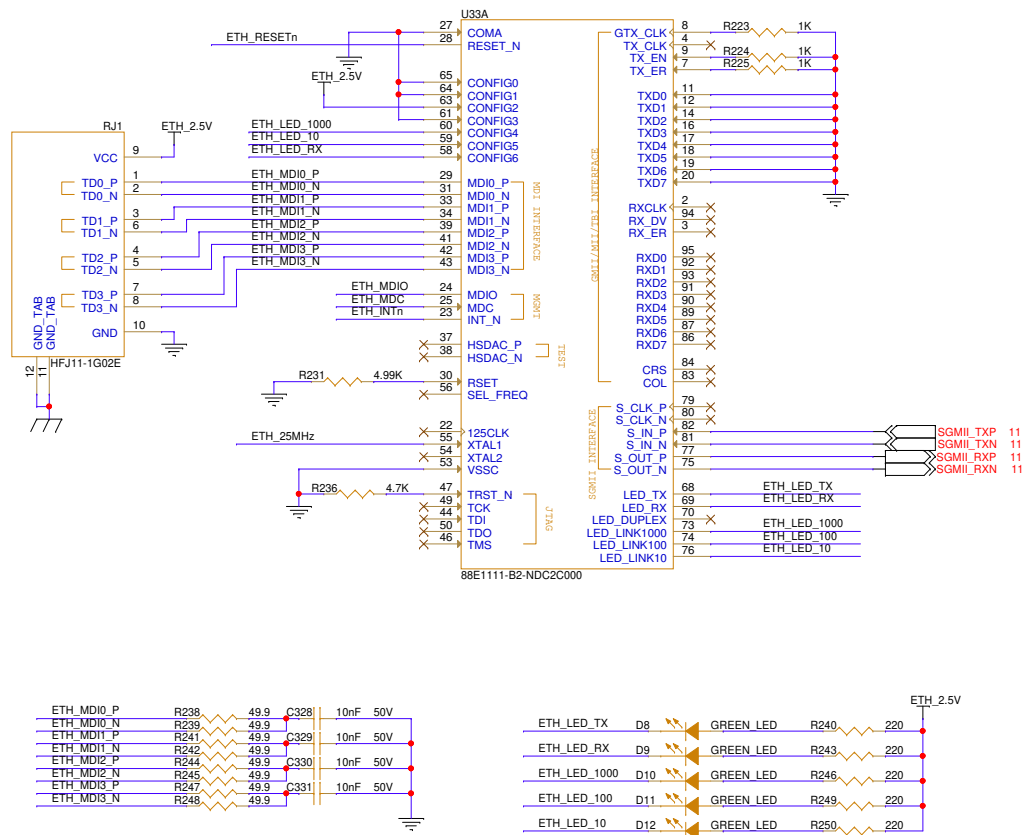

Altera Corporation, 101 Innovation Dr., San Jose CA 95134		
© 2024 Altera Corporation. All Rights Reserved.		
Title CYCLONE 10 GX DEVKIT BOARD (NON-ENP)		
Size	Document Number	Rev
B	M88434-002 (100-0330708-B1)	B
Date:	Thursday, October 24, 2024	Sheet 26 of 49

INTERFACE - GIGE - 2

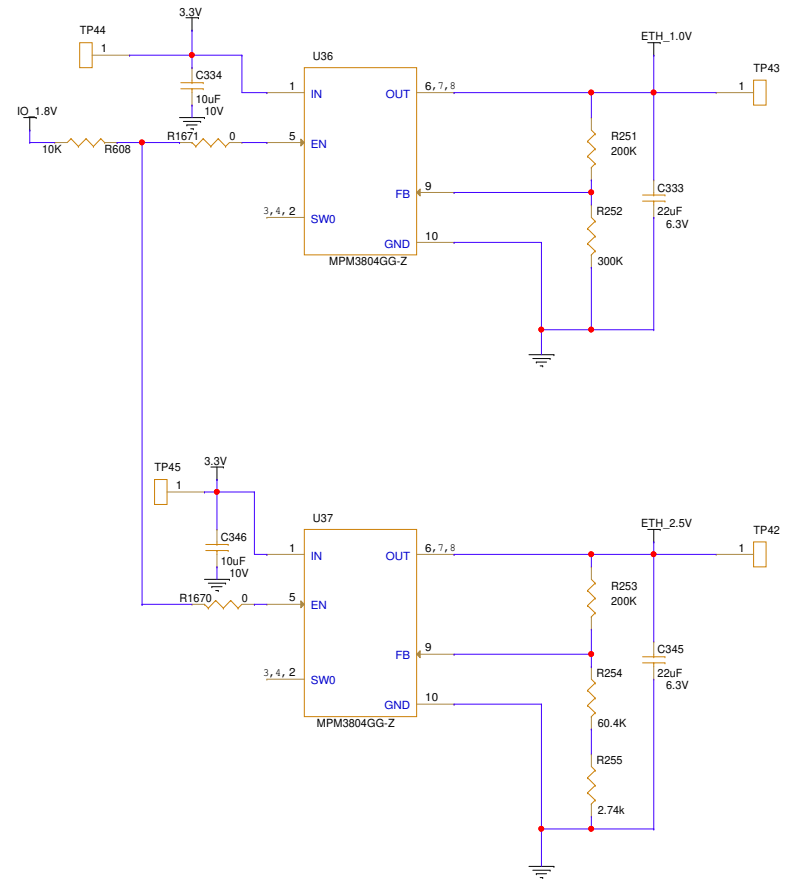
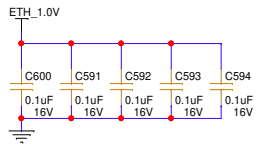
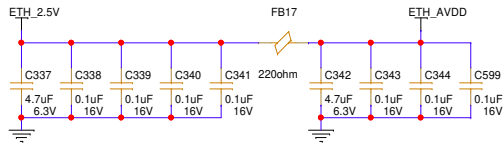
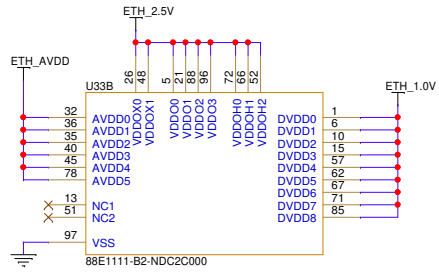

Altera Corporation, 101 Innovation Dr., San Jose CA 95134 © 2024 Altera Corporation. All Rights Reserved.		
Title CYCLONE 10 GX DEVKIT BOARD (NON-ENP)		
Size	Document Number	Rev
B	M88434-002 (100-0330708-B1)	B
Date:	Thursday, October 24, 2024	Sheet 27 of 49

SYS MAX10 - CTRL

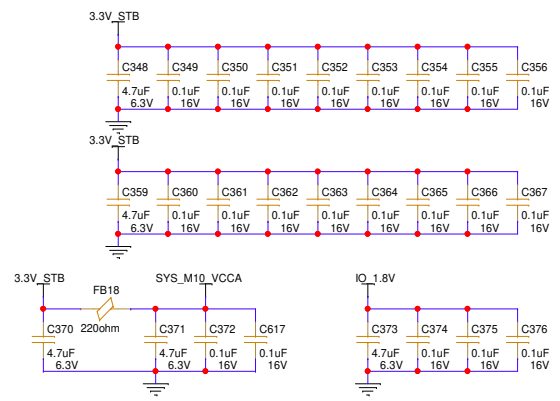
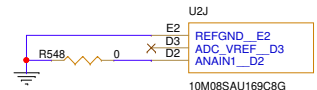
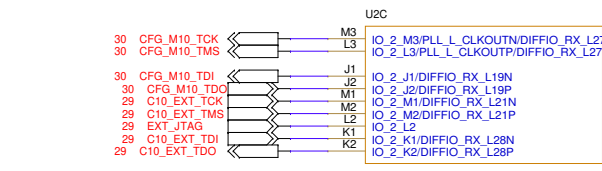
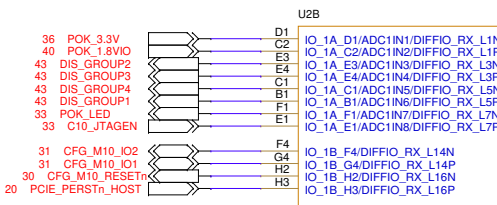
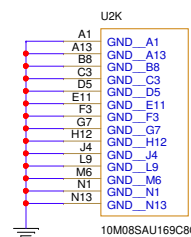
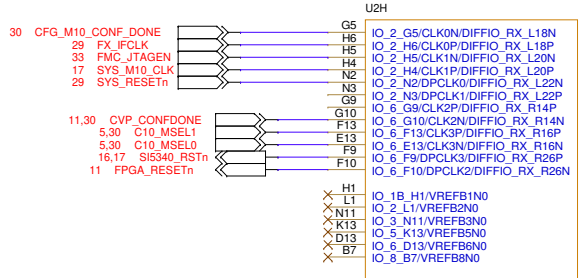
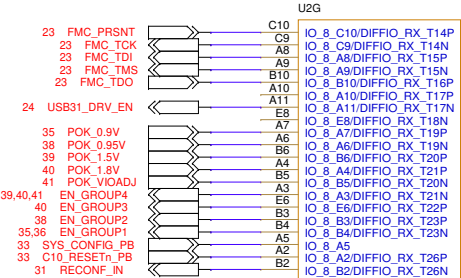
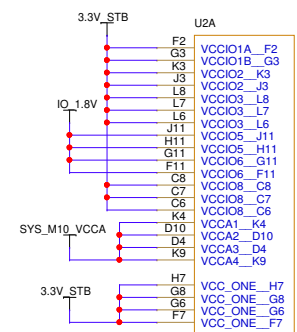
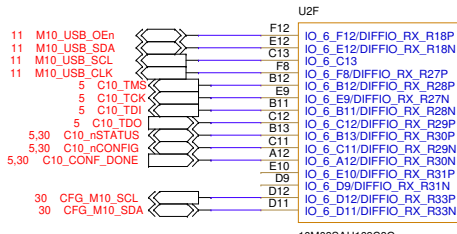
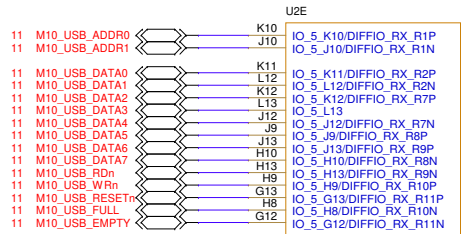

Altera Corporation, 101 Innovation Dr., San Jose CA 95134		
© 2024 Altera Corporation. All Rights Reserved.		
Title CYCLONE 10 GX DEVKIT BOARD (NON-ENP)		
Size	Document Number	Rev
B	M88434-002 (100-0330708-B1)	B
Date:	Thursday, October 24, 2024	Sheet 28 of 43

SYS MAX10 - UBII

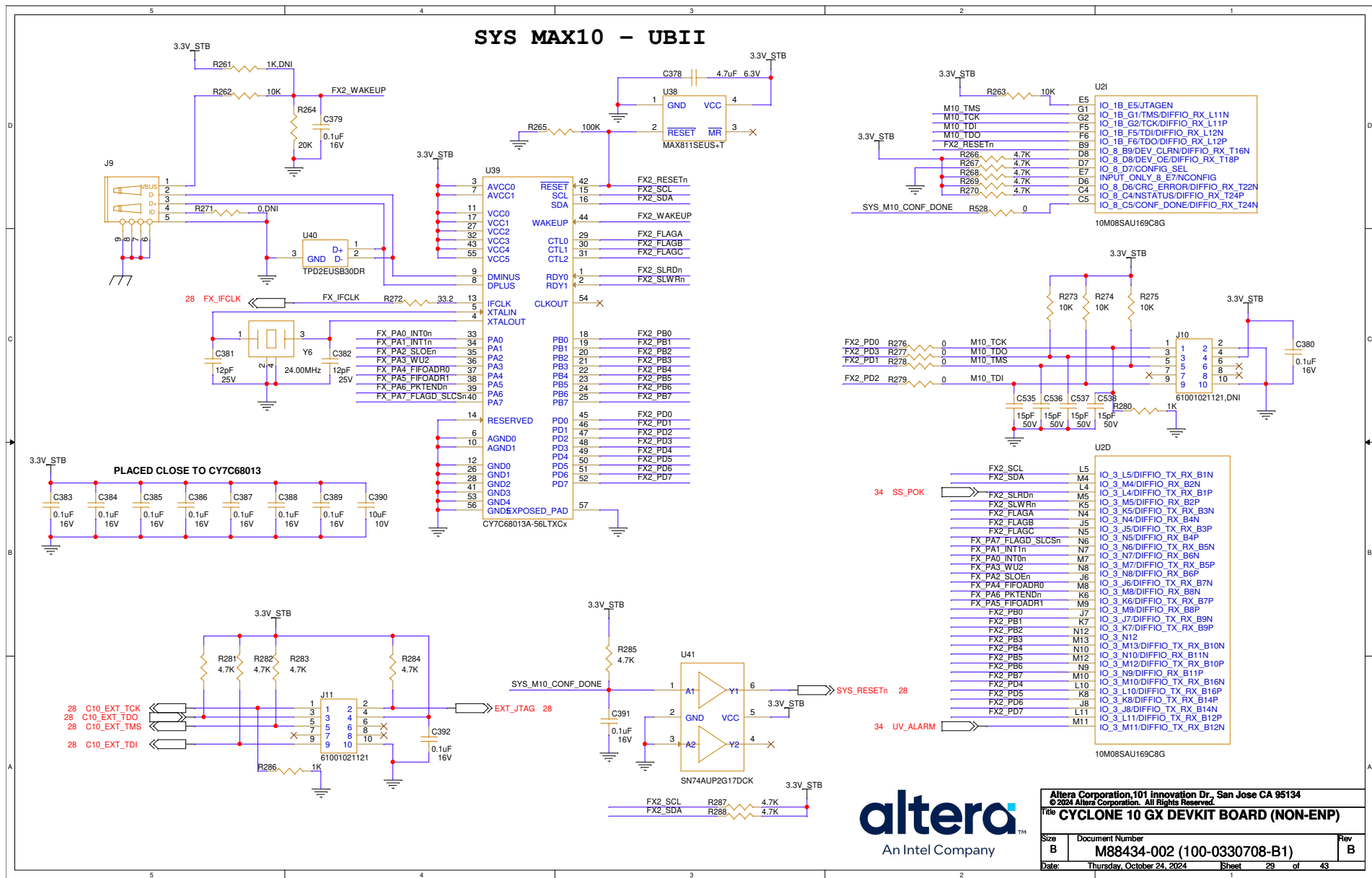

Altera Corporation, 101 Innovation Dr., San Jose CA 95134		
© 2024 Altera Corporation. All Rights Reserved.		
Title CYCLONE 10 GX DEVIK BOARD (NON-ENP)		
Size	Document Number	Rev
B	M88434-002 (100-0330708-B1)	B
Date:	Thursday, October 24, 2024	Sheet 29 of 49

CFG MAX10 - FPP

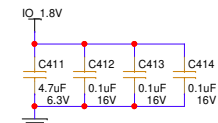
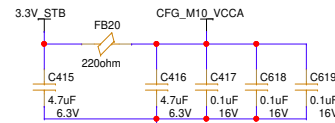
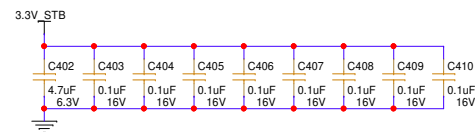
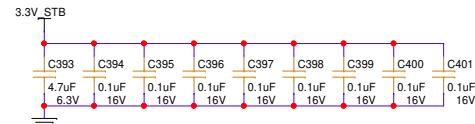
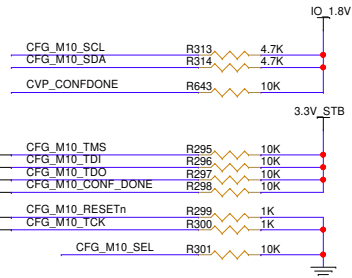
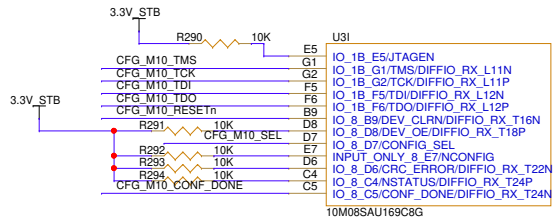
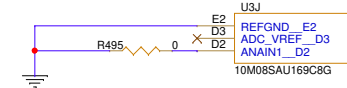
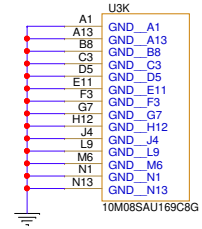
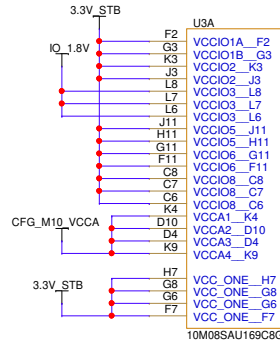
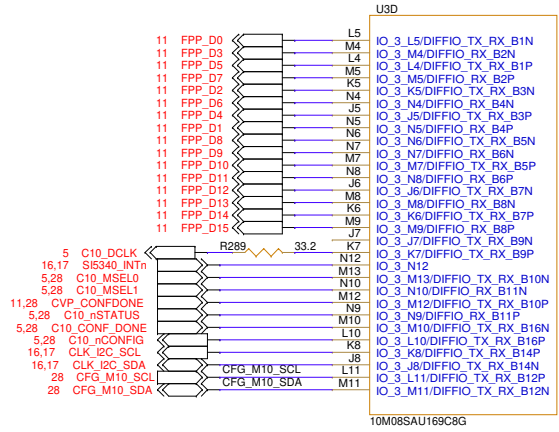

Altera Corporation, 101 Innovation Dr., San Jose CA 95134		
© 2024 Altera Corporation. All Rights Reserved.		
Title CYCLONE 10 GX DEVKIT BOARD (NON-ENP)		
Size	Document Number	Rev
B	M88434-002 (100-0330708-B1)	B
Date:	Thursday, October 24, 2024	Sheet 30 of 49

CFG MAX10 - PFL

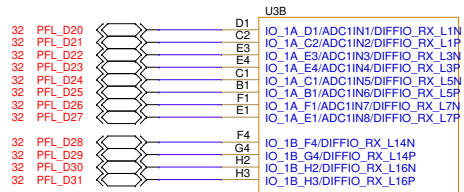

10M08SAU169C8G

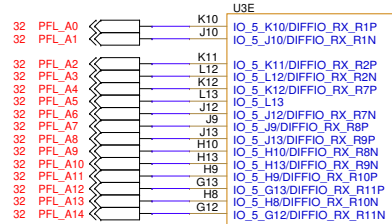

10M08SAU169C8G

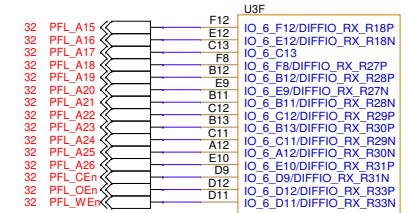

10M08SAU169C8G

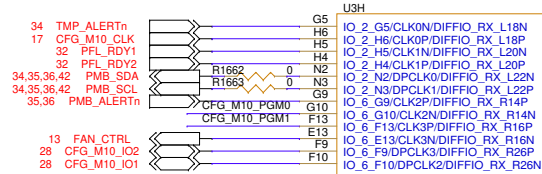

10M08SAU169C8G

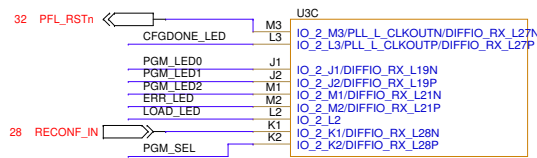

10M08SAU169C8G

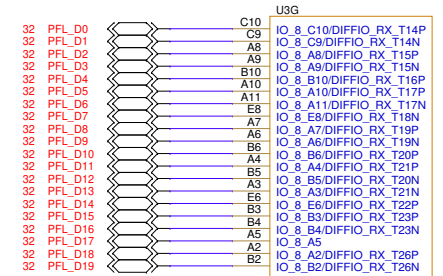

10M08SAU169C8G

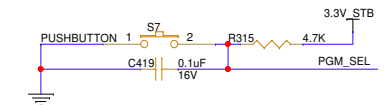
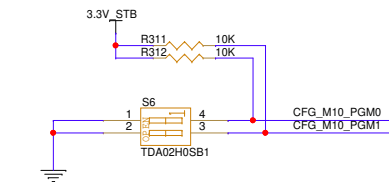
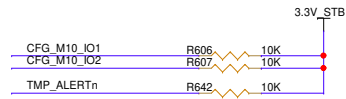
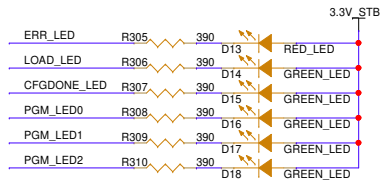

Altera Corporation, 101 Innovation Dr., San Jose CA 95134		
© 2024 Altera Corporation. All Rights Reserved.		
Title CYCLONE 10 GX DEVKIT BOARD (NON-ENP)		
Size	Document Number	Rev
B	M88434-002 (100-0330708-B1)	B
Date:	Thursday, October 24, 2024	Sheet 31 of 49

CFG PFL FLASH

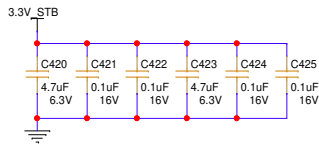
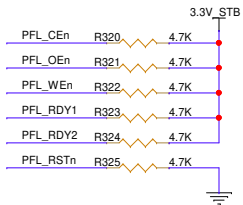
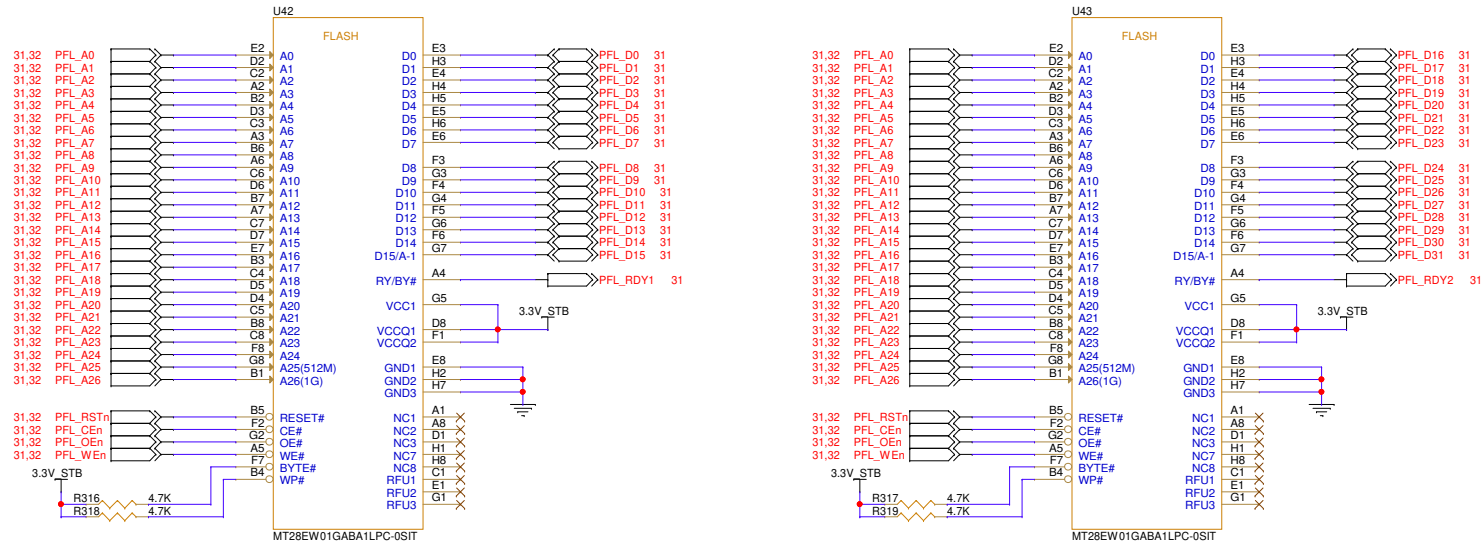

Altera Corporation, 101 Innovation Dr., San Jose CA 95134 © 2024 Altera Corporation. All Rights Reserved.		
Title CYCLONE 10 GX DEVKIT BOARD (NON-ENP)		
Size B	Document Number M88434-002 (100-0330708-B1)	Rev B
Date: Thursday, October 24, 2024	Sheet 1	of 32

LED & PB & SW

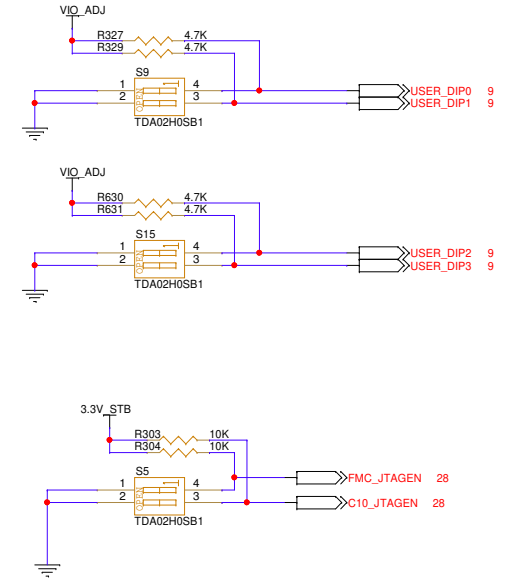
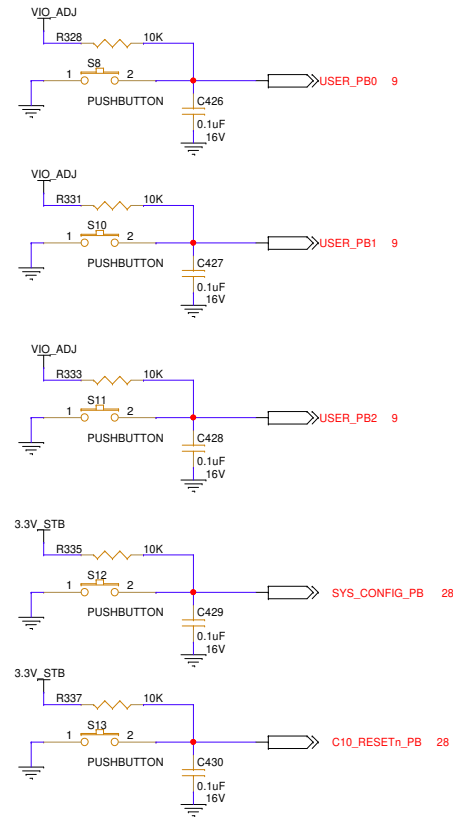
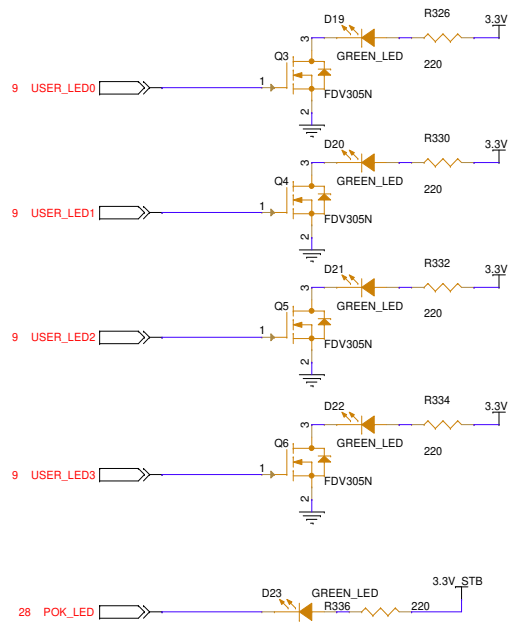

Altera Corporation, 101 Innovation Dr., San Jose CA 95134		
© 2024 Altera Corporation. All Rights Reserved.		
Title CYCLONE 10 GX DEVKIT BOARD (NON-ENP)		
Size	Document Number	Rev
B	M88434-002 (100-0330708-B1)	B
Date:	Thursday, October 24, 2024	Sheet 33 of 49

POWER - INPUT

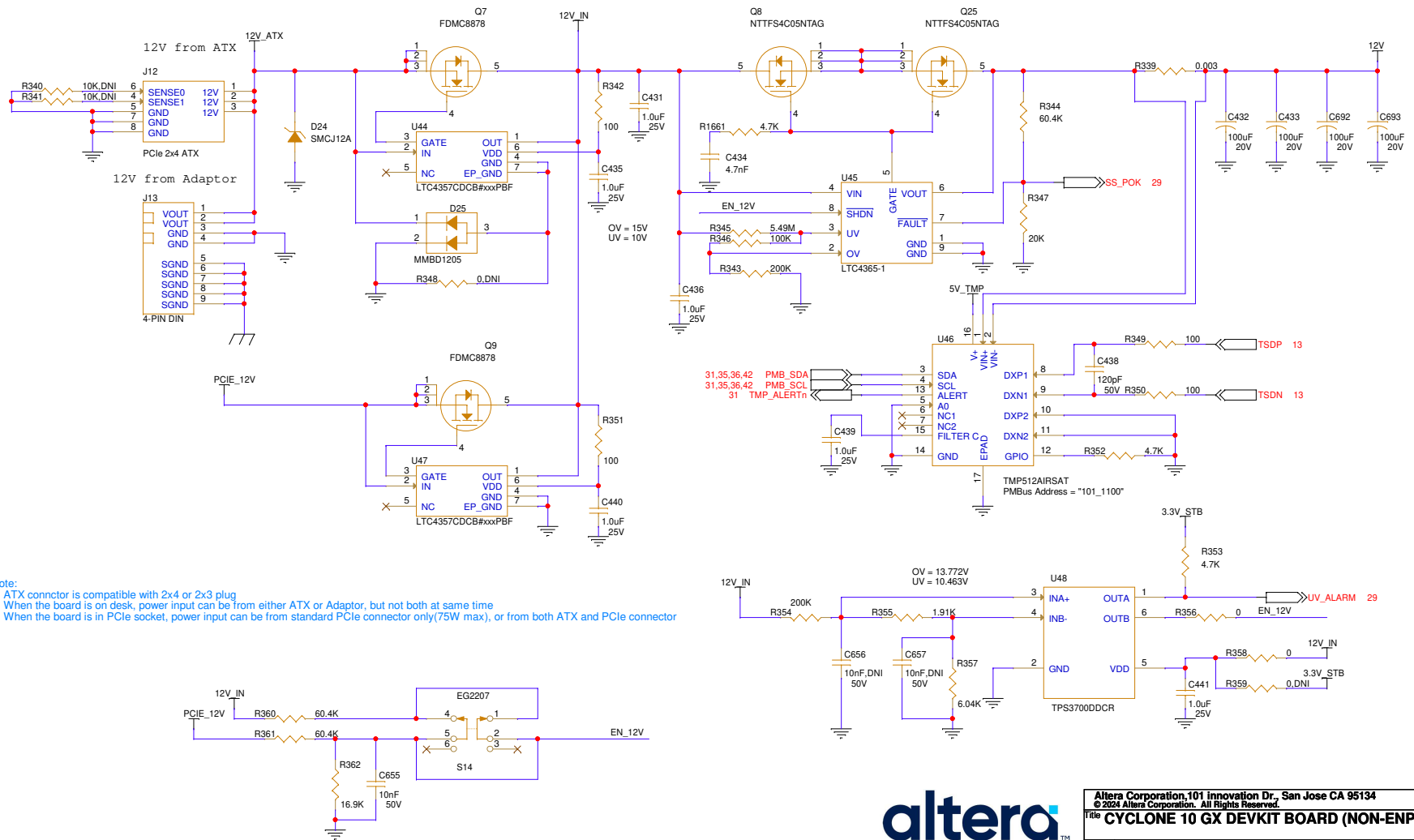

Altera Corporation, 101 Innovation Dr., San Jose CA 95134		
© 2024 Altera Corporation. All Rights Reserved.		
Title CYCLONE 10 GX DEVKIT BOARD (NON-ENP)		
Size	Document Number	Rev
B	M88434-002 (100-0330708-B1)	B
Date:	Thursday, October 24, 2024	Sheet 34 of 49

POWER - 12V to 0.9V

MPM3690GBF-50D-0011

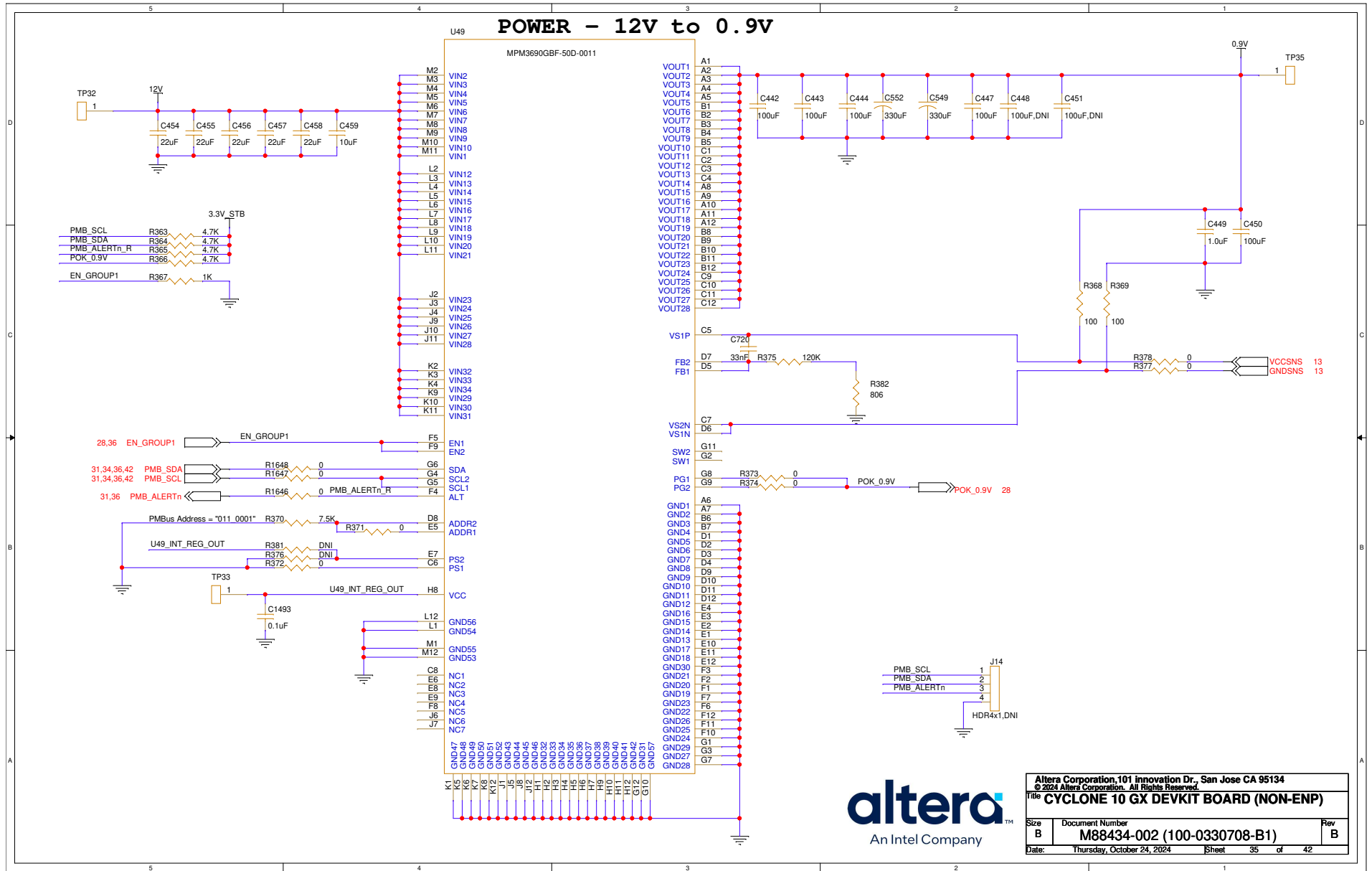

Altera Corporation, 101 Innovation Dr., San Jose CA 95134			
© 2024 Altera Corporation. All Rights Reserved.			
Title CYCLONE 10 GX DEVKIT BOARD (NON-ENP)			
Size	Document Number	Rev	
B	M88434-002 (100-0330708-B1)	B	
Date:	Thursday, October 24, 2024	Sheet	35 of 42

POWER - 12V to 3.3V

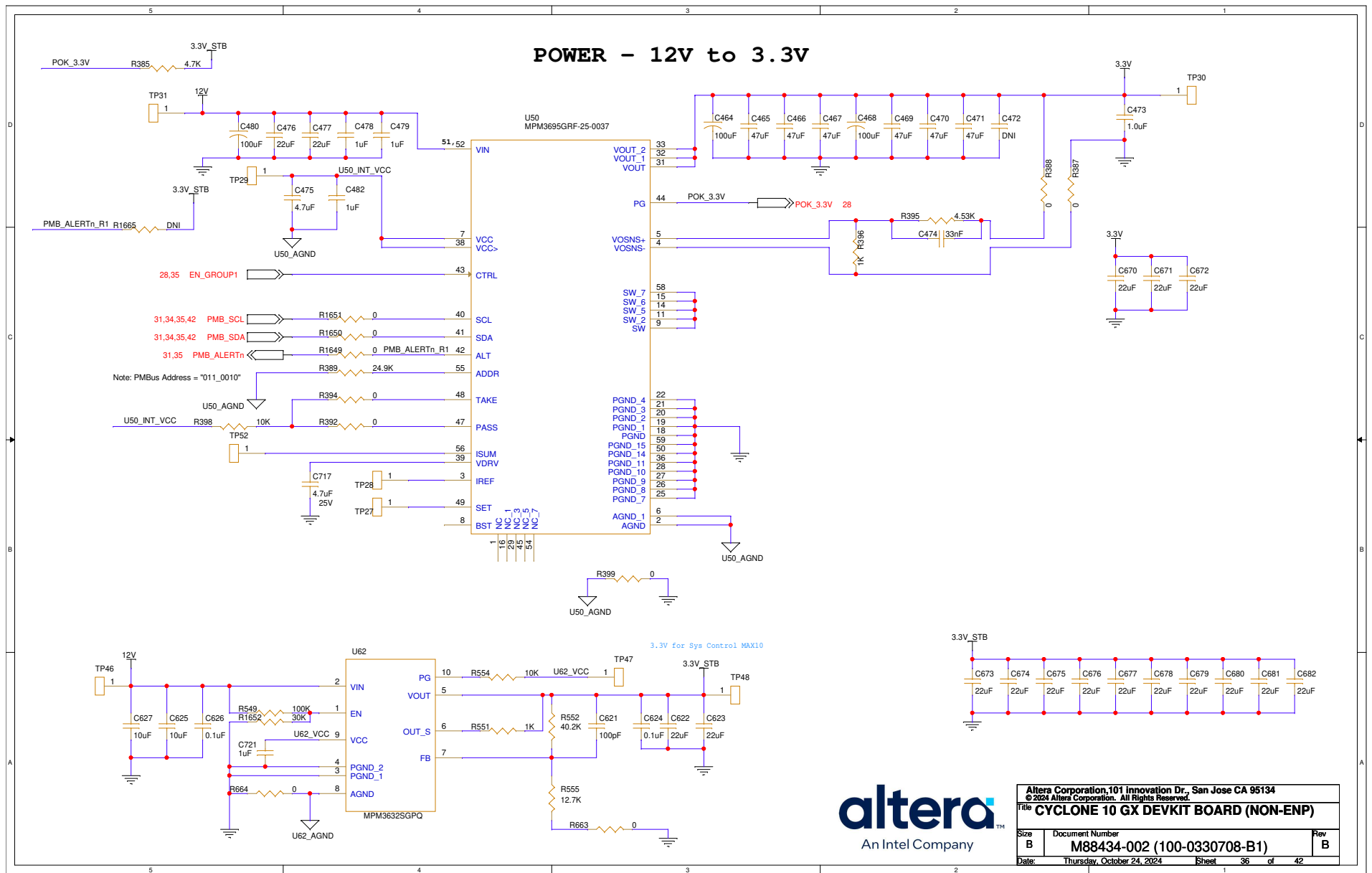

Altera Corporation, 101 Innovation Dr., San Jose CA 95134		
© 2024 Altera Corporation. All Rights Reserved.		
Title CYCLONE 10 GX DEVKIT BOARD (NON-ENP)		
Size	Document Number	Rev
B	M88434-002 (100-0330708-B1)	B
Date:	Thursday, October 24, 2024	Sheet 36 of 42

POWER - 12V to 5V

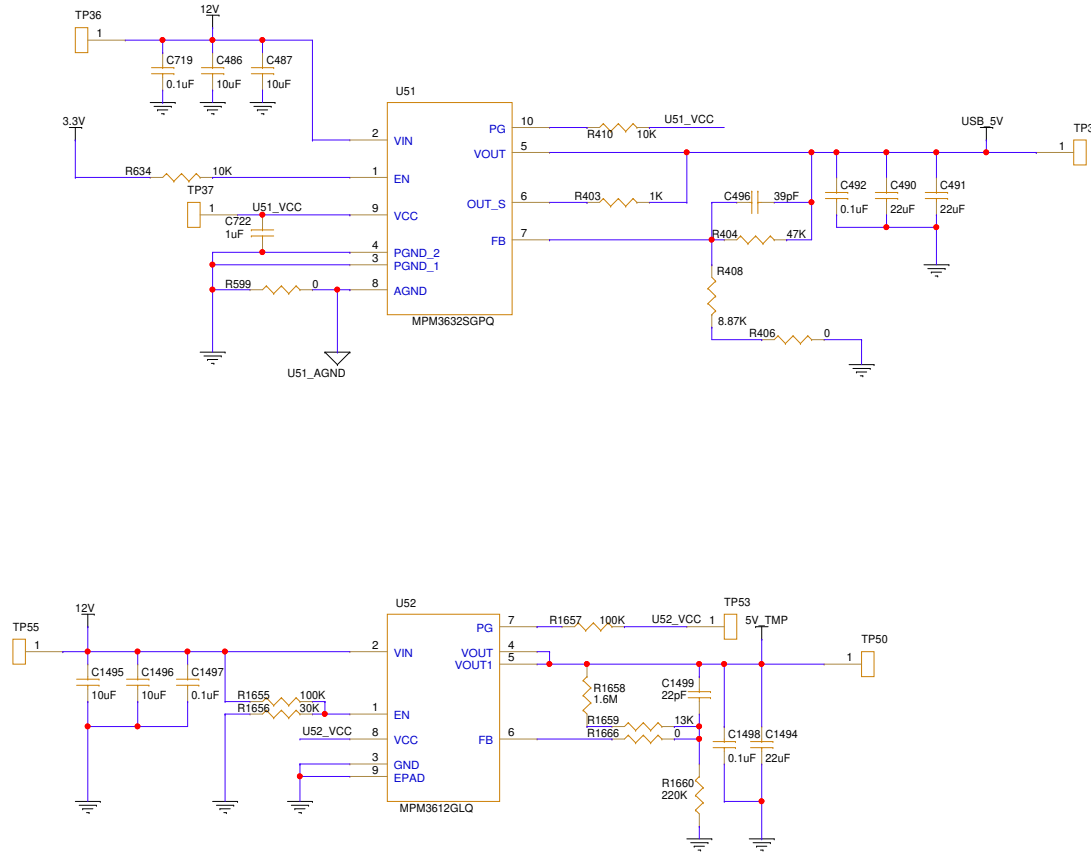

Altera Corporation, 101 innovation Dr., San Jose CA 95134		
© 2024 Altera Corporation. All Rights Reserved.		
Title CYCLONE 10 GX DEVKIT BOARD (NON-ENP)		
Size	Document Number	Rev
B	M88434-002 (100-0330708-B1)	B
Date:	Thursday, October 24, 2024	Sheet 37 of 42

POWER - 12V to 1.8V

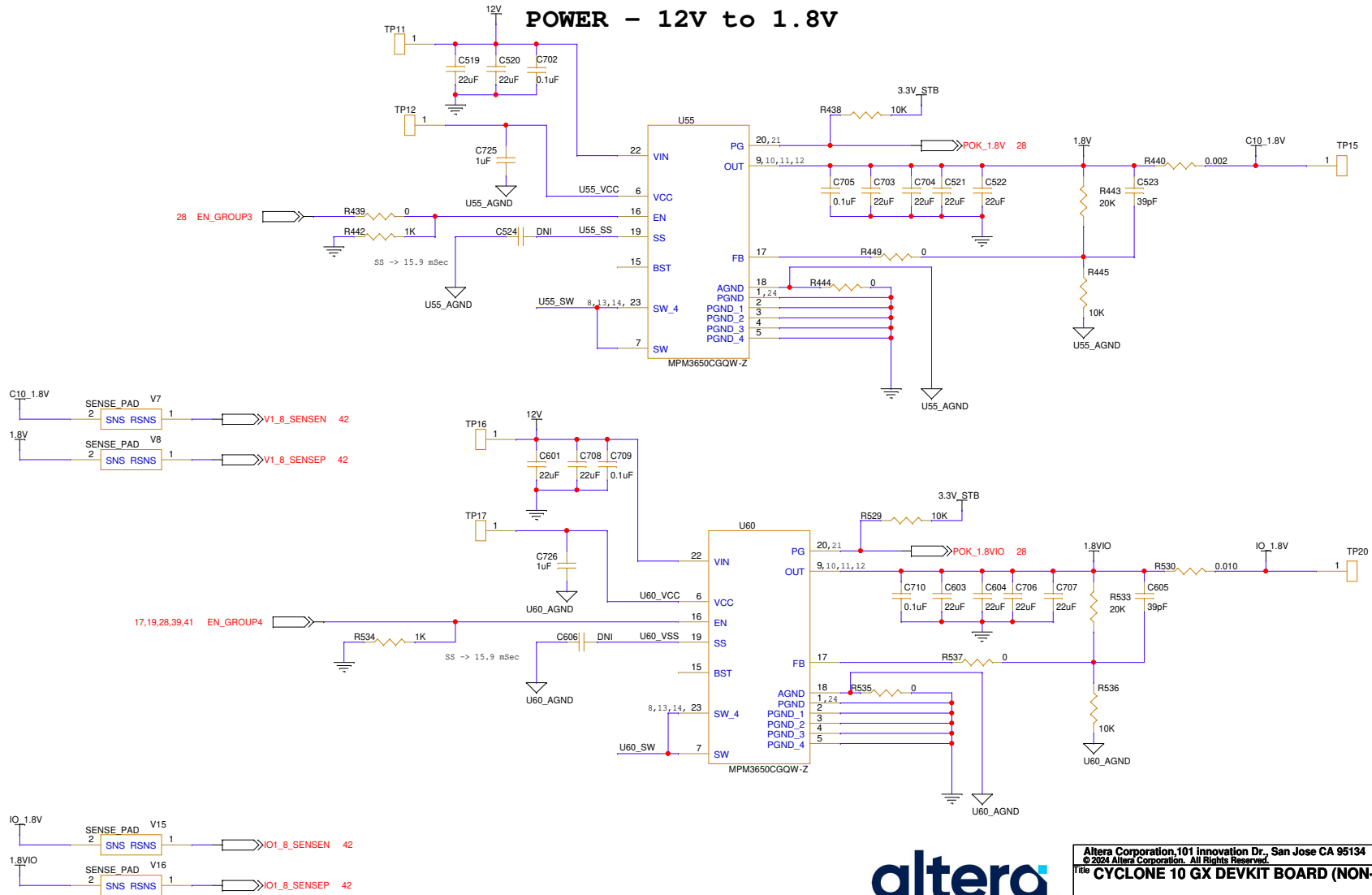

Altera Corporation, 101 Innovation Dr., San Jose CA 95134		
© 2024 Altera Corporation. All Rights Reserved.		
Title CYCLONE 10 GX DEVKIT BOARD (NON-ENP)		
Size	Document Number	Rev
B	M88434-002 (100-0330708-B1)	B
Date:	Thursday, October 24, 2024	Sheet 40 of 42

POWER - 12V to VADJ

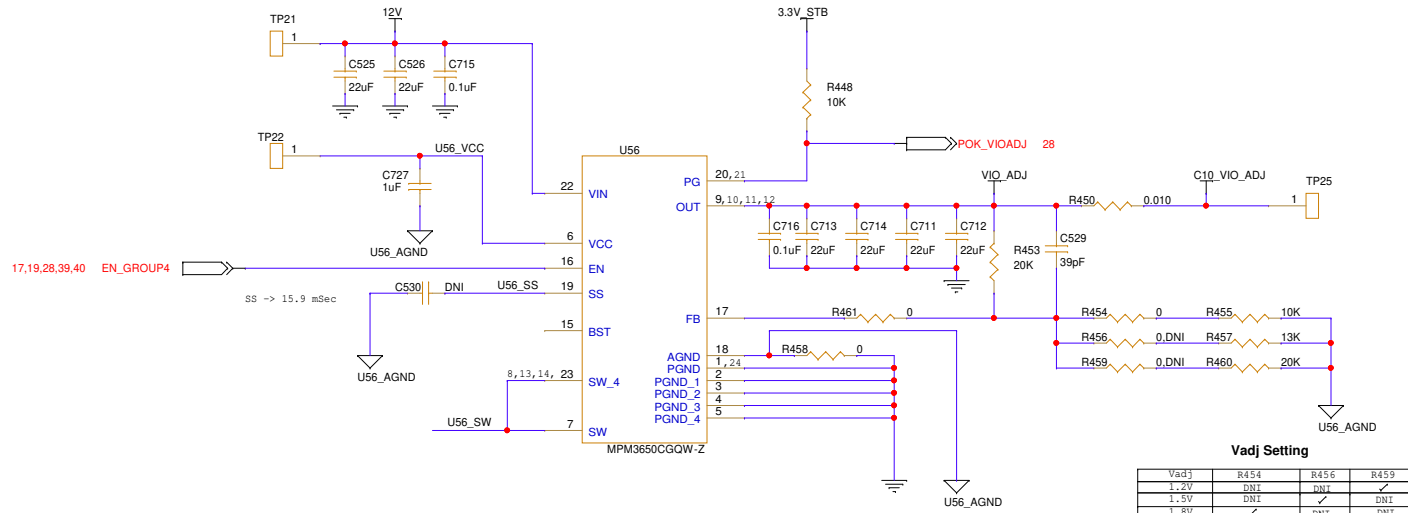

Vadj Setting

Vadj	R454	R456	R459
1.2V	DNI	DNI	✓
1.5V	DNI	✓	DNI
1.8V	✓	DNI	DNI

NOTE: ✓ indicates 0 ohm

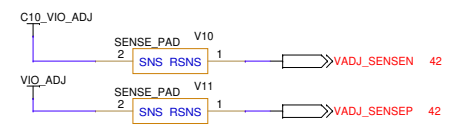

Altera Corporation, 101 innovation Dr., San Jose CA 95134			
© 2024 Altera Corporation. All Rights Reserved.			
Title CYCLONE 10 GX DEVKIT BOARD (NON-ENP)			
Size	Document Number	Rev	
B	M88434-002 (100-0330708-B1)	B	
Date:	Thursday, October 24, 2024	Sheet	41 of 42

POWER - CURRENT SENSE

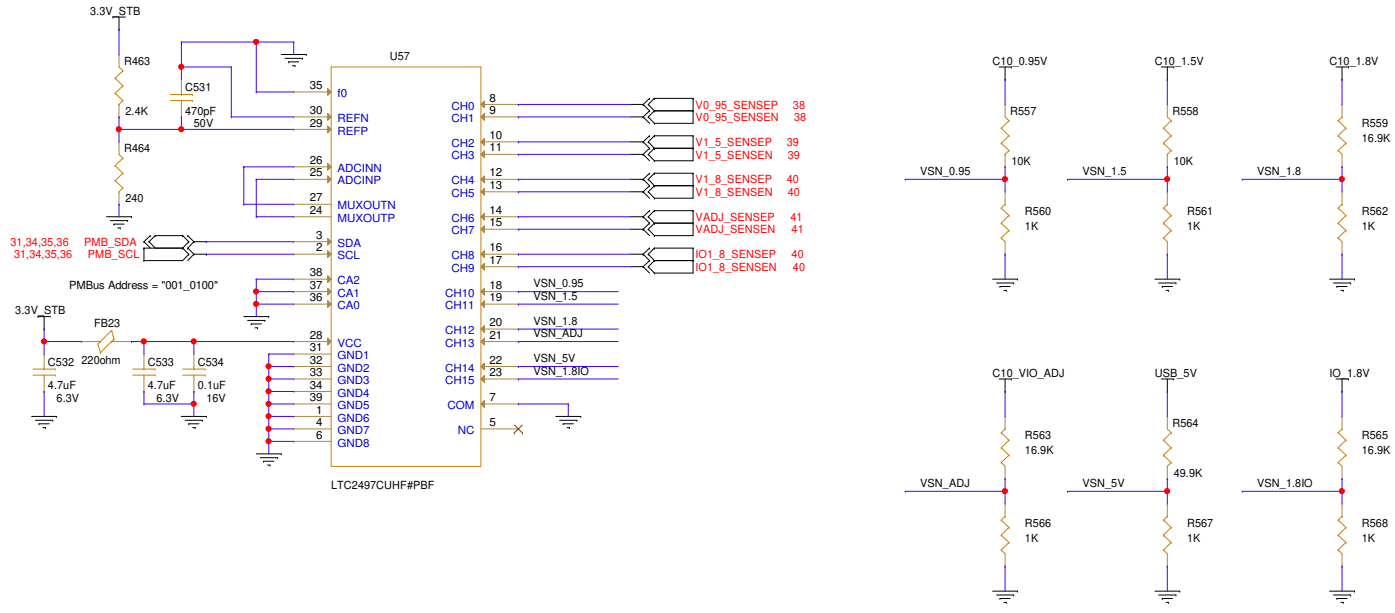

Altera Corporation, 101 Innovation Dr., San Jose CA 95134		
© 2024 Altera Corporation. All Rights Reserved.		
Title CYCLONE 10 GX DEVKIT BOARD (NON-ENP)		
Size	Document Number	Rev
B	M88434-002 (100-0330708-B1)	B
Date:	Thursday, October 24, 2024	Sheet 42 of 49

POWER - Fast Discharge

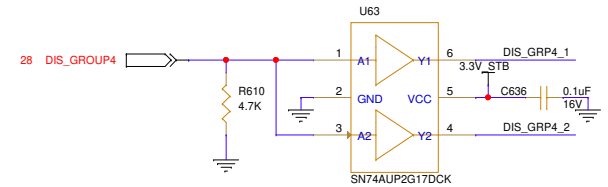
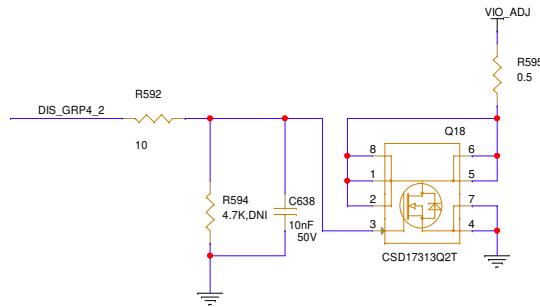
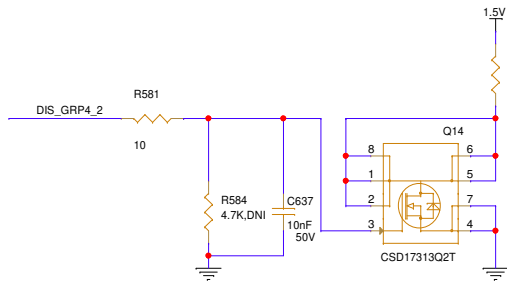
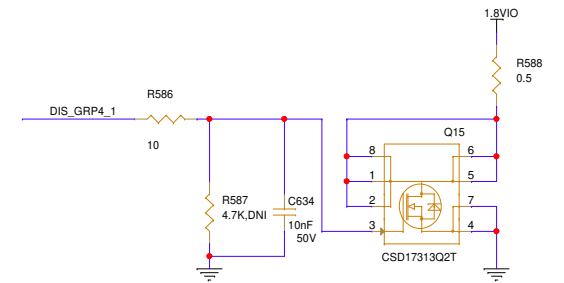
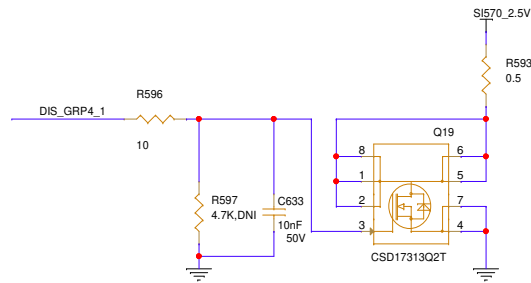
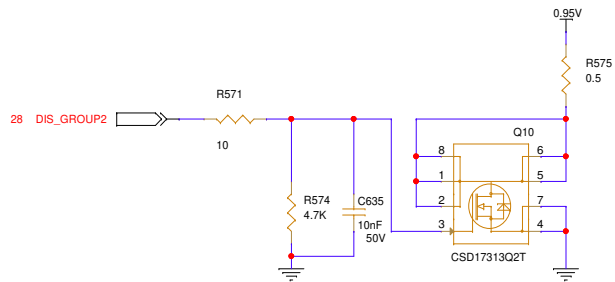
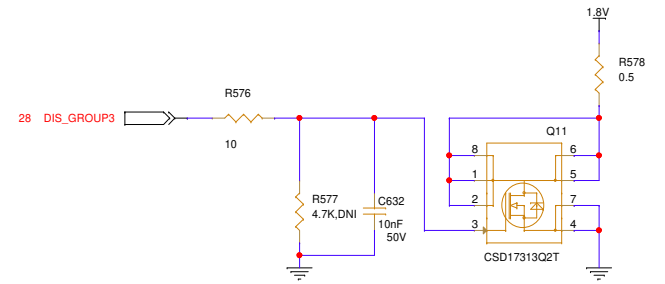
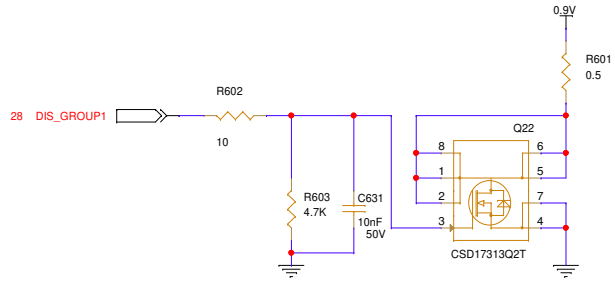

Altera Corporation, 101 Innovation Dr., San Jose CA 95134		
© 2024 Altera Corporation. All Rights Reserved.		
Title CYCLONE 10 GX DEVKIT BOARD (NON-ENP)		
Size	Document Number	Rev
B	M88434-002 (100-0330708-B1)	B
Date:	Thursday, October 24, 2024	Sheet 43 of 43