



Intel® Server System M50FCP1UR

Technical Product Specification

An overview of product features, functions, architecture, and support specifications.

Rev. 1.6

June 2024



M50FCP1UR

Delivering Breakthrough Data Center System Innovation – Experience What's Inside!

<This page intentionally left blank>

Document Revision History

Date	Revision	Changes
January 2023	1.0	Production Release
January 2023	1.1	<ul style="list-style-type: none"> • Edits made to Figure #3 • Edits made to section 2.6 cable routing • Section 4.1 Thermal Operation and Config requirements updated • Correction made in section 5.1 page 43. Riser card assembly installation figure and text. • Section 5.3 OCP add in card support updated • Section 6.1 Front Drive Bay support updated
February 2023	1.2	<ul style="list-style-type: none"> • Adding Intel® VROC information • Remove Intel® Optane™ PMem 300 Series support • Updating Table 27. Supported Video Resolutions • Minor updates for clarity
May 2023	1.3	<ul style="list-style-type: none"> • Updating Table 3. System Environmental Limits Summary • Adding Appendix B. Software License Key Order, Registration, and Installation • Minor updates for clarity
September 2023	1.4	<ul style="list-style-type: none"> • Edits made to Figure 11. System Configuration and Recovery Jumpers • Updating tables in Appendix D. System Configuration Table for Thermal Compatibility, OCP power max supported. • Updating Appendix B. Software License Key Management • Minor updates for clarity
February 2024	1.5	<ul style="list-style-type: none"> • Add 5th Gen Intel® Xeon® Scalable processor family support information • Updating Appendix D System Configuration Table for Thermal Compatibility • Update Figure 7. Intel® Server Board M50FCP2SBSTD Architectural Block Diagram • Update Figure 30 PCIe Subsystem Architecture
June 2024	1.6	<ul style="list-style-type: none"> • Updating Appendix D System Configuration Table for Thermal Compatibility • Edits made to Figure 7. Intel® Server Board M50FCP2SBSTD Architectural Block Diagram • Minor Updates for clarity

Disclaimers

Intel technologies' features and benefits depend on system configuration and may require enabled hardware, software, or service activation. Performance varies depending on system configuration. No computer system can be absolutely secure. Check with your system manufacturer or retailer or learn more at intel.com.

You may not use or facilitate the use of this document in connection with any infringement or other legal analysis concerning Intel products described herein. You agree to grant Intel a non-exclusive, royalty-free license to any patent claim thereafter drafted which includes subject matter disclosed herein.

No license (express or implied, by estoppel or otherwise) to any intellectual property rights is granted by this document.

The products described may contain design defects or errors known as errata which may cause the product to deviate from published specifications. Current characterized errata are available on request.

Intel disclaims all express and implied warranties, including without limitation, the implied warranties of merchantability, fitness for a particular purpose, and non-infringement, as well as any warranty arising from course of performance, course of dealing, or usage in trade.

Copies of documents which have an order number and are referenced in this document may be obtained by calling 1-800-548-4725 or by visiting www.intel.com/design/literature.htm.

Intel, Xeon, Intel Optane, and the Intel logo are trademarks of Intel Corporation or its subsidiaries in the U.S. and/or other countries.

*Other names and brands may be claimed as the property of others.

© Intel Corporation

Table of Contents

1. Introduction	13
1.1 Reference Documents	14
2. Server System Overview	16
2.1 Server System Feature Set	17
2.2 System Feature Identification	20
2.3 Server Board Features	22
2.4 System Dimensions and Labeling Options	26
2.5 System Top Cover	28
2.6 System Cable Routing Channels	30
2.7 Available Rack and Cabinet Mounting Kit Options	31
2.8 System Level Environmental Limits	33
2.9 System Packaging	34
3. System Power	35
3.1 Power Supply Configurations	36
3.1.1 Single Power Supply (1+0) Power Configuration	36
3.1.2 Dual Power Supply 1+1 Power Configuration	36
3.1.3 Dual Power Supply 2+0 Power Configuration	36
3.2 Intel® Online Power Calculator Tool	37
3.3 Closed Loop System Throttling (CLST)	37
3.4 Smart Ride Through (SmaRT) Throttling	37
3.5 Power Supply Cold Redundancy	37
3.6 Power Supply Specification Overview	38
3.6.1 Power Supply Module Efficiency	38
3.6.2 AC Power Cord Specifications	38
3.7 AC Power Supply Features	39
3.7.1 Power Supply Status LED	39
3.7.2 Protection Circuits	39
4. Thermal Management Overview	41
4.1 Thermal Operation and Configuration Requirements	43
4.2 Thermal Management Overview	44
4.3 System Fans	45
4.4 Power Supply Module Fans	45
4.5 Fan Speed Control	46
4.6 Processor Heat Sink Options	46
5. PCI Express* (PCIe*) Subsystem Overview	47
5.1 PCIe* Riser Card Support	49
5.2 PCIe* Riser Card Options	51
5.2.1 1-Slot PCIe* Riser Card for Riser Slot #1 (iPC FCP1URISER1)	51
5.2.2 1-Slot PCIe* Riser Card for Riser Slot #2 (iPC FCP1URISER2)	51
5.2.3 1-Slot PCIe* MCIO Riser Card for Riser Slot #2 with PCIe Interposer Riser Card Support	52

5.3	Intel® Ethernet Network Adapter for OCP* Support.....	54
6.	System Storage.....	56
6.1	Front Drive Bay Support.....	56
6.1.1	Front Drive Bay LED Support	58
6.2	Hot Swap Backplane (HSBP) Overview	59
6.2.1	SGPIO Functionality	60
6.2.2	I ² C Functionality.....	60
6.2.3	Power Supply Connector	61
6.2.4	4 x 2.5" Drive SATA/SAS/NVMe* Combo Backplane (iPC CYPHSBP1204).....	61
6.2.5	12 x 2.5" Drive SATA/SAS/NVMe* Combo Backplane.....	62
6.3	NVMe* Storage Support.....	64
6.3.1	PCIe* Mini Cool Edge IO (MCIO*) Connector Support	64
6.3.2	Intel® Volume Management Device (Intel® VMD) 3.0 for NVMe*	64
6.3.3	Intel® Virtual RAID on CPU for NVMe (Intel® VROC for NVMe) 8.0	66
6.3.4	NVMe* Drive Population Rules for Intel® VROC 8.0.....	67
6.4	Server Board SATA Support.....	69
6.4.1	Staggered Disk Spin-Up	70
6.4.2	Intel® Virtual RAID on CPU SATA 8.0 (Intel® VROC SATA).....	70
6.5	SAS Storage Support.....	72
6.6	M.2 SSD Storage Support.....	72
7.	Front Control Panel and I/O.....	73
7.1	Control Panel Features	73
7.2	Front I/O Features.....	76
7.3	Rear I/O Features.....	76
7.3.1	Remote Management Port	76
7.3.2	Serial Port A Support.....	77
7.3.3	USB Support.....	78
7.3.4	Video Support	78
8.	Intel® Light-Guided Diagnostics.....	80
8.1	Post Code Diagnostic LEDs.....	80
8.2	System ID LED	81
8.3	System Status LED.....	82
8.3.1	BMC Boot/Reset Status LED Indicators	82
8.4	Processor Fault LEDs.....	82
8.5	Memory Fault LEDs	83
8.6	Fan Fault LEDs.....	84
8.7	Additional Light Guided Diagnostics.....	84
8.7.1	Power Supply Status LED	84
8.7.2	Front Panel Control LED Indicators.....	84
8.7.3	Drive Bay LEDs.....	84
8.7.4	Drive Activity LED for Front Control Panel.....	84
Appendix A.	Getting Help.....	85

Appendix B. Software License Key Management.....	86
B.1 Ordering Software License Key	86
B.2 Order and Register a License Key as an Add-on Accessory (Not via CTO)	86
B.3 Software License Key Installation	89
B.3.1 Installation Using the Integrated BMC Web Console	89
B.3.2 Installation Using the Intel® Server Configuration Utility	90
B.3.3 Installation Using Redfish*.....	91
Appendix C. Integration and Usage Tips.....	93
Appendix D. System Configuration Table for Thermal Compatibility.....	94
C.1 Normal Operating Mode/Fan Fail Mode with Dual Processor Installed.....	97
C.2 Normal Operating Mode/Fan Fail Mode with Single Processor Installed	110
Appendix E. System Sensors.....	120
Appendix F. Statement of Volatility.....	122
Appendix G. Product Regulatory Compliance.....	124
Appendix H. Glossary	129

List of Figures

Figure 1. Intel® Server System M50FCP1UR.....	13
Figure 2. Intel® Server System M50FCP1UR System Views	16
Figure 3. Server System Components Overview.....	20
Figure 4. Back Panel Feature Identification.....	20
Figure 5. Front Panel Feature Identification	21
Figure 6. System with Optional Front Bezel.....	21
Figure 7. Intel® Server Board M50FCP2SBSTD Architectural Block Diagram	22
Figure 8. Intel® Server Board M50FCP2SBSTD Component / Feature Identification.....	23
Figure 9. Intel® Light-Guided Diagnostics – LED Identification	24
Figure 10. Intel® Light-Guided Diagnostics – Memory Fault LEDs.....	24
Figure 11. System Configuration and Recovery Jumpers.....	25
Figure 12. System Dimensions	26
Figure 13. Label Emboss Dimensions.....	26
Figure 14. Pull-out Tab Location.....	27
Figure 15. Pull-out Fab Label Emboss Dimensions	27
Figure 16. System Top Cover Shipping Screws.....	28
Figure 17. System Top Cover Removal.....	28
Figure 18. System Top Cover Installation.....	29
Figure 19. System Cable Routing Channels	30
Figure 20. Rear Panel Shipping Screw Holes.....	32
Figure 21. Power Supply Module Identification.....	35
Figure 22. Power Supply Module Partially Out of Chassis.....	35
Figure 23. Power Supply Module	35
Figure 24. AC Power Cable Connector	38
Figure 25. AC Power Cord Specification.....	39
Figure 26. System Airflow and Fan Identification.....	41
Figure 27. System Memory Module / DIMM Blanks Configuration	43
Figure 28. System Fan Assembly.....	45
Figure 29. Supported Processor Heat Sinks.....	46
Figure 30. PCIe Subsystem Architecture.....	47
Figure 31. PCIe* Riser Card Slot Identification.....	49
Figure 32. Riser Card Assembly Components.....	49
Figure 33. Add-in Card Placement into Server System Chassis.....	50
Figure 34. PCIe Add-in Card Support	50
Figure 35. PCIe* Riser Card for Riser Slot #1	51
Figure 36. PCIe* Riser Card for Riser Slot #2	51
Figure 37. PCIe* Riser Card for Riser Slot #2	52
Figure 38. PCIe* Interposer Riser Card.....	53
Figure 39. PCIe* Interposer Riser Card to PCIe* Riser Card Connectivity.....	53
Figure 40. Intel® Ethernet Network Adapter for OCP* Placement.....	54

Figure 41. OCP* Bay Filler Removal.....	54
Figure 42. OCP* Add-in Card with Pull Tab Installation	55
Figure 43. OCP* Adapter with Internal Lock Installation.....	55
Figure 44. Internal Lock with Unlock and Lock Orientation.....	55
Figure 45. 4 x 2.5" Front Drive Bay Configuration – M50FCP1UR204	56
Figure 46. 12 x 2.5" Front Drive Bay Configuration – M50FCP1UR212	56
Figure 47. 2.5" Drive Bay Components	57
Figure 48. Separating a drive blank.....	57
Figure 49. 7mm SSD Support	57
Figure 50. Drive Installation.....	58
Figure 51. Drive Removal from Drive Bay	58
Figure 52. Drive Bay LED Identification.....	58
Figure 53. 4 x 2.5" Hot Swap Backplane Placement.....	59
Figure 54. 12 x 2.5" Hot Swap Backplane Placement.....	60
Figure 55. Server Board HSBP Power Connector	61
Figure 56. 4 x 2.5" SAS/SATA/NVMe* Hot Swap Backplane – Front Side	61
Figure 57. 4 x 2.5" SAS/SATA/NVMe* Hot Swap Backplane – Back Side	62
Figure 58. 12 x 2.5" SAS/SATA/NVMe* Hot Swap Backplane – Front Side	62
Figure 59. 12 x 2.5" SAS/SATA/NVMe* Hot Swap Backplane – Back Side.....	63
Figure 60. PCIe* MCIO Connectors	64
Figure 61. NVMe* Storage Bus Event / Error Handling.....	64
Figure 62. Supported NVMe* Configurations – Windows* and Linux*	66
Figure 63. 4 x 2.5" SAS/SATA/NVMe* Hot Swap Backplane – Front side.....	67
Figure 64. 4 x 2.5" SAS/SATA/NVMe* Hot Swap Backplane – Back Side	68
Figure 65. 12 x 2.5" SAS/SATA/NVMe* Hot Swap Backplane – Front Side	68
Figure 66. 12 x 2.5" SAS/SATA/NVMe* Hot Swap Backplane – Back Side.....	68
Figure 67. Onboard SATA Cable Connectors and M.2 SSD Connectors.....	69
Figure 68. Front Control Panel Features	73
Figure 69. Front I/O Features	76
Figure 70. Rear I/O Features.....	76
Figure 71. Remote Management Port.....	77
Figure 72. Serial Port A	77
Figure 73. RJ45 Serial Port A Pin Orientation	77
Figure 74. External USB 2.0 and 3.0 Connector Ports	78
Figure 75. Exploded View of POST Code Diagnostic, System ID, and System Status LEDs	80
Figure 76. System ID LED / Button.....	81
Figure 77. Processor Fault LEDs	83
Figure 78. Memory Fault LED Location.....	83
Figure 79. System Fan Fault LEDs.....	84
Figure 80. Example Email.....	86
Figure 81. Register Key	87
Figure 82. Activate Key for Advanced System Management (ASM) Key.....	87

Figure 83. Activate Key for Intel® Virtual RAID on CPU Standard/Premium Software Key	88
Figure 84. Integrated BMC Web Console Advanced System Management Key Page.....	89
Figure 85. BMC Web Console System Information Page	90
Figure 86. Upload VROC Standard License Key Using SYSCFG Utility.....	91
Figure 87. Confirm Activation of VROC Standard License Key Using SYSCFG Utility.....	91
Figure 88. Redfish Command to Upload the VROC Premium Software License Key.....	92
Figure 89. Redfish Command to verify the activation status of the VROC Software License Key	92
Figure 90. PCIe SIG Add-in cards thermal levels	96
Figure 91. Server Board Sensor Map	120
Figure 92. Server System Sensor Map	121

List of Tables

Table 1. Intel® Server M50FCP Family Reference Documents and Support Collaterals.....	14
Table 2. Intel® Server System M50FCP1UR Features	17
Table 3. System Environmental Limits Summary.....	33
Table 4. 1,300 W and 1,600 W AC Power Supply Option Efficiency (80 PLUS* Titanium).....	38
Table 5. AC power Cord Specifications.....	39
Table 6. LED Indicators.....	39
Table 7. Over Current Protection for 1,300 W Power Supplies.....	39
Table 8. Over Current Protection for 1,600 W Power Supplies.....	40
Table 9. Over Voltage Protection (OVP) Limits, 1,300 W and 1,600 W Power Supply.....	40
Table 10. System Volumetric Airflow – M50FCP1UR204	41
Table 11. System Volumetric Airflow – M50FCP1UR212	42
Table 12. Processor / Chipset PCIe* Port Routing	48
Table 13. PCIe* Riser Card Connector Description.....	51
Table 14. PCIe* Riser Card Connector Description.....	52
Table 15. PCIe* Riser Card Connector Description.....	52
Table 16. PCIe* Interposer Riser Card Connector Description	53
Table 17. Drive Status LED States.....	59
Table 18. Drive Activity LED States.....	59
Table 19. I ² C Cable Connector Pinout.....	61
Table 20. Power Connector Pinout.....	61
Table 21. CPU to PCIe* NVMe* MCIO Connector Routing	65
Table 22. Intel® VROC for NVMe Activation License Key – Supported NVMe* RAID Features	67
Table 23. SATA_0 and SATA_1 Controller Feature Support.....	70
Table 24. Power / Sleep LED Functional States	73
Table 25. System Status LED State Definitions.....	74
Table 26. RJ45 Serial Port A Connector Pinout.....	77
Table 27. Supported Video Resolutions	78
Table 28. BMC Boot / Reset Status LED State Definition	82
Table 29. Processor Fault LED State Definition	82
Table 30. Memory Fault LED State Definition.....	83
Table 31. Fan Fault LED State Definition	84
Table 32. Thermal testing results interpretation for air-cooled systems	97
Table 33. Thermal Configuration Matrix with Dual 4 th Gen Processor Installed – Normal Operating Mode/Fan Fail mode (M50FCP1UR204).....	98
Table 34. Thermal Configuration Matrix with Dual 4 th Gen Processor Installed – Normal Operating Mode/Fan Fail mode (M50FCP1UR212).....	102
Table 35. Thermal Configuration Matrix with Dual 5 th Gen Processor Installed – Normal Operating Mode/Fan Fail mode (M50FCP1UR204).....	105
Table 36. Thermal Configuration Matrix with Dual 5 th Gen Processor Installed – Normal Operating Mode/Fan Fail mode (M50FCP1UR212).....	108

Table 37. Thermal Configuration Matrix with Single 4 th Gen Processor Installed – Normal Operating Mode/Fan Fail Mode (M50FCP1UR204).....	110
Table 38. Thermal Configuration Matrix with Single 4 th Gen Processor Installed – Normal Operating Mode/Fan Fail Mode (M50FCP1UR212).....	113
Table 39. Thermal Configuration Matrix with Single 5 th Gen Processor Installed – Normal Operating Mode/Fan Fail Mode (M50FCP1UR204).....	115
Table 40. Thermal Configuration Matrix with Single 5 th Gen Processor Installed – Normal Operating Mode/Fan Fail Mode (M50FCP1UR212).....	117
Table 41. SOV – Server Board Components.....	123
Table 42. SOV – System Board Components.....	123
Table 43. Server Chassis Components	123

1. Introduction

This technical product specification (TPS) describes the features, functions, architecture, and support specifications of the Intel® Server System M50FCP1UR.

The Intel® Server System M50FCP1UR is a purpose-built system that delivers power and performance at a peak efficiency in a 1U rack mount server form factor. It features the 4th & 5th Gen Intel® Xeon® Scalable processor family in a dual socket configuration, delivering high core count and new hardware-enhanced security features. Previous generations of the Intel® Xeon® processor and the Intel® Xeon® Scalable processor families are not supported.

For a complete overview of system features and functions, both this document and the Intel® Server Board M50FCP2SBSTD Technical Product Specification should be referenced.

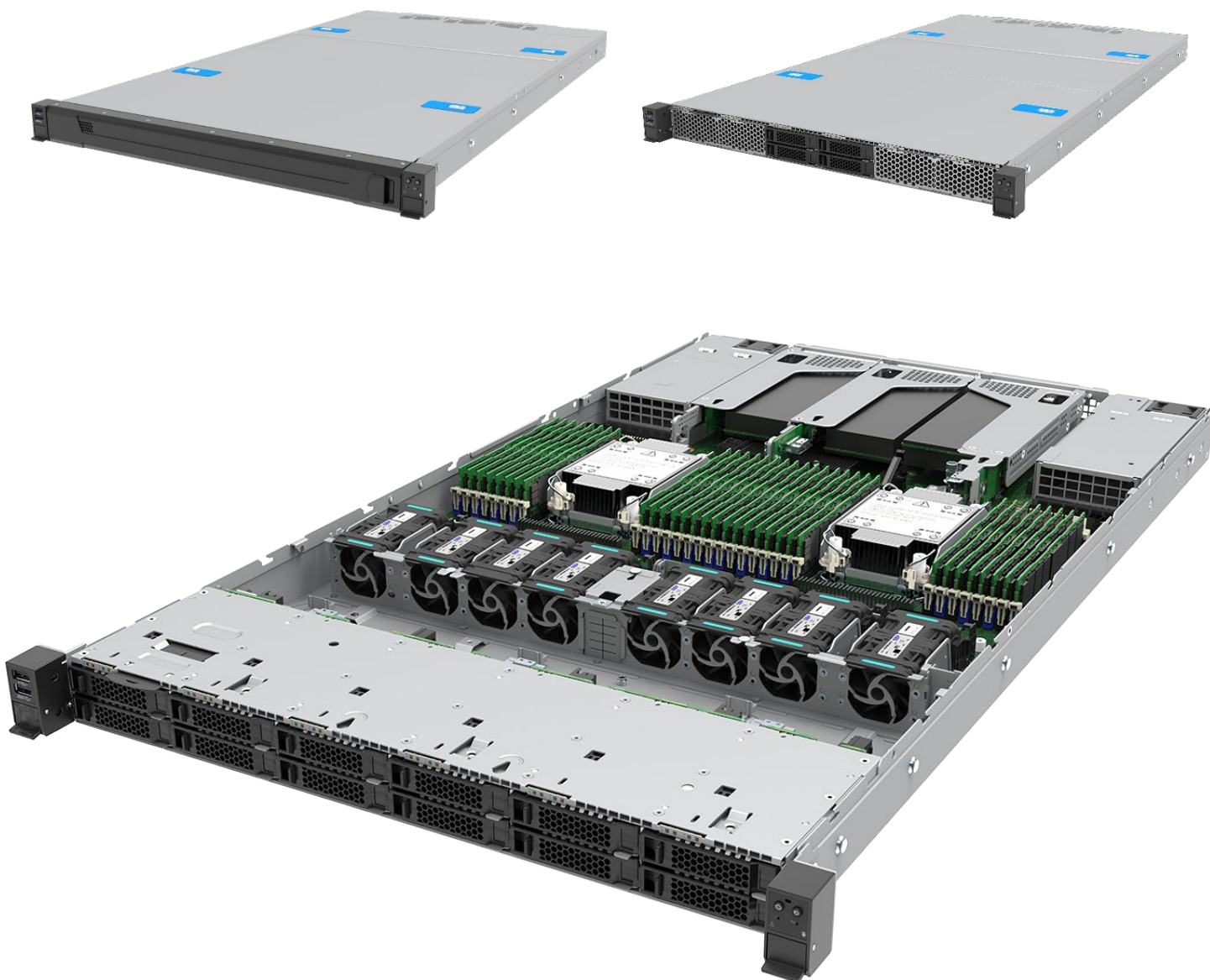

Figure 1. Intel® Server System M50FCP1UR

1.1 Reference Documents

For additional information and other support collaterals related to this Intel® server product, see Table 1. Listed documents and utilities can be downloaded from the following Intel websites or can be ordered through a local Intel support representative.

Note: Some of the Intel documents listed in Table 1. are classified as “Intel Confidential”. These documents are only made available under a nondisclosure agreement (NDA) with Intel. All Intel product documentation and support collaterals can be downloaded from Intel's Resource & Documentation Center website: <https://www.intel.com/content/www/us/en/documentation-resources/developer.html>.

For support 5th Gen Intel® Xeon® Scalable processor family, system board software stack needs to be in R01.02.0001 version or later. A System Update Package (SUP) with the latest system software stack can be downloaded from the following Intel website: <http://downloadcenter.intel.com>

Table 1. Intel® Server M50FCP Family Reference Documents and Support Collaterals

Topic	Document Title or Support Collateral	Document Classification
System integration instructions and service guidance	<i>Intel® Server System M50FCP2UR System Integration and Service Guide</i>	Public
System integration instructions and service guidance	<i>Intel® Server System M50FCP1UR System Integration and Service Guide</i>	Public
Technical system-level description	<i>Intel® Server System M50FCP2UR Technical Product Specification</i>	Public
Technical system-level description	<i>Intel® Server System M50FCP1UR Technical Product Specification</i>	Public
Technical board-level description	<i>Intel® Server Board M50FCP2SBSTD Technical Product Specification</i>	Public
Server configuration guidance and compatibility	<i>Intel® Server M50FCP Family Configuration Guide</i>	Public
Information on the Integrated BMC Web Console	<i>Integrated Baseboard Management Controller Web Console (Integrated BMC Web Console) User Guide</i>	Public
BIOS technical information on product family	<i>BIOS Firmware External Product Specification (EPS)</i>	Intel Confidential
BIOS setup information on product family	<i>BIOS Setup Utility User Guide</i>	Public
BMC technical information on product family	<i>Integrated Baseboard Management Controller Firmware External Product Specification (EPS)</i>	Intel Confidential
Base specifications for the IPMI architecture and interfaces	<i>Intelligent Platform Management Interface Specification Second Generation v2.0</i>	Intel Confidential
Specifications for the PCIe* 3.0 architecture and interfaces	<i>PCIe Base Specification, Revision 3.0</i>	Public
Specifications for the PCIe* 4.0 architecture and interfaces	<i>PCIe Base Specification, Revision 4.0</i>	Public
Specifications for the PCIe* 5.0 architecture and interfaces	<i>PCIe Base Specification, Revision 5.0</i>	Public
Specification for OCP*	<i>Open Compute Project (OCP) 3.0 Specification</i>	Intel Confidential
Specifications of Trust Domain Extensions (Depends on 5 th Gen processor)	<i>Intel® Trust Domain Extensions (Intel® TDX) White Paper</i>	Public

Intel® Server System M50FCP1UR Technical Product Specification

Topic	Document Title or Support Collateral	Document Classification
TPM for PC Client specifications	<i>TPM PC Client Specifications, Revision 2.0</i>	Intel Confidential
Functional specifications of 4 th Gen Intel® Xeon® Scalable processor family	<i>Sapphire Rapids External Design Specification (EDS)</i> : Document IDs: 630161, 612246, 612172, 633350, 611488	Intel Confidential
Processor thermal design specifications and recommendations	<i>Sapphire Rapids Thermal and Mechanical Specifications and Design Guide (TMSDG)</i> : Document ID: 609847	Intel Confidential
Specifications of 5 th Gen Intel® Xeon® Scalable processor family	<i>Emerald Rapids External Design Specification(EDS)</i> : Document IDs: 721175, 723370	Intel Confidential
BIOS and BMC security best practices	<i>Intel® Server Systems Baseboard Management Controller (BMC) and BIOS Security Best Practices White Paper</i>	Public
Managing an Intel server overview	<i>Managing an Intel Server System 2020</i>	Public
Latest system software updates: BIOS and firmware	<i>Intel® System Update Package (SUP) for Intel® Server M50FCP Family</i>	Public
	<i>Intel® Server Firmware Update Utility - Various operating system support</i>	
	<i>Intel® Server Firmware Update Utility User Guide</i>	
To obtain full system information	<i>Intel® Server Information Retrieval Utility - Various operating system support</i>	Public
	<i>Intel® Server Information Retrieval Utility User Guide</i>	
To configure, save, and restore various system options	<i>Intel® Server Configuration Utility - Various operating system support</i>	Public
	<i>Intel® Server Configuration Utility User Guide</i>	
Product Warranty Information	<i>Warranty Terms and Conditions</i>	Public
Intel® Data Center Manager (Intel® DCM) information	<i>Intel® Data Center Manager (Intel® DCM) Product Brief</i>	Public
	<i>Intel® Data Center Manager (Intel® DCM) Console User Guide</i>	Public

Note: Intel Confidential documents are made available under a nondisclosure agreement (NDA) with Intel and must be ordered through your local Intel representative.

2. Server System Overview

This chapter provides a general overview of the Intel® Server System M50FCP1UR. More in depth information can be found in subsequent chapters. Additional server board specific information can be found by referencing the Intel® Server Board M50FCP2SBSTD Technical Product Specification.

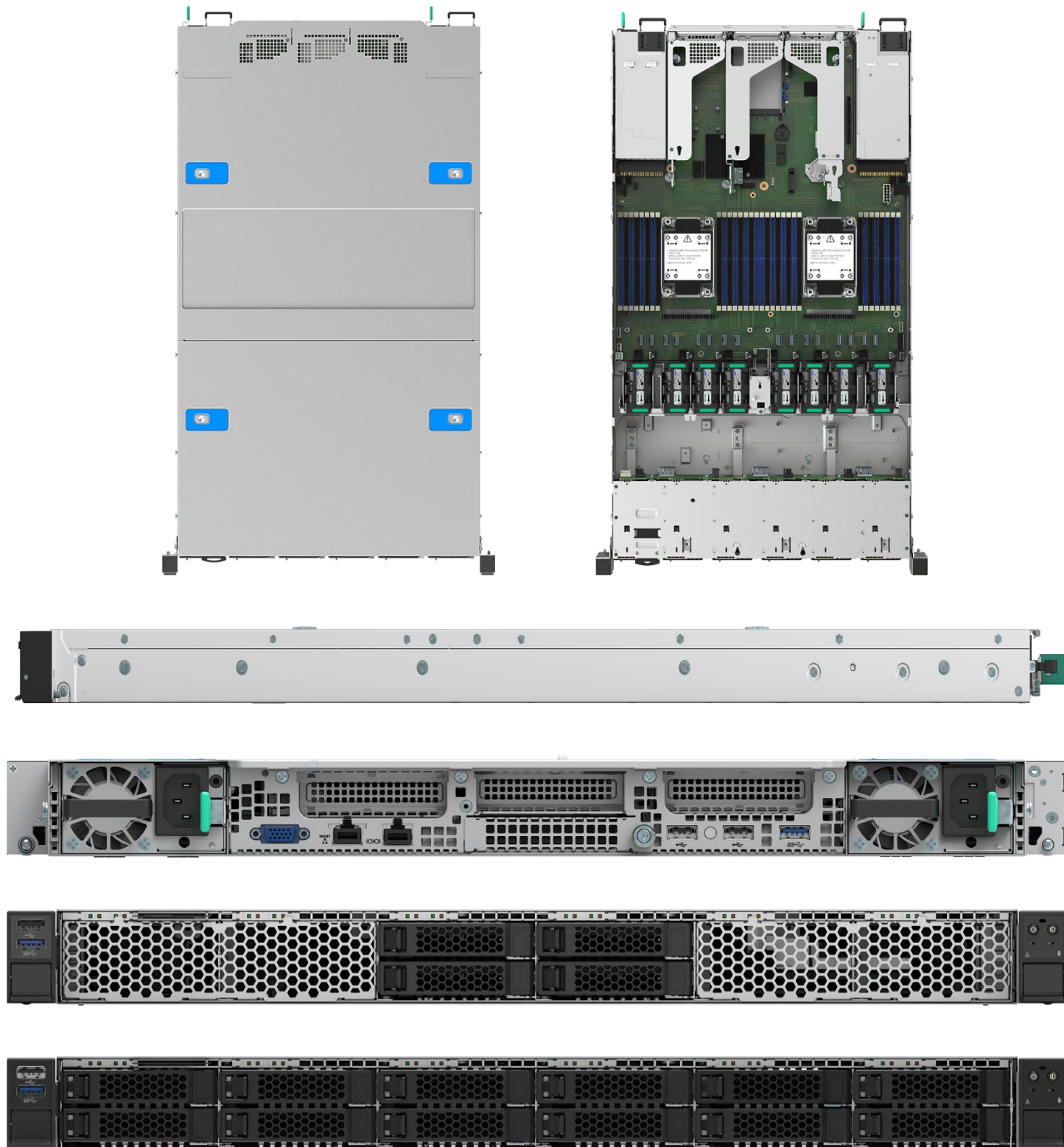

Figure 2. Intel® Server System M50FCP1UR System Views

2.1 Server System Feature Set

The following table provides a high-level overview of the features and available options supported by the Intel® Server System M50FCP1UR.

Table 2. Intel® Server System M50FCP1UR Features

Feature	Details
Chassis Type	1U rack mount chassis
Chassis Dimensions	767x 438.5 x 43 mm (L x W x H)
Server Board	Intel® Server Board M50FCP2SBSTD
Processor Support	<ul style="list-style-type: none"> • Dual Socket-E LGA4677 • Supported 4th & 5th Gen Intel® Xeon® Scalable processor family SKUs: <ul style="list-style-type: none"> ○ Intel® Xeon® Platinum 84xxx/85xxxx processor ○ Intel® Xeon® Gold 64xxx/65xxxx processor ○ Intel® Xeon® Gold 54xxx/55xxxx processor ○ Intel® Xeon® Silver44xxx/45xxxx processor ○ Intel® Xeon® Bronze 34xxx/35xxxx processor • Intel® UPI links: 3 at 16 GT/s (4th Gen Intel® Xeon® Platinum and Gold families) or 2 at 16 GT/s (Silver family) • Intel® UPI links: 3 at 20 GT/s (5th Gen Intel® Xeon® Platinum and Gold families) or 2 at 16 GT/s (Silver family) • Intel® Xeon® Bronze processors are used in single processor configurations only. <p>Note: Previous generation Intel® Xeon® processor and Intel® Xeon® Scalable processor families are not supported.</p> <p>Note: For processor support details, see the <i>Intel® Server Board M50FCP2SBSTD Technical Product Specification</i>.</p>
Maximum Processor Thermal Design Power (TDP)	<ul style="list-style-type: none"> • up to 350W – Intel® Server System M50FCP1UR204 – 4x2.5" Drive Configurations • up to 205W – Intel® Server System M50FCP1UR212 – 12x2.5" Drive Configurations <p>Note: The maximum supported processor TDP is dependent on the specific system configuration.</p>
Chipset	<ul style="list-style-type: none"> • Intel® C741 chipset platform controller hub (PCH) • Embedded features enabled on this server board: <ul style="list-style-type: none"> ○ SATA 3.0 support ○ USB 3.0 support ○ PCIe 3.0 support
Memory Support	<ul style="list-style-type: none"> • 32 memory slots: <ul style="list-style-type: none"> ○ 16 memory slots per processor, eight memory channels per processor ○ Two memory modules per channel • Registered DDR5 DIMM (standard RDIMM, 3DS-RDIMM, and 9x4 RDIMM) Note: 3DS = 3-dimensional stacking. • All DDR5 DIMMs must support ECC • Memory capacity: <ul style="list-style-type: none"> ○ Up to 4 TB per processor (processor SKU dependent) using DDR5 DIMMs • Memory data transfer rates <ul style="list-style-type: none"> ○ Up to 5600 MT/s at one DIMM per channel (Supported on 5th Gen Intel® Xeon® Scalable processor) ○ Up to 4400 MT/s at two DIMMs per channel (processor SKU dependent) • DDR5 standard voltage of 1.1 V <p>Note: For memory support details, see the <i>Intel® Server Board M50FCP2SBSTD Technical Product Specification</i>. Pending validation results for DDR5 DIMM size 256GB.</p>
System Fan Support	<ul style="list-style-type: none"> • Eight managed 40-mm hot swap capable system fans • Integrated fans included with each installed power supply module <p>Note: System fan redundancy may only be supported on specific system configurations.</p>
Power Supply Options	<ul style="list-style-type: none"> • The server system can support one or two power supply modules configurations.

Feature	Details
Power Supply Options (cont.)	<ul style="list-style-type: none"> • Depending on the power supply configuration, the system will support the following power operating modes: <ul style="list-style-type: none"> ○ 1+0 – Single functional power supply ○ 1+1 – redundant power ○ 2+0 – combined power, no redundancy • Power supply options: <ul style="list-style-type: none"> ○ AC 1,300 W Titanium ○ AC 1,600 W Titanium
Server Board Network Support	See optional Open Compute Project (OCP) adapter support.
Open Compute Project* (OCP*) Adapter Support	<ul style="list-style-type: none"> • Server board x16 PCIe 5.0 OCP 3.0 connector (Small Form-Factor) slot. Refer to https://servertools.intel.com/sct for the latest list of adapters supported by the server board.
Riser Card Support	<p>Concurrent support for up to four riser cards, including one PCIe Interposer riser card, with support for up to three PCIe add-in cards. In the following description HL = Half Length, LP = Low Profile.</p> <p>Riser Slot #1</p> <ul style="list-style-type: none"> • Riser Slot #1 supports x16 PCIe lanes routed from CPU 0 • PCIe 5.0 support for up to 32 GB/s <p>Riser Slot #1 supports the following Intel riser card option:</p> <ul style="list-style-type: none"> • PCIe slot riser card (iPC FCP1URISER1), which supports: <ul style="list-style-type: none"> ○ One single-width slot (x16 electrical, x16 mechanical) <p>Riser Slot #2</p> <ul style="list-style-type: none"> • Riser Slot #2 supports X24 PCIe lanes routed from CPU 1 • PCIe 5.0 support for up to 32 GB/s <p>Riser Slot #2 supports the following Intel riser card options:</p> <ul style="list-style-type: none"> • PCIe slot riser card (iPC FCP1URISER2), which supports: <ul style="list-style-type: none"> ○ One LP/HL, single-width slot (x16 electrical, x16 mechanical) • Riser card (iPC FCP1URISER2KIT), which supports: <ul style="list-style-type: none"> ○ One LP/HL, single-width slot (x16 electrical, x16 mechanical) ○ One x8 PCIe MCIO connector with retimer <p>PCIe* Interposer Riser Slot (requires PCIe* Riser Card in Riser Slot #2)</p> <ul style="list-style-type: none"> • PCIe interposer riser slot, which supports the PCIe interposer riser card as an accessory option. • This card supports one PCIe add-in card (x8 electrical, x8 mechanical). • The PCIe interposer riser card can be used only when it is connected to the PCIe riser card in Riser Slot #2. The interposer riser card uses x8 PCIe data lanes routed from the PCIe MCIO connector on the PCIe riser card. • The Intel accessory kit (iPC FCP1URISER2KIT) includes the PCIe interposer riser card, PCIe riser card, and PCIe interposer cable. <p>Riser Slot #3</p> <ul style="list-style-type: none"> • Not supported in 1U System.
PCIe* NVMe* Support	<ul style="list-style-type: none"> • 16 server board mounted PCIe MCIO connectors, eight per processor (up to 12 used in 1U) • Additional NVMe support through select riser card options (See Riser Card Support) • Two M.2 NVMe/SATA connectors • Intel® Volume Management Device 3.0 (Intel® VMD 3.0) support • Intel® Virtual RAID on CPU for NVMe (Intel® VROC NVMe) 8.0 <ul style="list-style-type: none"> ○ Requires installation of an Intel® VROC for NVMe License Activation Key accessory option. This accessory option is a software key that enables RAID support for NVMe SSDs interfaced through the onboard PCIe MCIO connectors. Depending on the option installed, RAID levels supported are 0,1,10 or 0,1,5,10.
Video Support	<ul style="list-style-type: none"> • Integrated 2D video controller • 128 MB of DDR4 video memory • One VGA connector on the rear of the chassis.

Feature	Details
Server Board SATA Support	<ul style="list-style-type: none"> • 10 x SATA III ports (6 Gb/s, 3 Gb/s, and 1.5 Gb/s transfer rates supported) <ul style="list-style-type: none"> ○ Two M.2 connectors: SATA / PCIe ○ Two 4-port Mini-SAS HD (SFF-8643) connectors • Intel® Virtual RAID on CPU for SATA (Intel® VROC for SATA) 8.0 <ul style="list-style-type: none"> ○ Support for RAID levels 0,1,5,10 (Standard feature, no additional upgrade key required)
USB Support	<ul style="list-style-type: none"> • One USB 3.0 and two USB 2.0 connectors on the rear of the chassis • One USB 3.0 and one USB 2.0 connector on the front panel
Serial Support	One external RJ-45 Serial Port A connector on the rear of the chassis
Front Drive Bay Options	<ul style="list-style-type: none"> • 4 x 2.5" SAS/SATA/NVMe hot swap drive bays (iPC – M50FCP1UR204) • 12 x 2.5" SAS/SATA/NVMe hot swap drive bays (iPC M50FCP1UR212)
Server Management	<ul style="list-style-type: none"> • Integrated Baseboard Management Controller (BMC) • One dedicated RJ45 1 GbE server management port • Intelligent Platform Management Interface (IPMI) 2.0 compliant • Redfish* compliant • Support for Intel® Data Center Manager (Intel® DCM) • Support for Intel® Server Debug and Provisioning Tool (Intel® SDP Tool) • Integrated BMC Web Console • Intel® Light-Guided Diagnostics • Optional Advanced Server Management features (Purchased separately)
Server Management Processor (SMP)	<ul style="list-style-type: none"> • Aspeed* AST2600 Remote Management Server Processor • Embedded features enabled on this server board: <ul style="list-style-type: none"> • Baseboard management controller (BMC) • 2D video graphics adapter
System Configuration and Recovery Jumpers	<ul style="list-style-type: none"> • BIOS load defaults • BIOS password clear • Intel® Management Engine (Intel® ME) firmware force update • BIOS_SVN downgrade • BMC_SVN downgrade
Security Features	<ul style="list-style-type: none"> • Intel® Platform Firmware Resilience (Intel® PFR) technology with an I2C interface • Intel® Software Guard Extensions (Intel® SGX) • Converged Intel® Boot Guard and Intel® Trusted Execution Technology (Intel® TXT) • Intel® Total Memory Encryption – Multi-Key (Intel® TME-MK) • Trusted platform module 2.0 (China version): iPC AXXTPMCHNE8 (accessory option) • Trusted platform module 2.0 (rest of the world): iPC AXXTPMENC9 (accessory option) • Intel® Trust Domain Extension (Intel® TDX) (Supported on 5th Gen Intel® Xeon® Scalable processor)
Supported Rack Mount Kit Accessory Options	<ul style="list-style-type: none"> • CYPHALFEXTRAIL – Value rack mount rail kit • CYPFULLEXTRAIL – Premium rail kit with cable management arm (CMA) support • AXXCMA2 – Cable management arm (supports CYPFULLEXTRAIL only)
BIOS	Unified Extensible Firmware Interface (UEFI)-based BIOS (legacy boot not supported)
Environment Limits	<ul style="list-style-type: none"> • Operating temperature: 10 °C – 35 °C (50 °F – 95 °F) • Non-operating temperature: -40 °C – 70 °C (-40 °F – 158 °F)

2.2 System Feature Identification

This section provides system views and identifies key system features for all supported system configurations of the Intel® Server System M50FCP1UR.

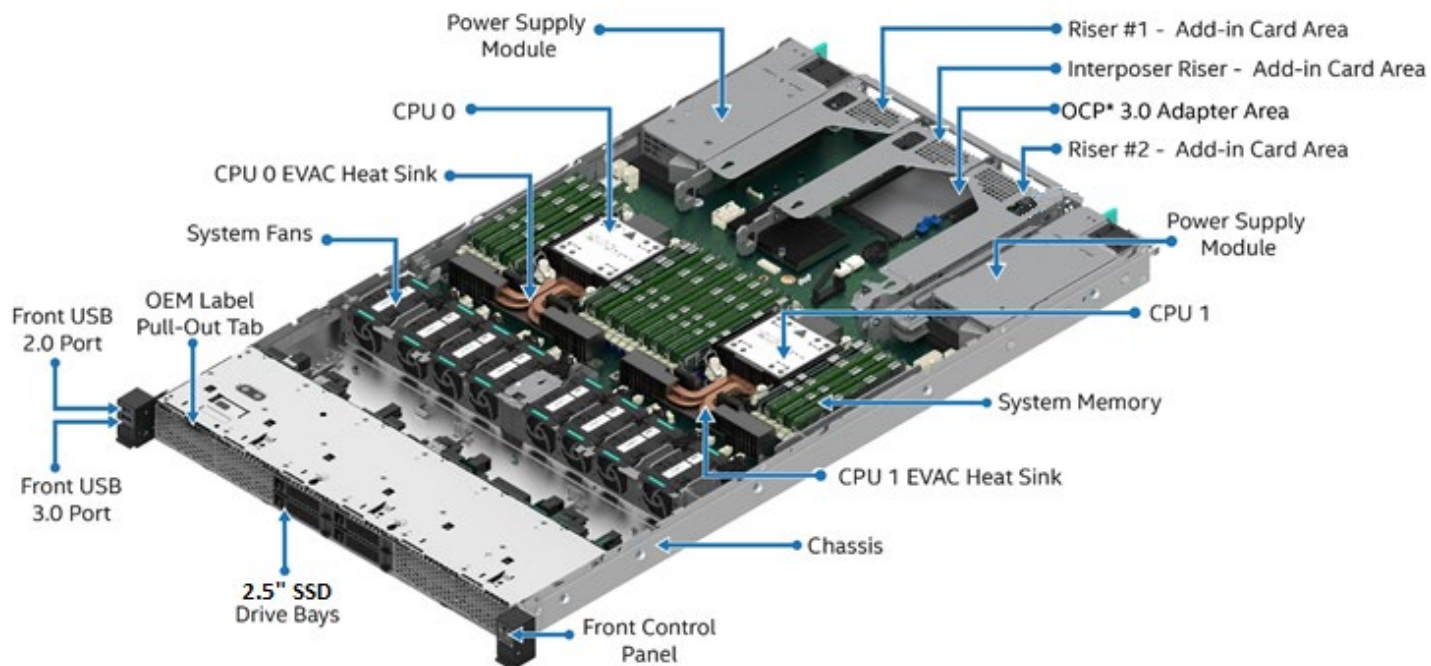
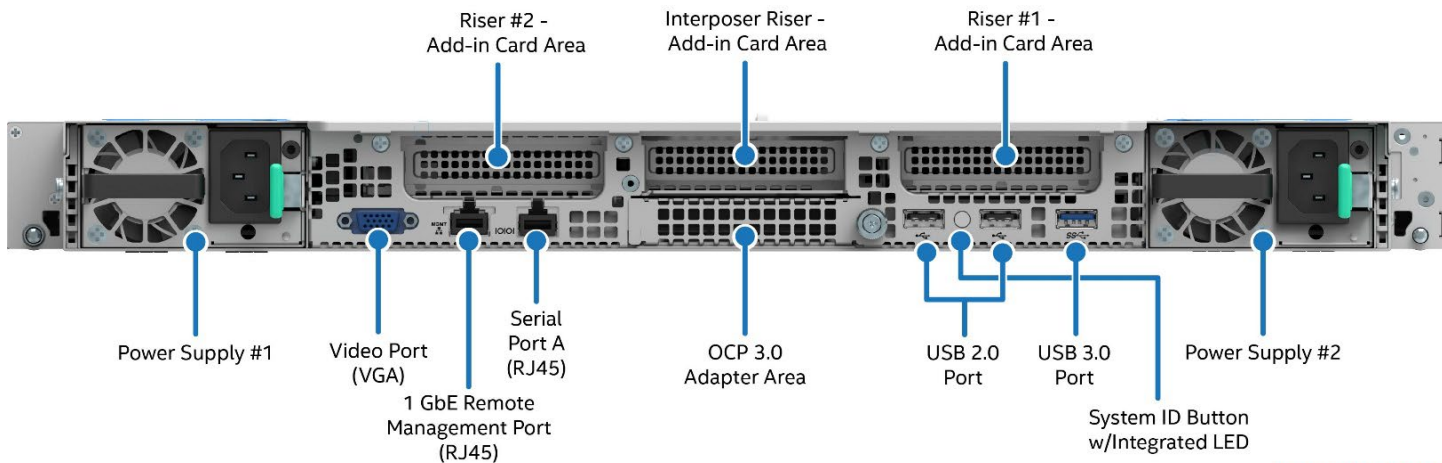

Figure 3. Server System Components Overview



Ref #: FCP20013

Figure 4. Back Panel Feature Identification



4 x 2.5" Drive Bay Configuration



12 x 2.5" Drive Bay Configuration

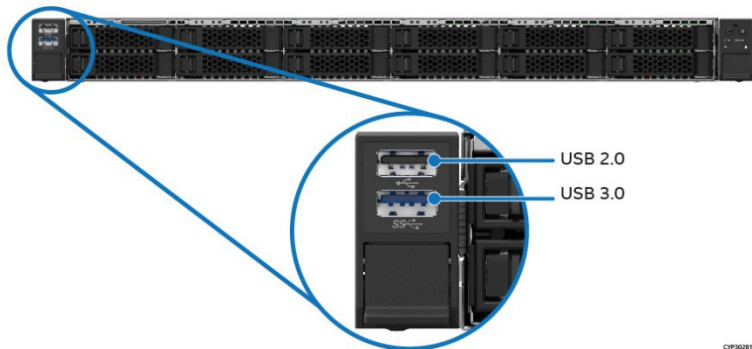

Front USB Ports



Front Control Panel

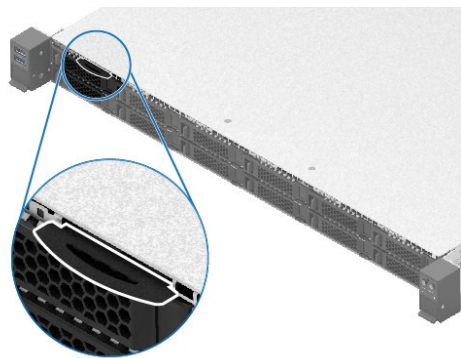

Front Pull-out Tab

Figure 5. Front Panel Feature Identification



Figure 6. System with Optional Front Bezel

2.3 Server Board Features

The architecture of the Intel® Server Board M50FCP2SBSTD was developed around the integrated features and functions of the 4th & 5th Gen Intel® Xeon® Scalable processor family, Intel® C741 chipset PCH, and Aspeed AST2600* Server Management Processor (SMP).

Figure 7 provides an overview of the server system architecture, showing the features and interconnects of the major subsystem components.

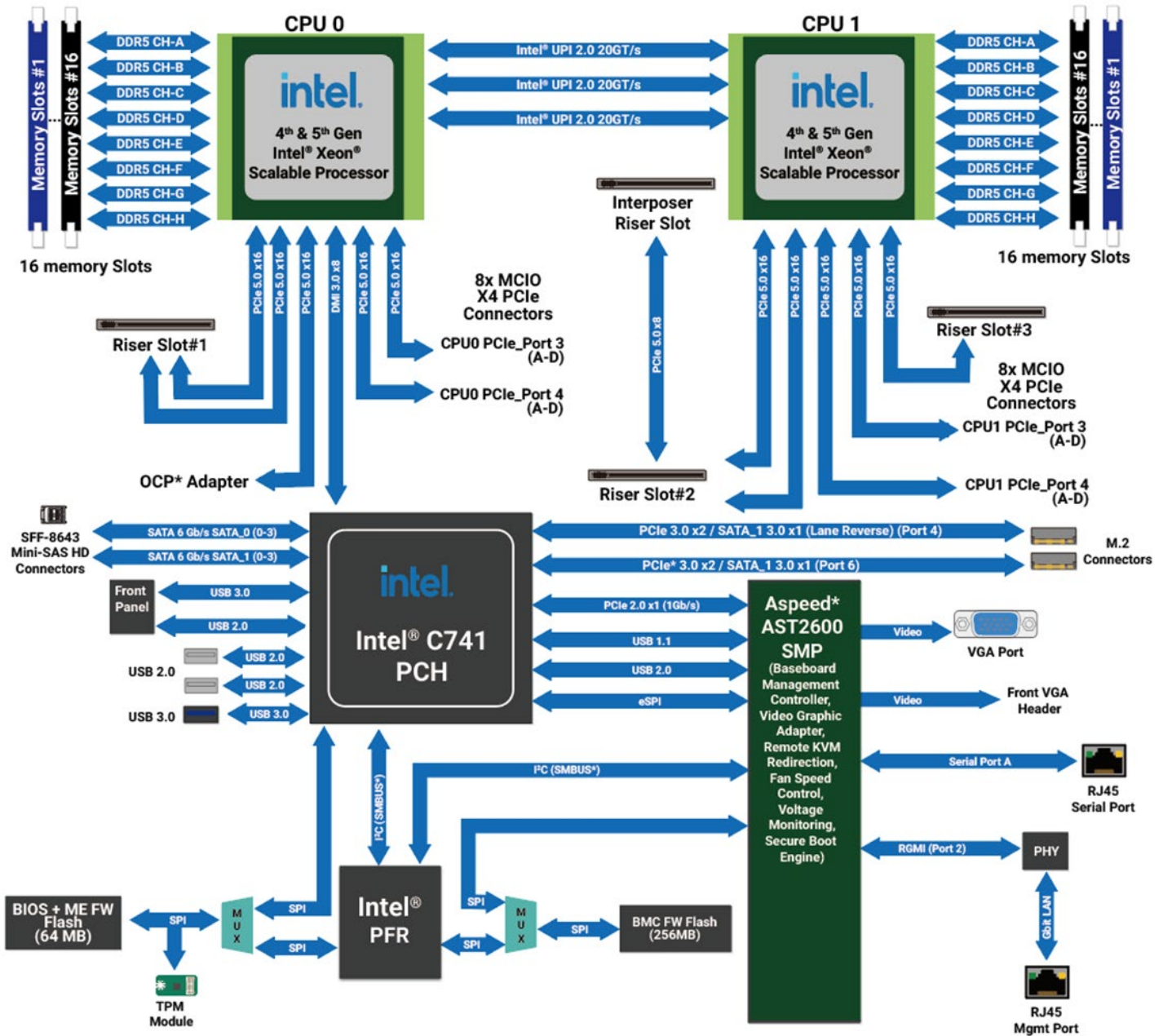
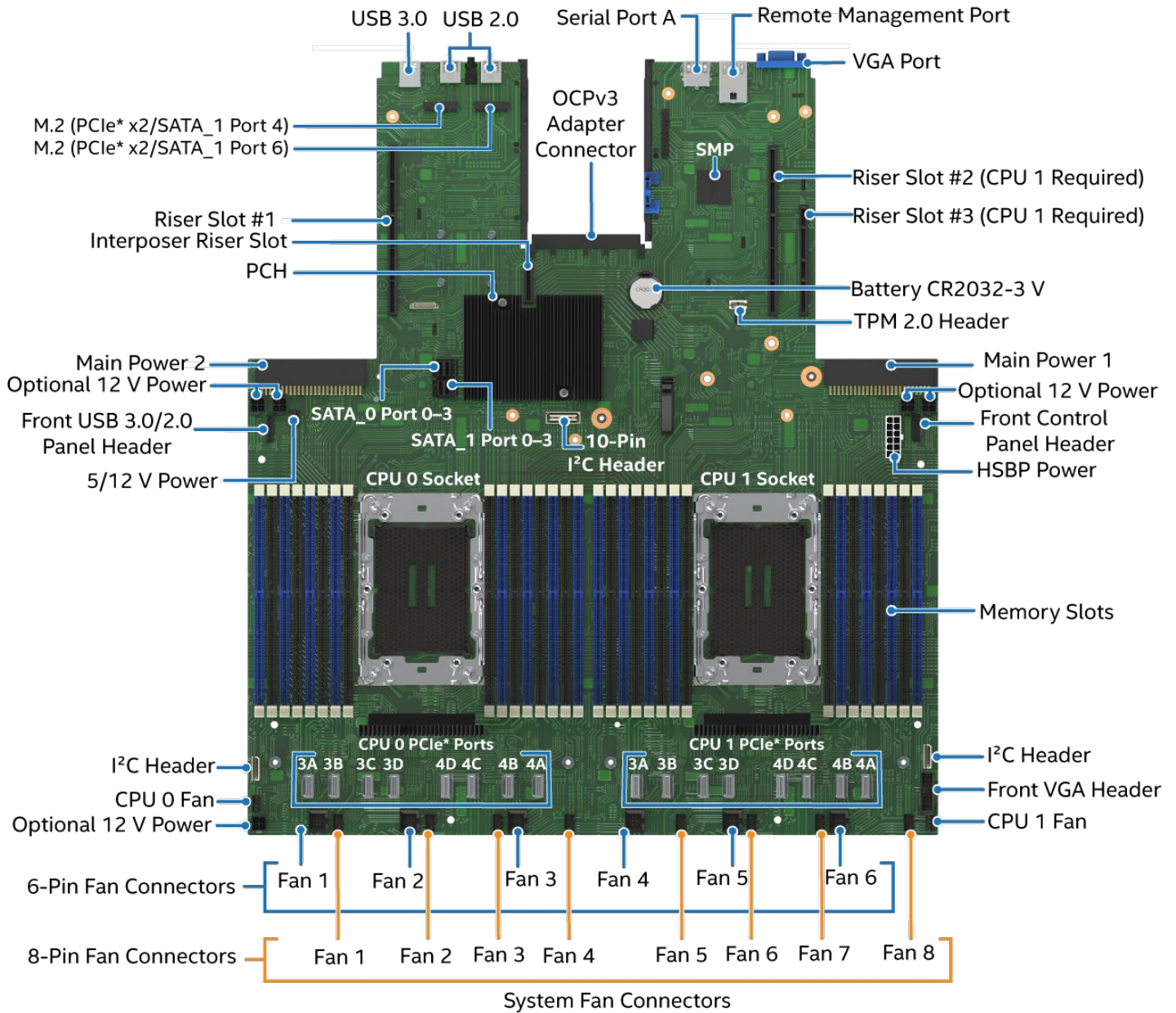

Figure 7. Intel® Server Board M50FCP2SBSTD Architectural Block Diagram

Figure 8 provides a general overview of the physical server board, identifying key feature and component locations.



Ref #: FCP10245

Figure 8. Intel® Server Board M50FCP2SBSTD Component / Feature Identification

The server board includes LEDs to identify system status and/or indicate a component fault. The following two figures identify Intel® Light-Guided Diagnostic LEDs on the server board. For more information on Intel® Light-Guided Diagnostics, see Chapter 8.

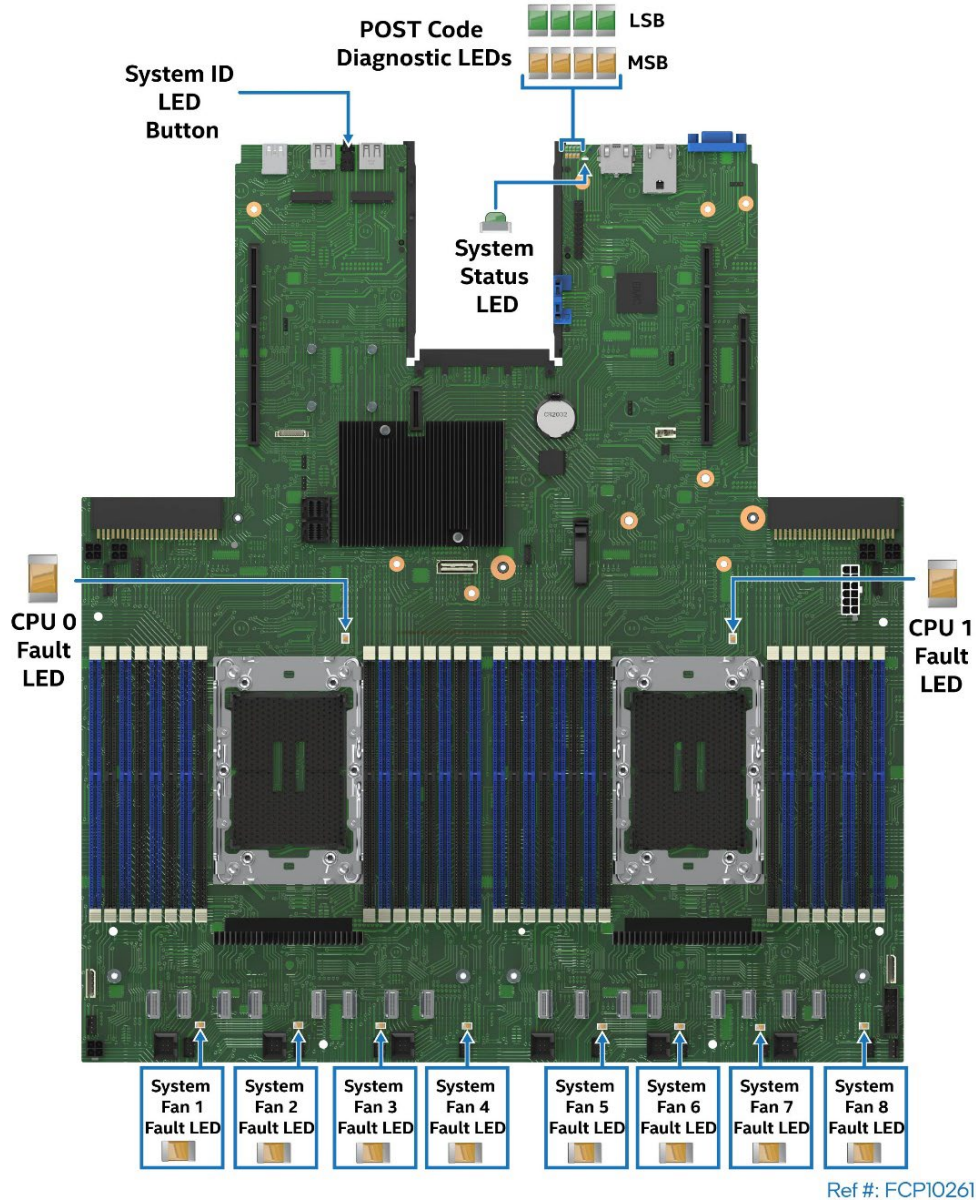

Ref #: FCP10261

Figure 9. Intel® Light-Guided Diagnostics – LED Identification

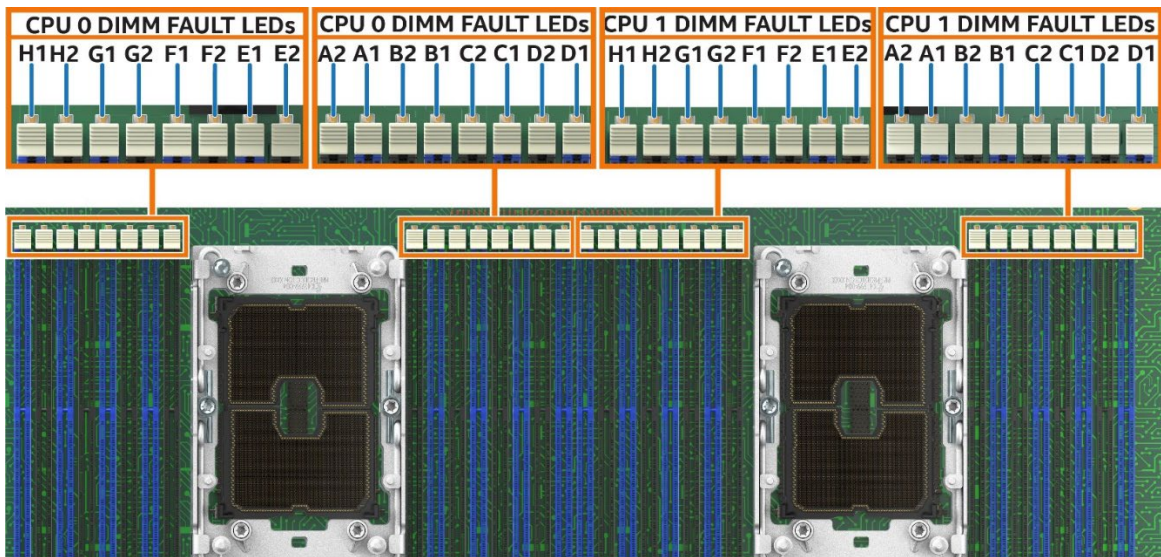

Ref #: FCP10170

Figure 10. Intel® Light-Guided Diagnostics – Memory Fault LEDs

The server board includes several jumper blocks (see [Figure 11](#)) that are used to configure, protect, or recover specific features of the server board. For more information about the jumpers, see the *Intel® Server Board M50FCP2SBSTD Technical Product Specification (TPS)*.

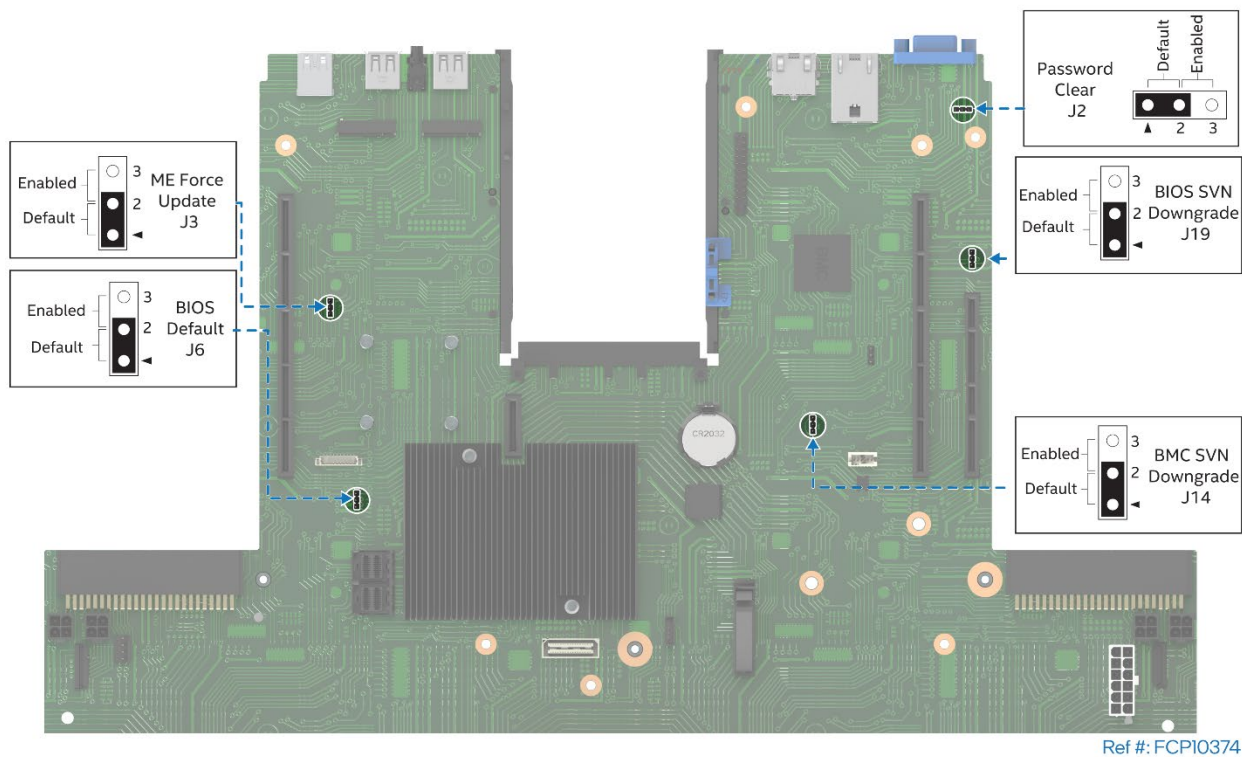
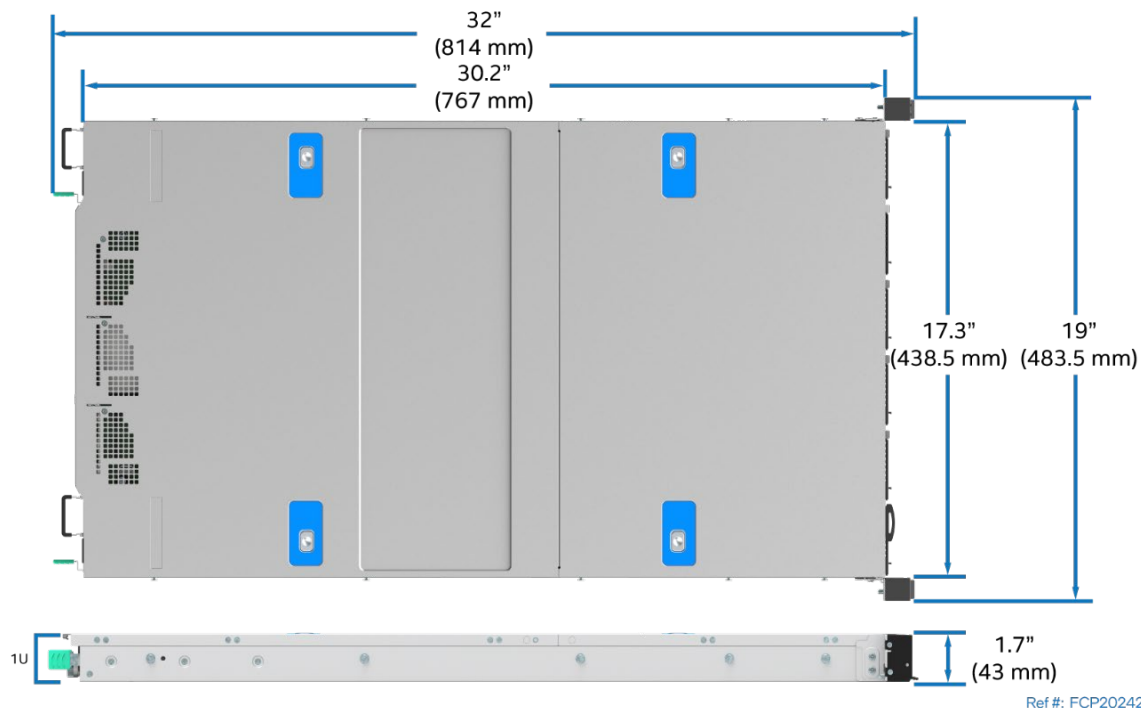

Figure 11. System Configuration and Recovery Jumpers

2.4 System Dimensions and Labeling Options

The following subsections provide chassis dimensional data for all supported system configurations.



Ref #: FCP20242

Figure 12. System Dimensions

The chassis includes an embossed system label location a top cover panel. A label that is placed within the emboss area is protected from being scratched as the system slides in or out of a system rack.

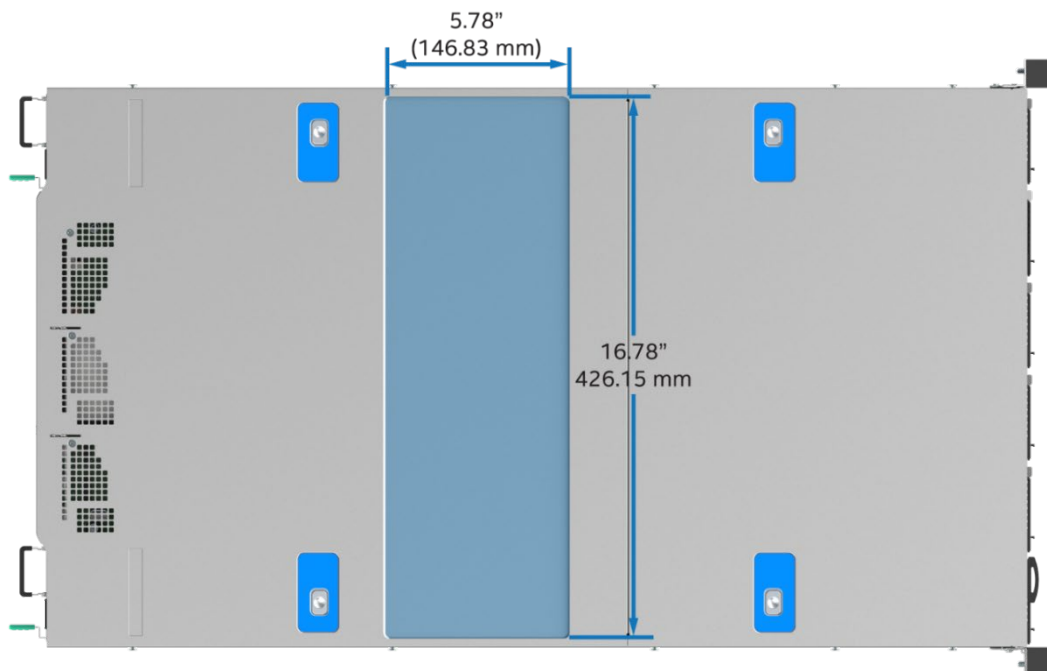

Ref #: FCP20261

Figure 13. Label Emboss Dimensions

An additional system label can be placed on a mylar pull-out tab that extends out approximately 61 mm from the chassis front. The pull-out tab can be useful to obtain system information while the system is installed within a system rack.

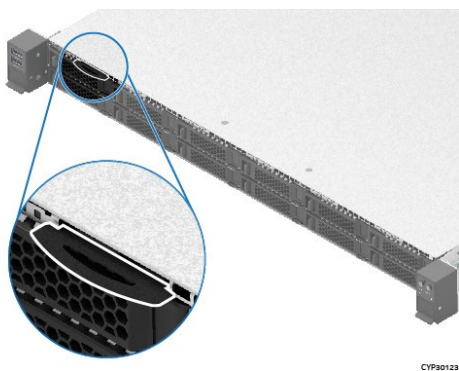

Figure 14. Pull-out Tab Location

The following figure shows the pull-out tab label emboss dimensions.

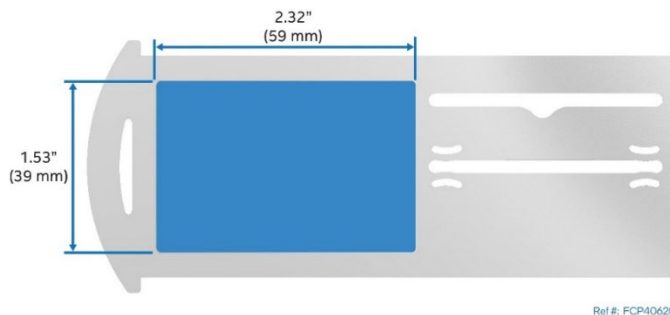

Figure 15. Pull-out Tab Label Emboss Dimensions

2.5 System Top Cover

The system top cover consists of two panels: one over the front half of the system and one over the back half of the system. To maintain system thermals, both top cover panels must be installed when the system is operational. Removal of one or both top cover panels is necessary when installing or replacing any system component integrated within the server chassis.

The top cover panels support the option of securing them to the chassis using a set of four screws as shown in [Figure 16](#).



Figure 16. System Top Cover Shipping Screws

If present, remove the four screws before attempting to remove the top panel covers from the system.

Shipping Note: When transporting the server system, Intel recommends installing the four top cover screws before shipping.

Each top cover panel includes a set of two latches to lock them in place.

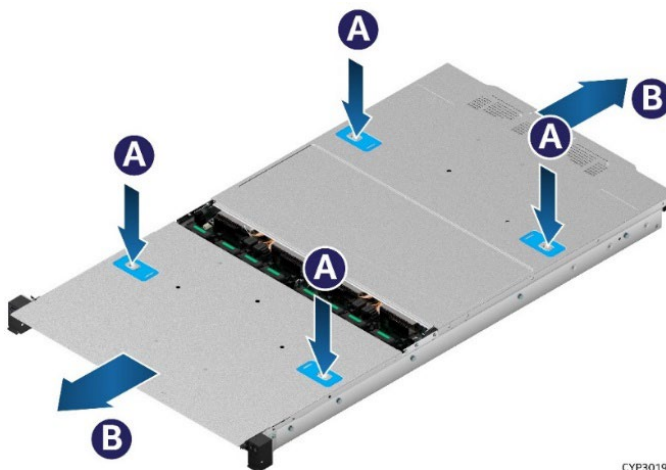

Figure 17. System Top Cover Removal

To remove a top cover panel, push down on both the left and right latch buttons of the given top panel (see letter A), and slide the top cover panel towards the front (front panel) or back (back panel) of the chassis (see Letter B).

When installing a top cover panel, align and set the top cover panel on the chassis (see Letter A in the following figure), and slide it inwards until it locks in place.

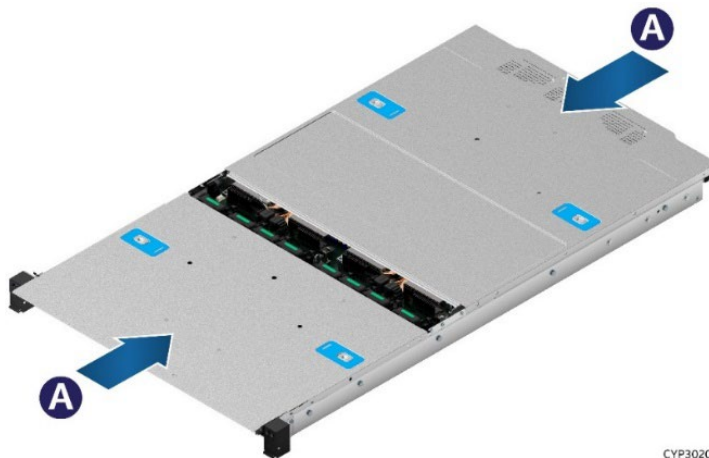

Figure 18. System Top Cover Installation

For more information, see the *Intel® Server System M50FCP1UR System Integration and Service Guide*.

2.6 System Cable Routing Channels

All internal cables routed between the back and the front of the system must be routed using the cable channel located between the right air baffle and the right chassis sidewall (See [Figure 19](#)).

Cables connected between the onboard PCIe MCIO connectors and the backplane behind the front drive bay are routed using the cable channel located between system fans 4 and 5.

No cables should be routed between the left chassis sidewall and left air baffle, or between the memory modules and processors

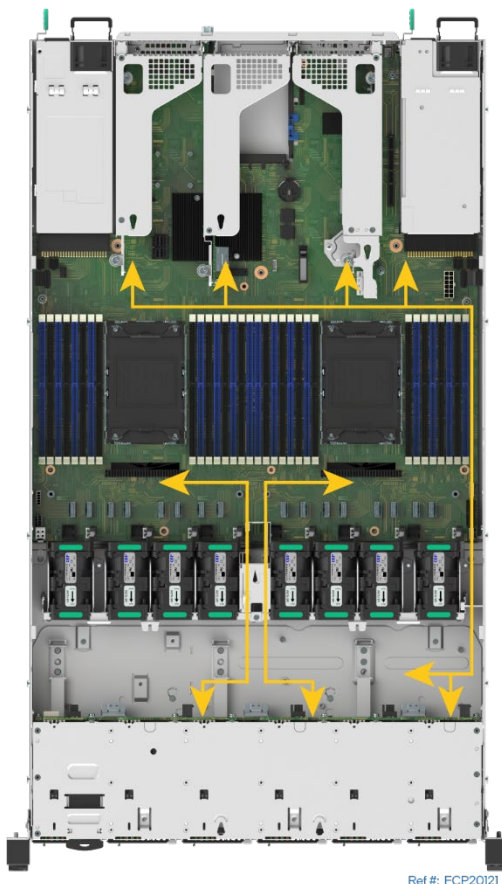
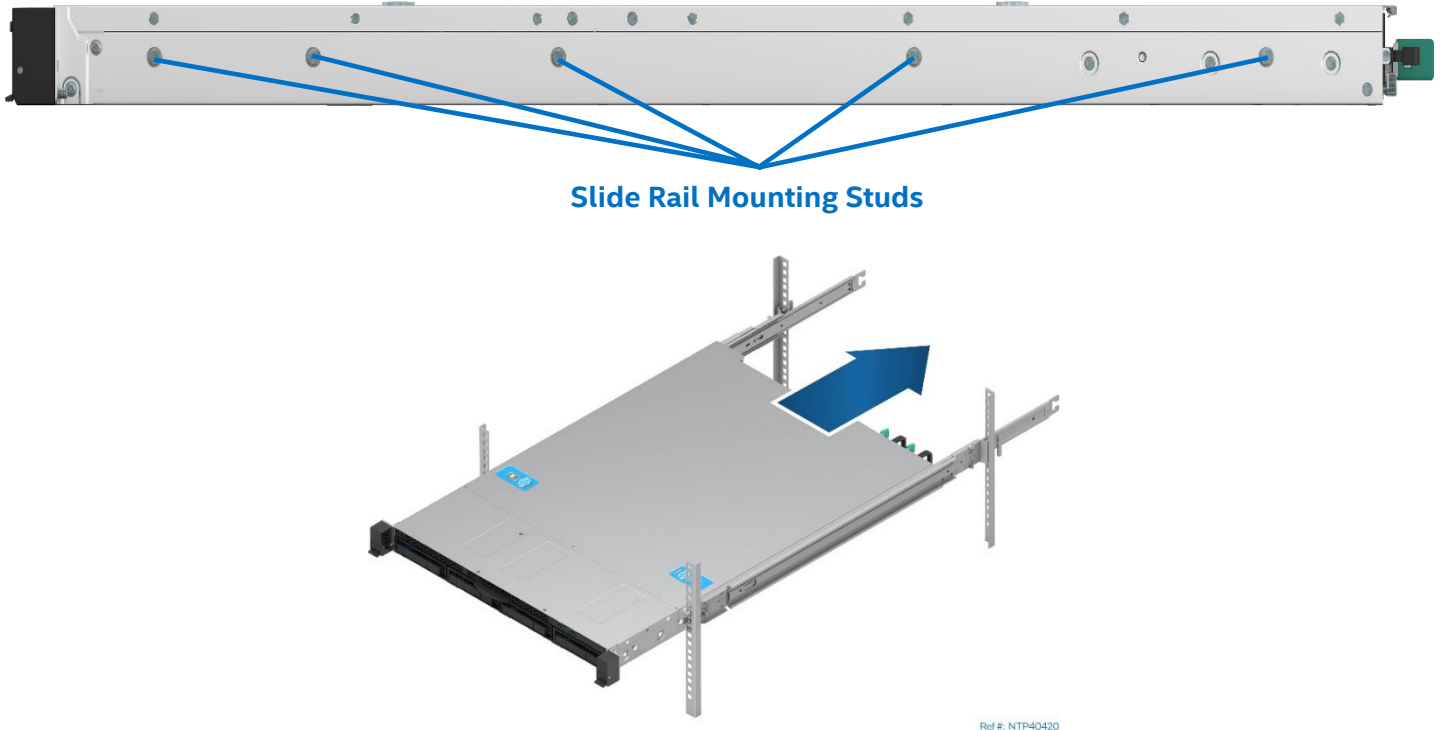

Figure 19. System Cable Routing Channels

2.7 Available Rack and Cabinet Mounting Kit Options

The Intel® Server System M50FCP1UR is a 1U rack mount server system that requires a rail kit to install it within a 4-post server rack or cabinet. Rails are attached to the server by placing them over and sliding them onto a set of mounting studs located on each side of the server chassis.



- **CYPHALFEXTRAIL** – Value Rack Mount Rail Kit
 - 1U, 2U compatible
 - Tool-less chassis attachment
 - Tools required to attach rails to rack
 - Rack installation front and rear post distance adjustment 660-838 mm
 - 560 mm travel distance
 - Half extension from rack
 - 31 kg (68.34 lbs.) maximum support weight
 - No support for Cable Management Arm
- **CYPFULLEXTRAIL** – Premium Rail Kit with cable management arm (CMA) support
 - 1U, 2U compatible
 - Tool-less chassis attachment
 - Tool-less installation to rack
 - Rack installation front and rear post distance adjustment from 623mm ~ 942mm
 - 820 mm travel distance
 - Full extension from rack
 - 31 Kgs (68.34 lbs.) maximum supported weight
 - Support for Cable Management Arm AXXCMA2
- **AXXCMA2** – Cable Management Arm (supports **CYPFULLEXTRAIL** only)

Caution: Exceeding the specified maximum weight limit of a given rail kit or misalignment of the server in the rack may result in failure of the rack rails, damaging the system, or causing personal injury. Using two people or the use of a mechanical assist tool to install and align the server into the rack is highly recommended.

Shipping Disclaimer: Available rack and cabinet mounting kits are not designed to support shipment of the server system while installed in a rack or cabinet. If choosing to do so, Intel strongly recommends that appropriate shock and vibration testing of the full rack configuration be performed before shipment.

Intel does not perform testing that exposes the racked system to the stresses of a transport environment using the complex combination of third-party racks, cabinets, and custom packaging options.

When transporting a fully integrated system, Intel highly recommends that the system have four shipping screws (not included) installed to the system back panel (see [Figure 20](#)). These screws provide the chassis with additional support by reducing possible chassis flex and minimizing possible sag of the base plate. Installed screws should meet the following specifications: flat head, 6–32 thread, 3.75 mm length.



Ref #: FCP20090

Figure 20. Rear Panel Shipping Screw Holes

2.8 System Level Environmental Limits

The following table lists the system level operating and non-operating environmental limits.

Table 3. System Environmental Limits Summary

Parameter		Limits			
Temperature	Operating	ASHRAE Class A2: Continuous Operation. 10–35 °C (50–95 °F) with the maximum rate of change not to exceed 10 °C per hour. ¹ ASHRAE Class A3: Includes operation up to 40 °C for up to 900 hrs. per year. ¹ ASHRAE Class A4: Includes operation up to 45 °C for up to 90 hrs. per year. ¹			
	Non-Operating	-40 through 70 °C (-40 through 158 °F)			
Altitude	Operating	Support operation up to 3,050 m (10,006 feet) with ASHRAE class de-ratings.			
Humidity	Shipping	50% to 90%, non-condensing with a maximum wet bulb of 28 °C (at temperatures 25–35 °C)			
Shock	Operating	Half sine, 2 g, 11 msec			
	Unpackaged	Trapezoidal, 25 g, velocity change is based on packaged weight			
	Packaged	ISTA (International Safe Transit Association) Test Procedure 3A 2008			
Vibration	Unpackaged	5–500 Hz, 2.20 g RMS random			
	Packaged	ISTA (International Safe Transit Association) Test Procedure 3A 2008			
AC-DC	Voltage	90–140 V (Rated 100–127 V) and 180–264 V (rated 200–240 V)			
	Frequency	47–63 Hz (rated 50/60 Hz)			
	Source Interrupt	No loss of data for power line drop-out of 12 msec			
	Surge Non-operating and operating	Unidirectional			
	Line to earth Only	AC Leads	2.0 kV		
	I/O Leads	1.0 kV			
	DC Leads	0.5 kV			
ESD	Air Discharged	12.0 kV			
	Contact Discharge	8.0 kV			
Acoustics Sound Power Measured	Power	<300 W	≥300 W	≥600 W	≥1,000 W
	Servers/Rack Mount Sound Power Level	7.0 BA	7.0 BA	7.0 BA	7.0 BA

Note: (1) For system configuration requirements and limitations, refer to [Appendix D](#) in this document and the online power calculator tool accessible at the following Intel web site: <https://servertools.intel.com/tools/power-calculator/>.

Disclaimer: Intel® server boards contain and support several high-density VLSI and power delivery components that need adequate airflow to cool and remain within their thermal operating limits. Through its own chassis development and testing, Intel ensures that when an Intel® server board and an Intel® server chassis are used together the fully integrated system meets the thermal requirements of these components. Intel cannot be held responsible if components fail or the server board does not operate correctly when published operating and non-operating limits are exceeded.

2.9 System Packaging

The original Intel packaging is designed to provide protection to a fully configured system and tested to meet International Safe Transit Association (ISTA) Test Procedure 3A (2008). The packaging is designed to be reused for shipment after system integration has been completed.

The original packaging includes two layers of boxes: an inner box and the outer shipping box. The packaging also includes various protective inner packaging components.

The boxes and packaging components are designed to function together as a protective packaging system. When reused, the original packaging material must be free of any damage sustained from previous use. In addition, all inner packaging components must be reinstalled in the proper location to ensure adequate protection of the system for subsequent shipment.

Note: The design of the inner packaging components does not prevent improper placement within the packaging assembly. Only one correct packaging assembly allows the package to meet the ISTA Test Procedure 3A (2008) limits. For complete packaging assembly instructions, see the *Intel® Server System M50FCP1UR System Integration and Service Guide*.

Failure to follow the specified packaging assembly instructions may result in damage to the system during shipment.

The 1U shipping box dimensions are:

- External dimensions for the outer shipping box
 - Length: 39.13" (994 mm)
 - Width: 23.31" (592 mm)
 - Height: 11.81" (300 mm)
- Internal dimensions for the Inner box
 - Length: 11.96" (964 mm)
 - Width: 22.13" (562 mm)
 - Height: 9.53" (242 mm)

Note: See the *Intel® Server M50FCP Family Configuration Guide* for product weight information associated with each supported system configuration.

3. System Power

The Intel® Server System M50FCP1UR supports the following power supply options:

- AC 1,300 W (80 PLUS* Titanium)
- AC 1,600 W (80 PLUS* Titanium)

The server system supports up to two modular power supplies. The supplies have tool-less insertion and extraction from two rear facing externally accessible bays. See the following figures.

Notes:

- In dual power supply configurations, both power supplies must be identical. Using two different power supply options concurrently is not supported. This invalid configuration does not provide power supply redundancy and results in multiple errors being logged by the system.
- Selecting a power supply option is dependent on the chosen system configuration and the required power to support it. To determine the power requirements of a chosen system configuration, Intel recommends using its online power calculator tool, which is accessible at the following Intel web site: <https://servertools.intel.com/tools/power-calculator/>.



Figure 21. Power Supply Module Identification

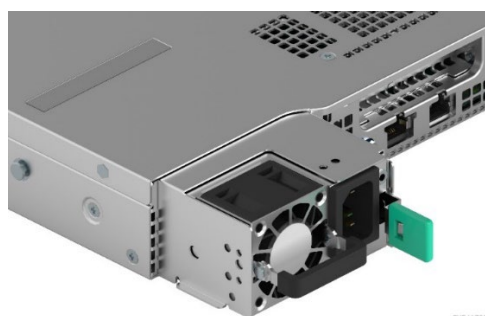

Figure 22. Power Supply Module Partially Out of Chassis



Figure 23. Power Supply Module

3.1 Power Supply Configurations

Embedded platform management automatically determines and configures the power supply configuration based on the number of functional power supplies installed, and the total power draw of the system.

The system supports the following power configurations:

- **1+0** – One functional power supply installed – no power redundancy. Configured if the power requirement of the system stays below the maximum power limit of the one functional power supply.
- **1+1** – Two power supplies installed – redundant power with hot swap support. Configured if the power requirement of the system stays below the maximum power limit of one power supply.
- **2+0** – Two power supplies installed – combined power, no hot-swap support. Configured if the power requirement of the system is greater than the maximum power limit of a single power supply.

3.1.1 Single Power Supply (1+0) Power Configuration

Platform management will set the system power configuration to 1 + 0 (non-Redundant) when it detects that the system has only one power supply installed, or when only one of two power supplies is functional.

With a single functional power supply, the system has no power redundancy and the total available power to the system is limited to the maximum power capacity of the power supply. Anytime the system power draw exceeds the power limit of the power supply, server management limits I/O operations to system memory, processors, or both. This operation is referred to as throttling. Throttling is performed to try to reduce total system power draw. System performance is degraded if throttling occurs.

A power supply event that shuts down the power supply will shut off the server system. A power supply event that shuts down the system generates multiple events and errors that are registered into the system event log (SEL). The state of the System Status LED on the front panel changes to solid amber, denoting that a critical system event has occurred.

3.1.2 Dual Power Supply 1+1 Power Configuration

Platform management will set the system power configuration to 1 + 1 (Redundant Power) if it detects two functional power supplies and the total power draw of the given system configuration is less than or equal to the power limit of a single power supply. In a redundant power configuration, if one power supply fails, the backup or secondary power supply will automatically engage and provide the necessary power to maintain optimal system operation.

With a power supply failure, the BMC generates several events that are registered to the system event log and changes the system power configuration to 1 + 0 (non-redundant) (see section 3.1.1) until the failed power supply is replaced. In addition, the System Status LED on the front panel will change to Blinking Green, denoting a degraded but operational system state

Power supplies are hot-swappable, allowing a failed power supply to be replaced without having to first power down the system. After replacing a failed power supply, platform management will automatically change the power configuration to either 1 + 1 or 2 + 0 depending on the total system power draw at the time the new power supply was detected. The System Status LED state changes back to solid green, denoting the system is operating in a fault free normal state.

3.1.3 Dual Power Supply 2+0 Power Configuration

Platform management will set the system power configuration to 2 + 0 (Combined Power) if it detects two functional power supplies and the total power draw of the given system configuration exceeds the limits of one power supply. In this configuration, power from both power supplies will be used to supply the system with power to support an optimal system operation.

Combined power does not mean that twice as much power is available to the system. Enough power will be pulled from both power supplies to support an optimal system operation.

In a 2 + 0 power configuration, if a power supply fails, platform management will initiate throttling, which limits system I/O operations to system memory, processors, or both. Throttling is only effective if the total system power draw is reduced enough to allow the system to operate with the single remaining power supply. System performance will be degraded if throttling is enabled.

When platform management detects a power supply has shut down, several system error and status change events are logged to the system event log. The System Status LED changes to Blinking Green, denoting a degraded but operational system state. In addition, system power changes to a nonredundant 1 + 0 configuration (see previous section) until the failed power supply is replaced.

A failed power supply is hot-swappable if the system is still operational with the remaining power supply. The failed power supply can be replaced without having to first power down the system. After replacing a failed power supply and with the system operating normally, platform management automatically disables throttling, and changes the power configuration to either 1 + 1 or 2 + 0 depending on the total system power draw.

Should throttling fail to reduce power enough for the system to be supported by a single power supply, then the system will shut down. Several system events will be logged to the system event log, and the state of the System Status LED on the front panel changes to solid amber, denoting that a critical system event has occurred.

3.2 Intel® Online Power Calculator Tool

For system integrators that would like to determine the system power draw and heat dissipation for a specific system configuration, Intel makes available an on-line power calculator tool accessible at the following Intel web site:

<https://servertools.intel.com/tools/power-calculator/>

3.3 Closed Loop System Throttling (CLST)

Closed Loop System Throttling (CLST) is supported. CLST prevents the system from crashing if a power supply module is overloaded or overheats. If the system power reaches a pre-programmed power limit, CLST throttles system memory and/or processors to reduce power. System performance is degraded if throttling occurs.

3.4 Smart Ride Through (SmaRT) Throttling

Smart Ride Through (SmaRT) throttling is supported. SmaRT increases the reliability of a system operating in a heavy power load condition and to remain operational during an AC line dropout event.

When AC voltage is too low, a fast AC loss detection circuit inside each installed power supply asserts an SMBALERT# signal to initiate a throttle condition in the system. System throttling reduces the bandwidth to both system memory and processors that, in turn, reduces the power load during the AC line drop out event.

3.5 Power Supply Cold Redundancy

In dual power supply 1 + 1 redundant power configurations, by default, the BMC enables support for Cold Redundancy mode. Cold redundancy can put the redundant power supply into a low power (almost off) standby state. This operation is done to save energy at system idle while still being able to turn back on fast enough (within 100 µsec) in case of a power supply failure to keep the system operating normally.

In Cold Redundancy mode, the BMC assigns and identifies each power supply as either “Active” or “Cold Standby”. The Active power supply provides the system with power. The cold standby power supply is placed in a low power standby state and is a backup to the active power supply in case of failure.

To support highest long-term reliability of each power supply, the BMC schedules a rolling reconfiguration. Installed power supplies alternate between being the “Active” and the “Cold Standby” that allows for equal loading over the lifetime of each power supply.

The BMC uses the `Cold_Redundancy_Config` command to both set each power supply’s role in cold redundancy and to enable/disable cold redundancy.

The following events trigger a reconfiguration of the power supplies using the `Cold_Redundancy_config` command:

- Source power ON
- PSON power ON
- Power supply failure
- Power supply inserted into system

3.6 Power Supply Specification Overview

The Intel® Server System M50FCP1UR supports the following power supply options:

- AC 1,300 W (80 PLUS Titanium)
- AC 1,600 W (80 PLUS Titanium)

AC power supplies are auto-ranging and power factor corrected.

The following sections provide an overview of select power supply features and functions.

Note: Full power supply specification documents are available upon request. Power supply specification documents are classified as Intel Confidential and require a signed NDA with Intel before being made available.

3.6.1 Power Supply Module Efficiency

Each power supply option is rated to meet specific power efficiency limits based on their 80 PLUS power efficiency rating: Titanium.

Table 4 defines the required minimum power efficiency levels based on their 80 PLUS efficiency rating at specified power load conditions: 100%, 50%, 20%, and 10%.

The AC power supply efficiency is tested over an AC input voltage range of 115 VAC to 220 VAC.

Table 4. 1,300 W and 1,600 W AC Power Supply Option Efficiency (80 PLUS* Titanium)

80 PLUS TITANIUM	Loading	100% of Maximum	50% of Maximum	20% of Maximum	10% of Maximum
	Minimum Efficiency		91%	96%	94%

3.6.2 AC Power Cord Specifications

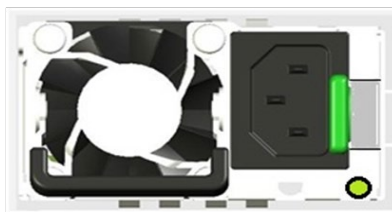

Figure 24. AC Power Cable Connector

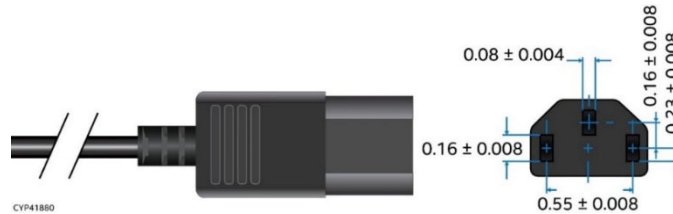

Figure 25. AC Power Cord Specification

The AC power cord used must meet the specification requirements listed in the following table.

Table 5. AC power Cord Specifications

Item	Description
Cable Type	SJT
Wire Size	14 AWG
Temperature Rating	105 °C
Amperage Rating	10 A at 240 V
Voltage Rating	240 VAC

3.7 AC Power Supply Features

The following sections describe features supported by the AC power supply options.

3.7.1 Power Supply Status LED

A single bi-color LED on the power supply indicates power supply status. The operational states of this bi-color LED are defined in the following table.

Table 6. LED Indicators

LED State	Power Supply Condition
Solid green	Output ON and OK.
Off	No source power to all power supplies.
1 Hz blinking green	Source power present/only 12 VSB on (PS off) or PS in cold redundant state.
Solid amber	Source power cord unplugged, or source power lost; with a second power supply in parallel still with AC input power, or power supply critical event causing a shutdown; failure, over current protection, over voltage protection, fan fail.
1 Hz blinking amber	Power supply warning events where the power supply continues to operate; high temp, high power, high current, slow fan.
2 Hz blinking green	Power supply firmware updating.

3.7.2 Protection Circuits

Each installed power supply module includes several protection circuits that shut down the power supply if a defined operating threshold is exceeded.

3.7.2.1 Over Current Protection

Each installed power supply is protected against excess current. The power supply unit shuts down for a specific time after crossing current thresholds. A power supply that is shut down due to an exceeded protection circuit threshold can be reset by removing source power for 15 seconds.

Table 7. Over Current Protection for 1,300 W Power Supplies

Output Voltage	Input Voltage Range	Over Current Limits	Over Current Protection Delay
+12 V	180–264 VAC	132 A minimum / 138 A maximum	50 msec minimum / 200 msec maximum
		152 A minimum / 160 A maximum	5 msec minimum / 20 msec maximum
	90–140 VAC	72 A minimum / 77 A maximum	50 msec minimum / 200 msec maximum
		103 A minimum / 107 A maximum	5 msec minimum / 20 msec maximum

12 VSB	90–264 VAC	2.5 A minimum / 3.5 A maximum	5 msec minimum / 20 msec maximum
---------------	------------	-------------------------------	----------------------------------

Table 8. Over Current Protection for 1,600 W Power Supplies

Output Voltage	Input Voltage Range	Over Current Limits	Over Current Protection Delay
+12 V	180–264 VAC	155 A minimum / 165 A maximum	30 msec minimum / 100 msec maximum
12 VSB	90–264 VAC	3.6 A minimum / 4 A maximum	1 msec minimum / 100 msec maximum

Table 9. Over Voltage Protection (OVP) Limits, 1,300 W and 1,600 W Power Supply

Output Voltage	Minimum (V)	Maximum (V)
+12 V	13.5	14.5
+12 VSB	13.5	14.5

3.7.2.2 Over Temperature Protection (OTP)

Each installed power supply is protected against over temperature conditions caused by loss of fan cooling or excessive ambient temperature. The power supply unit shuts down during an OTP condition. Once the power supply temperature drops to within specified limits, the power supply restores power automatically.

Note: The 12 VSB always remains on while the power supply is connected to the power source.

4. Thermal Management Overview

The embedded platform management subsystem is responsible for keeping the system operating reliably and with best performance. The integrated baseboard management controller (BMC) embedded within the Aspeed® AST2600 Remote Management Server Processor is the component most responsible for determining and implementing system actions under varying environmental and operational conditions.

Thermal management is critical to system performance and long-term reliability. The system is designed to operate at external ambient air temperatures ranging from 10 °C to 35 °C, and with limited excursions at temperatures up to 45 °C. The system must maintain a steady airflow through the system to expel all hot air generated within it.

Using eight dual rotor system fans, an embedded fan within each installed power supply, and other system components, the system pulls cool air in from the front, channels it over and through several high heat generating components and areas within the chassis, and then pushes the hot air out the back. This operation is intended to prevent the components from overheating, allowing the system to operate optimally.

The system supports fan redundancy. Should a single fan rotor fail, the system will keep internal system temperatures below maximum thermal limits. See [Appendix D](#) for thermal configuration limits for fan redundancy support. Thermal redundancy is lost if more than one fan rotor fails.

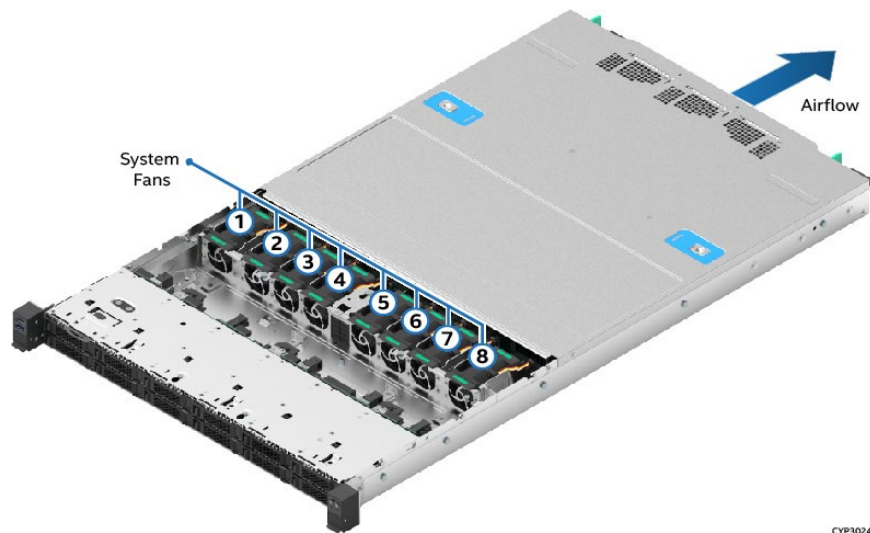

Figure 26. System Airflow and Fan Identification

The following tables provide airflow data associated with the Intel® Server System M50FCP1UR. This data is provided for reference purposes only. The data was derived from actual wind tunnel test methods and measurements using fully configured (worst case) system configurations. Different system configurations may produce slightly different data results. In addition, the cubic feet per minute (CFM) data provided using server management utilities that use platform sensor data may vary slightly from the data listed in the tables.

Table 10. System Volumetric Airflow – M50FCP1UR204

System Fan	Power Supply Fan	Total Airflow (CFM)
100%	Auto	138.0
100%	100%	139.0
55%	Auto	60.0

Table 11. System Volumetric Airflow – M50FCP1UR212

System Fan	Power Supply Fan	Total Airflow (CFM)
100%	Auto	114
100%	100%	116
55%	Auto	55

4.1 Thermal Operation and Configuration Requirements

To keep the system operating within supported thermal limits, the system must adhere to following operating and configuration guidelines:

- The system is designed to operate with best performance and support long term reliability targets when external ambient temperatures stay within a range of 10 °C to 35 °C (ASHRAE Class A2). See [Table 3](#) for extended temperature support details.
- The system can operate up to 40 °C (ASHRAE Class A3) for up to 900 hours per year and still support long term reliability targets. However, system performance will be impacted operating the system at temperatures above 35 °C.
- The system can operate up to 45 °C (ASHRAE Class A4) for up to 90 hours per year and still support long term reliability targets. However, system performance will be impacted operating the system at temperatures above 35 °C.

Specific configuration requirements and limitations are documented in [Appendix D](#). The requirements and limitations are also in the online power calculator tool accessible at the following Intel web site:

<https://servertools.intel.com/tools/power-calculator/>.

- The system top cover must be installed when the system is operational.
- The air baffles located on the left and right edges of the server board must be installed when the system is operational. These components assist in directing air flow within the chassis.
- In a single processor configuration, the processor and heat sink must be installed in to the CPU 0 processor socket. A single processor configuration where the processor is installed in the CPU 1 processor socket is not supported.
- PCIe add-in card airflow support limits for Riser Slot #1, Riser Slot #2, and the PCIe Interposer Riser Slot is 300 LFM for each slot.

Note: Most PCIe add-in cards have cooling requirements of airflow up to 100 LFM (0.5 m/s), while some of the more difficult to cool cards have airflow requirements of up to 200 LFM (1 m/s).

- All front drive bays must be populated with an SSD or supplied drive blank.
- All black memory slots must be populated with a memory module or factory installed DIMM blank (See [Figure 27](#)). All system configurations ship from Intel with DIMM blanks preinstalled. Preinstalled DIMM blanks should only be removed when installing a memory module in its place.

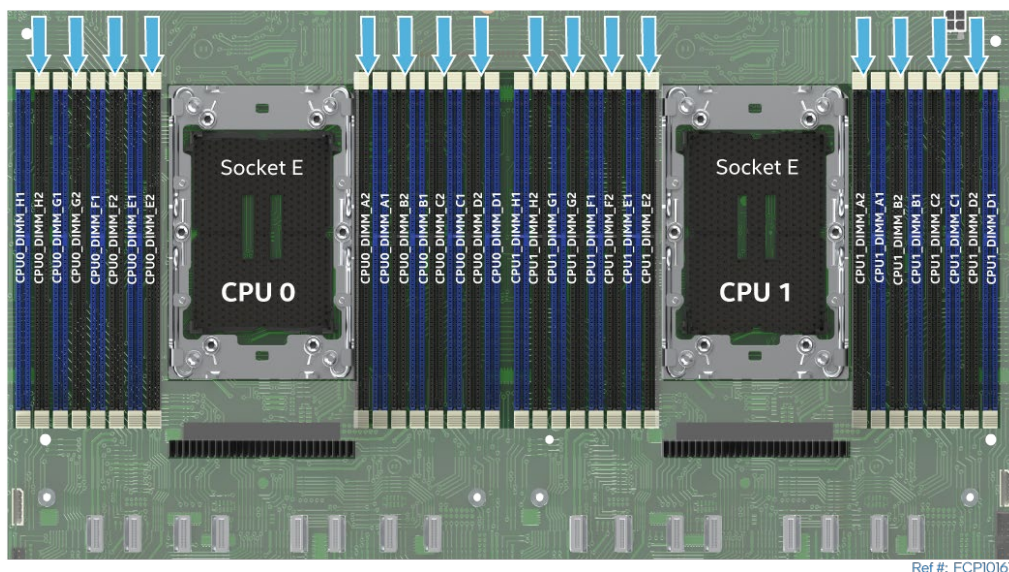



Figure 27. System Memory Module / DIMM Blanks Configuration

Note: To maintain system thermals while the system is operational, black memory slots identified with  must be populated with a memory module or supplied DIMM blank.

4.2 Thermal Management Overview

To maintain the necessary airflow within the system, all previously listed configuration requirements and the system top cover, need to be properly installed when the system is operational. For optimal system performance, the external ambient temperature should remain below 35 °C and all system fans should be operational.

The system is designed to support fan redundancy. Fan redundancy can be supported for most system configurations when all the following are true:

- The system is configured with two power supply modules
- All fan rotors within the system are operational
- The external ambient air remains at or below 35 °C (ASHRAE Class A2 limits)

See [Appendix D](#) for supported configurations in fan failed mode.

If a single fan rotor within the system fails, platform management adjusts airflow of the remaining fans, and manages other platform features to maintain system thermals. Fan redundancy is lost if more than one fan rotor within the system fails.

For system configurations that support fan redundancy, if a fan rotor fails, integrated platform management does the following:

- Changes the state of the system status LED to blinking green
- Reports an error to the system event log
- Automatically adjusts fan speeds of the remaining operational fans as needed to maintain system temperatures below maximum thermal limits.

Note: All system fans are controlled independently of each other. The fan control system may adjust fan speeds for different fans based on increasing/decreasing temperatures in different thermal zones within the chassis.

If system temperatures continue to increase with the system fans operating at their maximum speed, platform management may begin to throttle bandwidth of either the memory subsystem, the processors, or both. It does this action to keep components from overheating and keep the system operational. With throttling engaged, system performance will be impacted. Throttling will stay engaged until all thermal sensors read temperatures that are below preprogrammed critical limits.

The power supply is protected against over temperature conditions caused by excessive ambient temperature. If such condition occurs, the power supply module shuts down to protect itself from overheating.

If system thermals increase to a point beyond the maximum thermal limits, the system shuts down, the system status LED changes to solid amber, and the event is logged to the system event log.

If the temperature within the power supplies increases to a point beyond their maximum thermal limits, or if a power supply fan should fail, the power supply shuts down.

4.3 System Fans

Eight 40 x 40 x 56-mm dual rotor system fans and an embedded fan for each installed power supply module provide the primary airflow for the system.

Each system fan supports the following:

- Hot-swappable.
- Blind-mated to a matching 8-pin connector on the server board.
- Designed for tool-less insertion and extraction from the fan assembly.
- Has a tachometer signal that allows the integrated BMC to monitor its status.
- Fan speed is controlled by integrated platform management. As system temperatures fluctuate high and low, the integrated BMC firmware increases and decreases the speeds to specific fans within the fan assembly to regulate system thermals.

All system fans are hot-swappable and require no tools for replacement. However, a faulty system fan with dual rotors may still have a functional rotor. Because fan rotors spin at very high speeds, extreme caution should be taken when performing a hot replacement of a system fan. When removing a system fan while the system is operational, use two hands to grasp the two green tabs found on the top edges of the fan assembly and pull straight up. This removes the fan from its housing and disconnects the fan connector from the server board. Keep fingers away from the front and back fan grates and let the rotor stop completely before handling the system fan. For safety, Intel recommends replacing a faulty system fan with the system powered off whenever possible.

Note: For further information on fan speed control, see [Section 0](#).

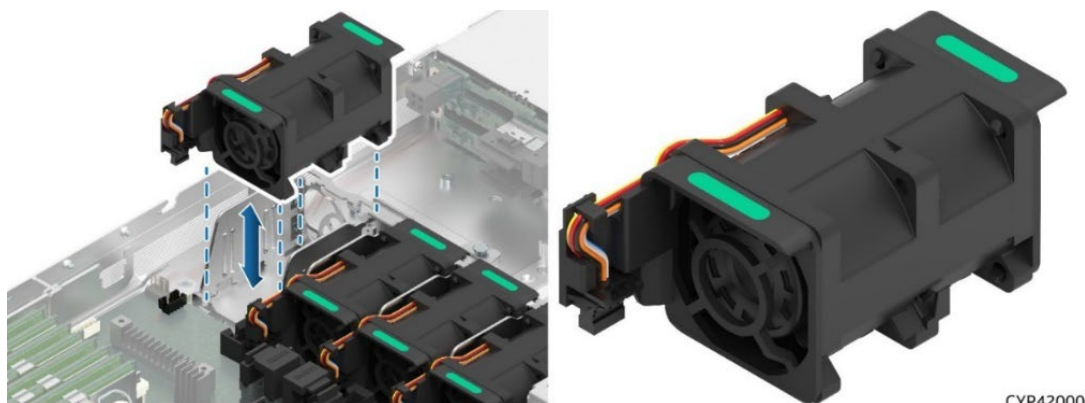

Figure 28. System Fan Assembly

4.4 Power Supply Module Fans

Each installed power supply module includes embedded (nonremovable) 38-mm fans. These fans are responsible for airflow through the power supply module and are managed by the fan control system. If a fan fails, the power supply shuts down.

4.5 Fan Speed Control

The BMC controls and monitors the system fans. Each fan is associated with a fan speed sensor that detects a fan failure. It may also be associated with a fan presence sensor for hot-swap support. For redundant fan configurations, the fan failure status and fan presence status determine the fan redundancy sensor state.

The system fans are divided into fan domains, each of which has a separate fan speed control signal, and a separate configurable fan control policy. A fan domain can have a set of temperature and fan sensors associated with it. The sensors are used to determine the current fan domain state.

A fan domain has three states: sleep, boost, and nominal. The sleep and boost states have fixed fan speeds associated with them. The nominal state has a variable speed determined by the fan domain policy. An OEM defined SDR record can be used to configure the fan domain policy.

The fan domain state is controlled by several factors listed in the following bullets in order of precedence from high to low. If any of these conditions apply, the fans are set to a fixed boost state speed.

- An associated fan is in a critical state or missing. The SDR describes which fan domains are boosted in response to a fan failure or removal in each domain. A fan cannot be detected if it is removed when the system is in fans-off mode.
- Any associated temperature sensor is in a critical state. The SDR describes which temperature-threshold violations cause fan boost for each fan domain.
- The BMC is in a firmware update mode, or the operational firmware is corrupted.

4.6 Processor Heat Sink Options

The Intel® Server System M50FCP1UR supports two types of processor heat sinks. A standard 1U heat sink and an Enhanced Volume Air Cooling (EVAC) heat sink (See [Figure 29](#)).

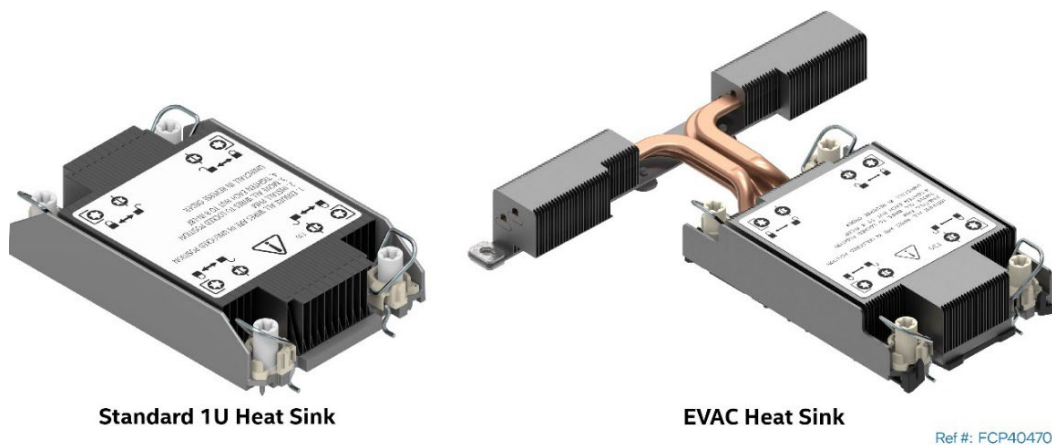

Figure 29. Supported Processor Heat Sinks

The type of heat sink used depends on the system thermal requirements.

The 2.5" x 4 front drive system must use the EVAC heat sink. The 2.5" x 12 front drive systems must use the standard 1U heat sink.

5. PCI Express* (PCIe*) Subsystem Overview

4th & 5th Gen Intel® Xeon® Scalable processors provide up to 80 PCIe bus lanes that support the PCIe Express Base Specification, Revision 5.0 and Compute Express Link Specification 1.1 (CXL 1.1).

PCIe bus lanes from each processor and the Intel® C741 chipset are used to support various system features as shown in the following architectural diagram.

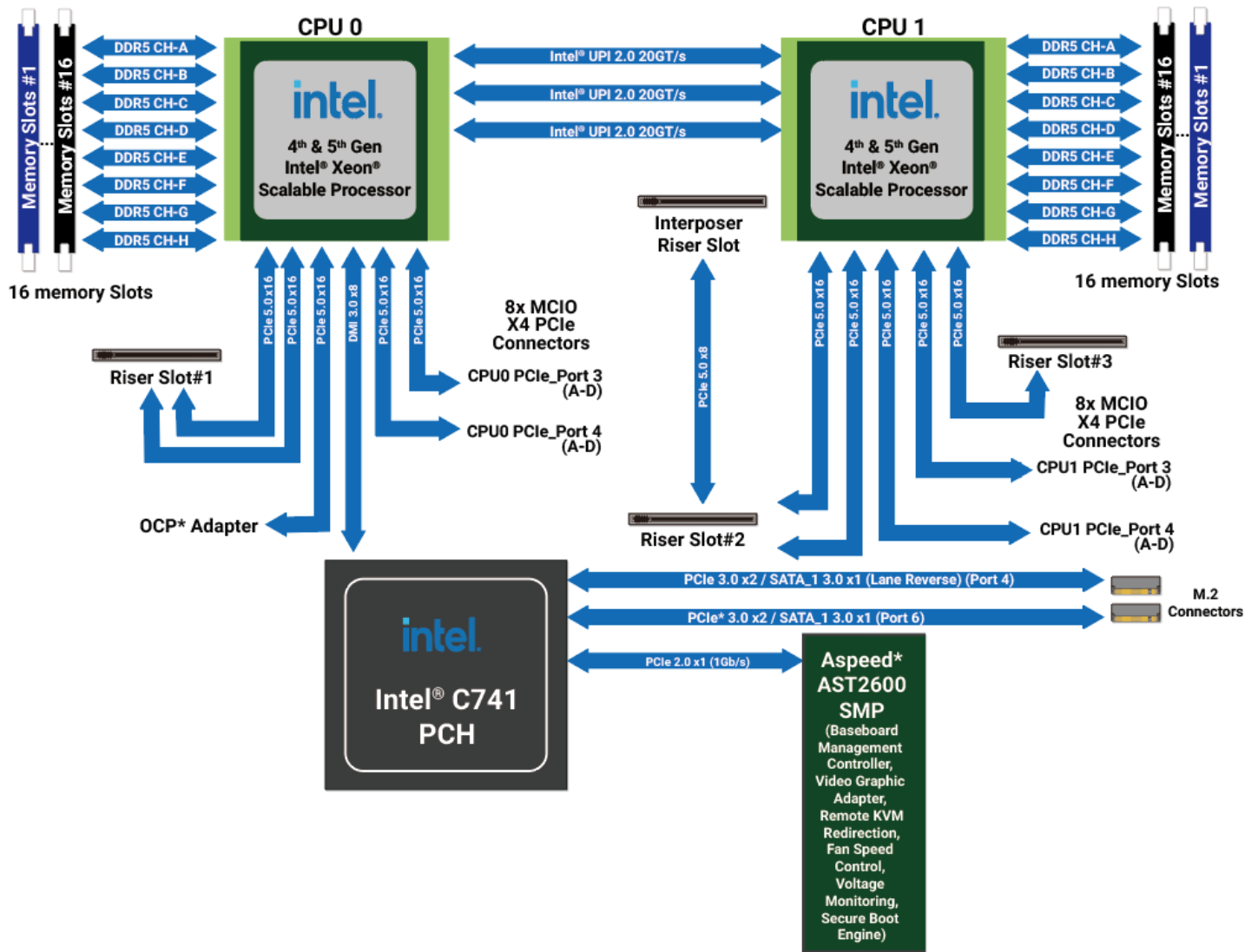

Figure 30. PCIe Subsystem Architecture

Note: A dual processor configuration is required to support all onboard PCIe features.

Intel® UPI link speed 20GT/s depends on 5th Gen processor.

For more CXL information refer to the 4th and 5th Gen Intel® Xeon® Scalable processors family BIOS Firmware External Product Specification (EPS).

Table 12. Processor / Chipset PCIe* Port Routing

Host	Port	Width	Gen.	Usage
CPU 0	Port 0A–0D	x16	4.0	OCP* Adapter connector
	Port 1A–1D	x16	5.0	Riser Slot #1 [15:0]
	Port 2A–2D	x16	5.0	Riser Slot #1 [31:16]
	Port 3A–3D	x16	5.0	Server board PCIe MCIO connectors
	Port 4A–4D	x16	5.0	Server board PCIe MCIO connectors
	DMI3	x8	3.0	Chipset PCH
CPU 1	Port 0A–0D	x16	5.0	Riser Slot #3 [15:0]
	Port 1A–1D	x16	5.0	Riser Slot #2 [31:16]
	Port 2A–2D	x16	5.0	Riser Slot #2 [15:0]
	Port 3A–3D	x16	5.0	Server board PCIe MCIO connectors
	Port 4A–4D	x16	5.0	Server board PCIe MCIO connectors
Chipset PCH	Port 8–9	x2	3.0	M.2 Connector- SATA / PCIe
	Port 10–11	x2	3.0	M.2 Connector- SATA / PCIe

On the server board, PCIe bus lanes are used to support the following features:

- Three PCIe Riser Card slots + One Interposer Riser Slot
- One OCP 3.0 Interface connector
- Sixteen PCIe MCIO* connectors for NVMe support (Up to twelve used in the 1U system).
- Two M.2 SSD connectors. See [Section 6.6](#) for details.

This chapter provides an overview of each.

5.1 PCIe* Riser Card Support

The Intel® Server M50FCP1UR has support for two PCIe riser cards plus one PCIe Interposer card, identified as: Riser Slot #1, Riser Slot #2, and PCIe Interposer Riser.

Note: Riser slot #3 on the server board is not used in 1U system configurations.

With two PCIe riser cards and the PCIe interposer card installed, the system can support up to three PCIe add-in cards.

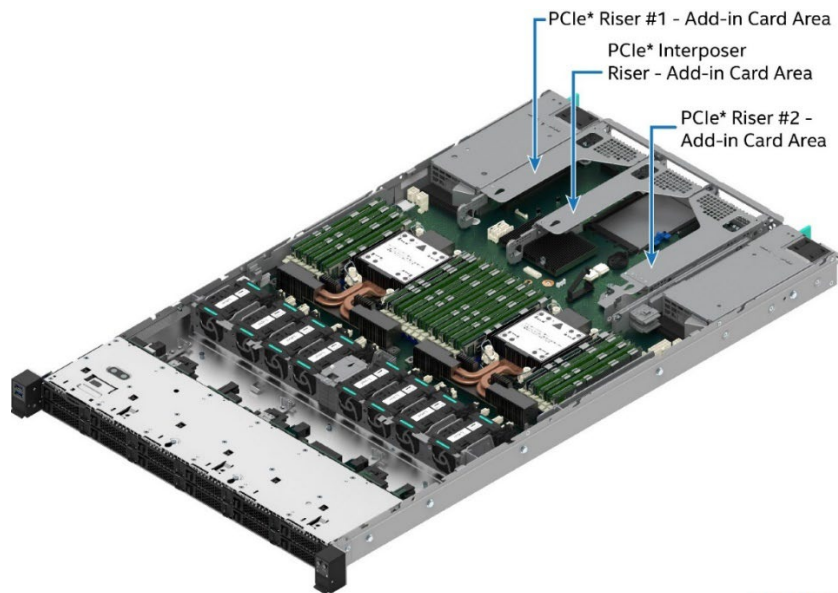

Ref #: FCP20281

Figure 31. PCIe* Riser Card Slot Identification

PCIe add-in cards are installed into a riser card assembly consisting of a riser card bracket, a riser card, and a filler plate.

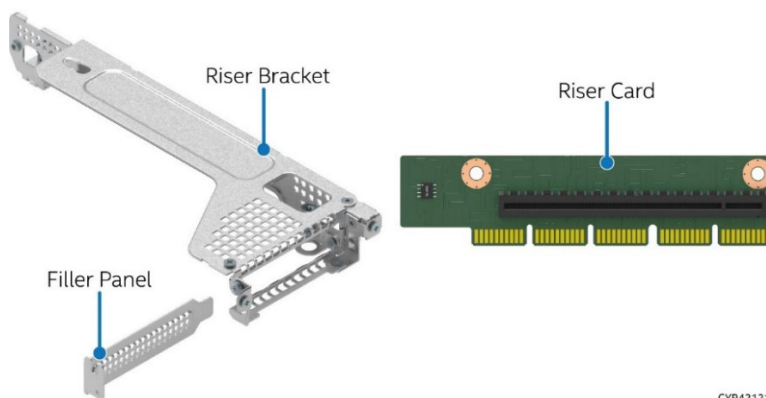

CYP42121

Figure 32. Riser Card Assembly Components

Riser card assemblies are installed into the system by positioning an alignment stud on the riser bracket with an alignment slot on the chassis back panel. The assembly is then pushed down until the riser card is firmly seated within the riser slot on the server board. The riser assembly is secured to the server board using a pair of captive screw heads on the riser bracket, which are tightened onto a pair of threaded captive screws protruding up from the server board.

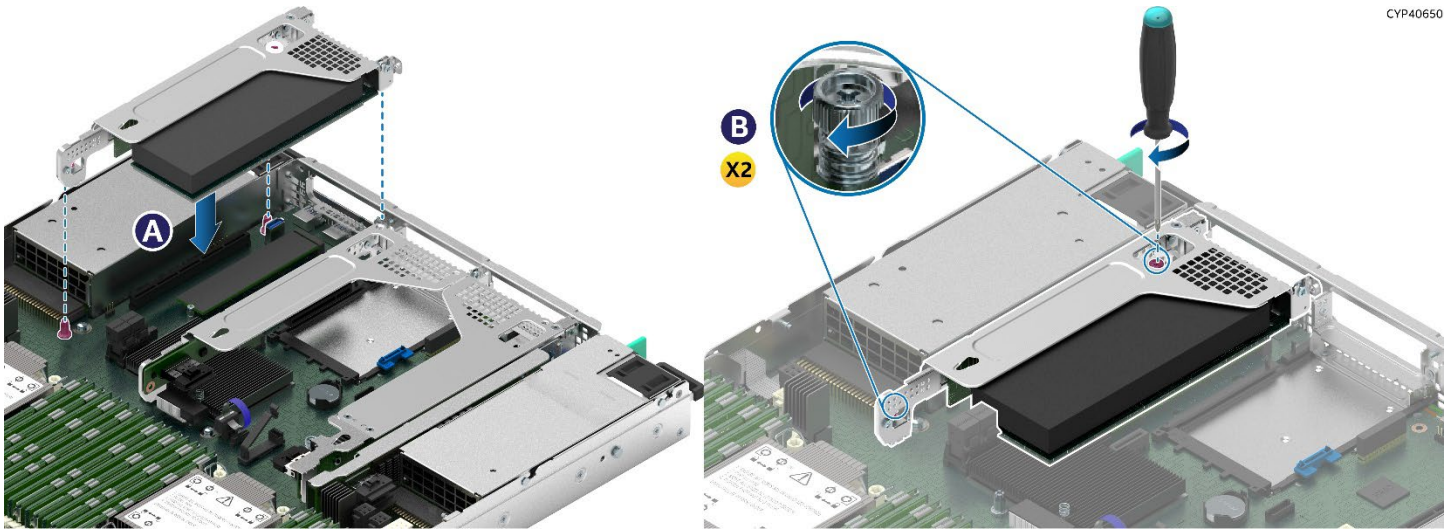

Figure 33. Add-in Card Placement into Server System Chassis

Depending on the system configuration, the server system may or may not come pre-configured with riser card options installed. However, all system configurations include the mounting bracket and filler plates for each supported riser card option.

All riser card assemblies support the following riser card specifications:

- Low profile
- Half length

Notes:

- The maximum airflow supported by all three add-in card slots is 300 LFM. System integrators should identify PCIe* add-in card airflow requirements from vendor specifications when integrating any add-in card into the system to ensure the chosen PCIe* add-in card slot can meet the card's airflow requirements.

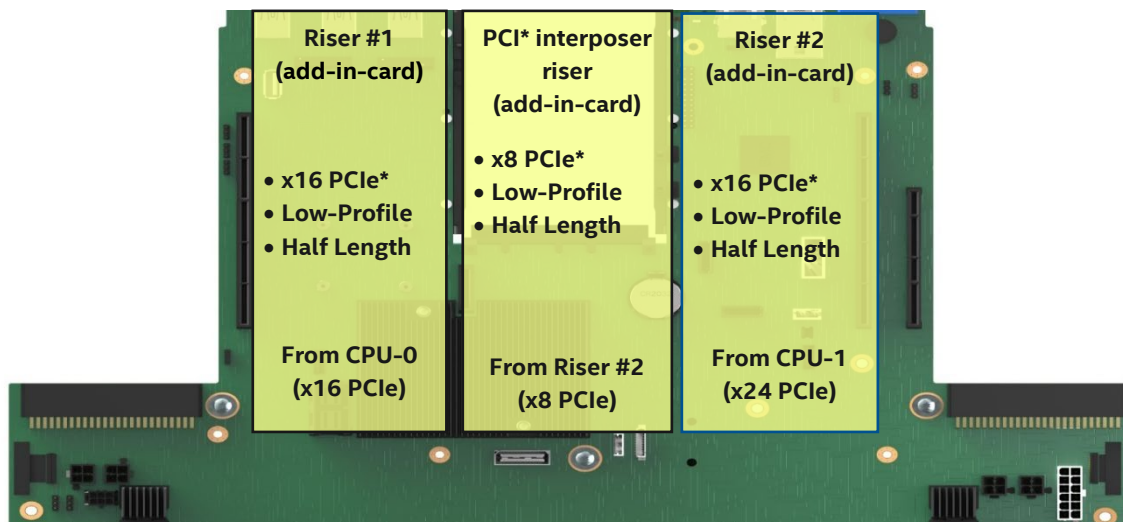

Figure 34. PCIe Add-in Card Support

5.2 PCIe* Riser Card Options

Several PCIe riser card options are available for this server system family. The following sections list the different options. The available riser card options are riser slot specific and are not interchangeable between the server board riser slots.

The Intel® Server System M50FCP1UR supports PCIe bifurcation for each riser slot. To change the PCIe bifurcation setting, access the BIOS setup utility by pressing <F2> key during POST. Navigate to the following menu: **Advanced > Integrated IO Configuration > PCIe Slot Bifurcation Setting**

Note: In any riser card option, each PCIe* add-in card slot is connected to clock signals. When a PCIe* add-in card slot is configured with any of the available bifurcation options in the BIOS, the slot provides clock signals to only one of the bifurcated PCIe* data lane groups. The add-in card must provide clock signals to the remaining PCIe* data lane groups.

In the following sections, HL = Half Length, LP = Low Profile.

5.2.1 1-Slot PCIe* Riser Card for Riser Slot #1 (iPC FCP1URISER1)

The 1-slot PCIe riser card option supports:

- One LP/HL, single-width add-in card slot (x16 electrical, x16 mechanical)

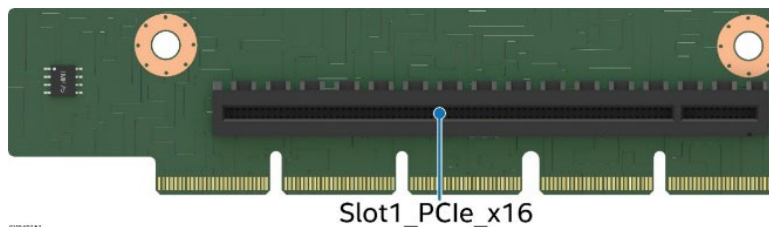

Figure 35. PCIe* Riser Card for Riser Slot #1

Supported PCIe Bifurcation: x16 / x8x8 / x8x4x4 / x4x4x8 / x4x4x4x4

Table 13. PCIe* Riser Card Connector Description

Connectors	Description	Maximum Power Available (W)
Slot1_PCl_e_x16	CPU 0: Ports 2A through 2D (x16 electrical, x16 mechanical)	75

5.2.2 1-Slot PCIe* Riser Card for Riser Slot #2 (iPC FCP1URISER2)

The 1-slot PCIe riser card option supports:

- One LP/HL, single-width add-in card slot (x16 electrical, x16 mechanical)

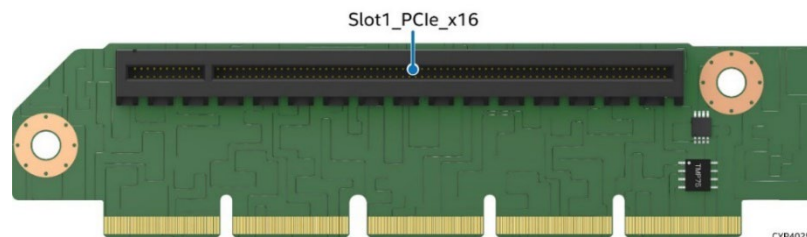

Figure 36. PCIe* Riser Card for Riser Slot #2

Supported PCIe Bifurcation: x16 / x8x8 / x8x4x4 / x4x4x8 / x4x4x4x4

Table 14. PCIe* Riser Card Connector Description

Connector	Description	Maximum Power Available (W)
Slot1_PCl_e_x16	CPU 1: Ports 1A through 1D (x16 electrical, x16 mechanical)	75

5.2.3 1-Slot PCIe* MCIO Riser Card for Riser Slot #2 with PCIe Interposer Riser Card Support

Intel offers a 1U riser card accessory kit (iPC - FCP1URISER2KIT) that provides the server board with the option of adding a third PCIe add-in card into a 1U server system. The kit includes the following:

- 1 – PCIe MCIO riser card for Riser Slot #2
- 1 – PCIe interposer riser card
- 1 – PCIe interposer cable

The PCIe MCIO riser card is only supported when installed into Riser Slot #2 on the server board. The riser card supports the following features:

- One LP/HL add-in card slot (x16 electrical, x16 mechanical)
- One x8 PCIe MCIO* Interposer Cable Connector

Note: The MCIO* Interposer cable connector on the PCIe MCIO Riser card does not support and cannot be used to provide PCIe signals to NVMe drives.

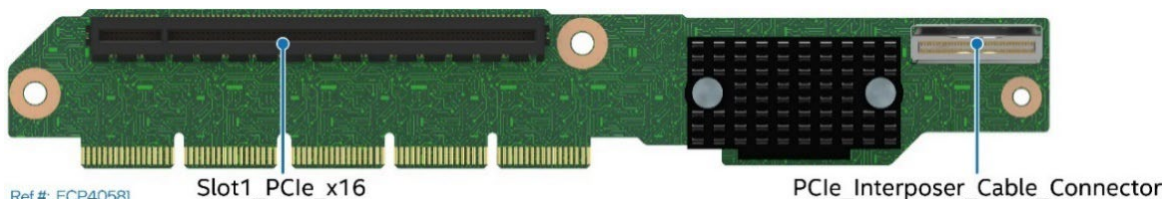

Figure 37. PCIe* Riser Card for Riser Slot #2

Table 15. PCIe* Riser Card Connector Description

Connector	Description	Maximum Available Power (W)
Slot1_PCl_e_x16	CPU 1: Ports 2A through 2D (x16 electrical, x16 mechanical)	75
PCl_e_Interposer_Cable_Connector	CPU 1: Ports 1A through 1B (x8 electrical, x8 mechanical)	N/A

The PCIe interposer riser card option is designed to install into the Interposer Riser slot on the server board and supports the following features:

- One LP/HL, single-width PCIe add-in card slot (x8 electrical, x8 mechanical)
- One x8 PCIe MCIO connector

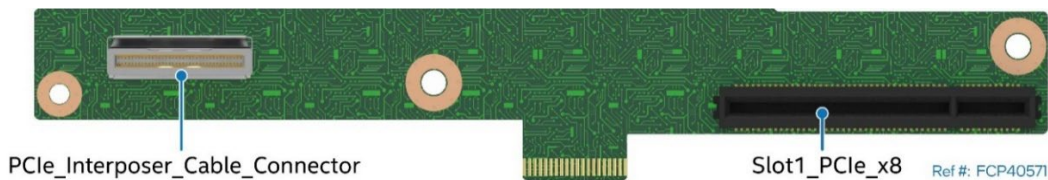

Figure 38. PCIe* Interposer Riser Card

Table 16. PCIe* Interposer Riser Card Connector Description

Connector	Description	Maximum Available Power (W)
Slot1_PClE_x8	CPU 1: Ports 1A through 1B (x8 electrical, x8 mechanical)	25
PClE_Interposer_Cable_Connector	CPU 1: Ports 1A through 1B (x8 electrical, x8 mechanical)	N/A

To use the interposer riser card, the PCIe interposer cable must be installed to the matching x8 PCIe MCIO* connectors found on the PCIe MCIO riser card and the PCIe Interposer card (See Figure 39)

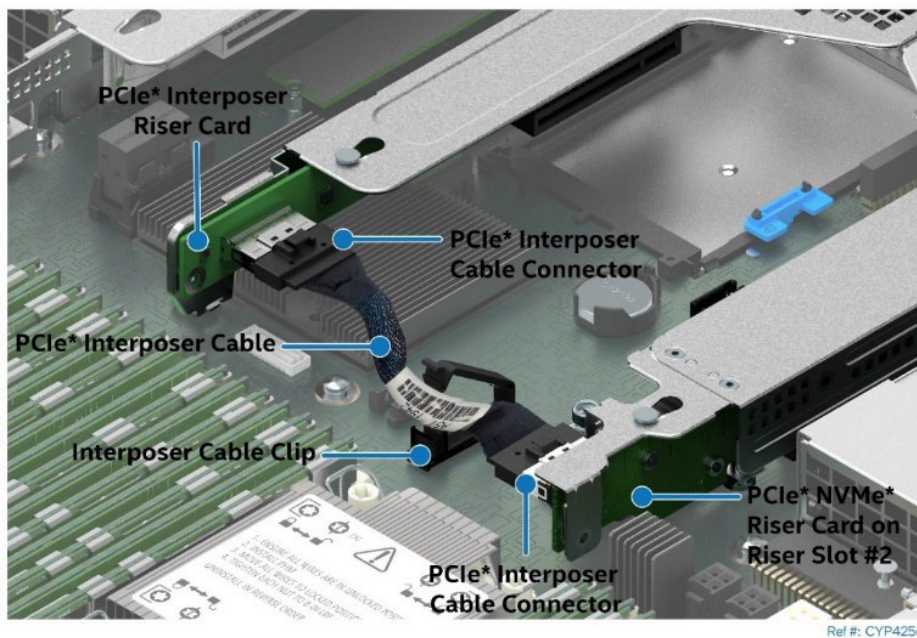

Figure 39. PCIe* Interposer Riser Card to PCIe* Riser Card Connectivity

5.3 Intel® Ethernet Network Adapter for OCP* Support

The Intel® Server System M50FCP1UR supports several types of Intel® Ethernet Network Adapters. Supported adapters adhere to the Open Compute Project (OCP) 3.0 specification, which utilizes an edge connector interface to the server board. This allows the card to be serviced from the back of the chassis instead of having to access the inside of the chassis to install or remove it.

Note: Reference the Intel® Server M50FCP Family Configuration Guide for a list of supported adapter cards.

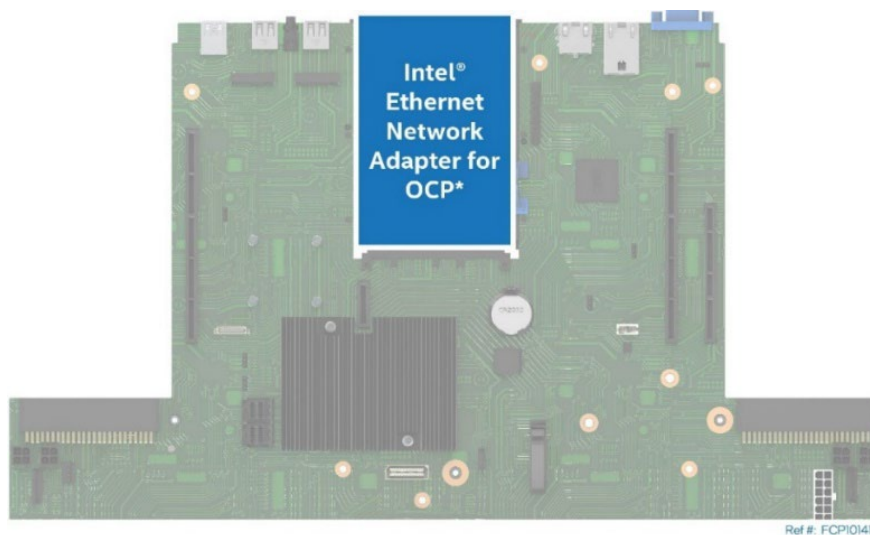

Figure 40. Intel® Ethernet Network Adapter for OCP* Placement

With the Intel® Server System M50FCP1UR, OCP add-in cards are installed from the outside of the chassis into an OCP bay. A filler panel must be removed from the OCP bay before an OCP add-in card can be installed (See [Figure 41](#)).

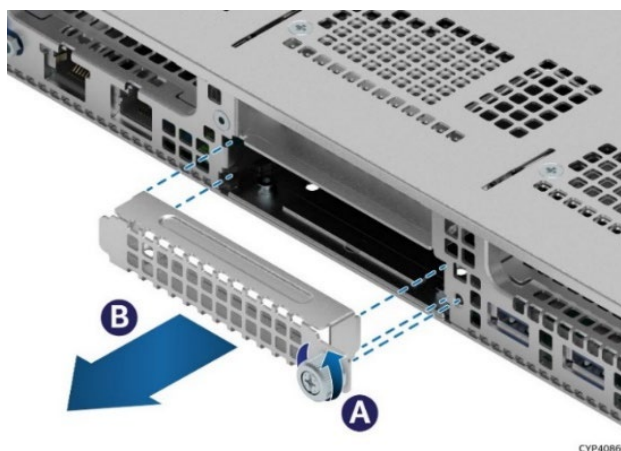

Figure 41. OCP* Bay Filler Removal

OCP 3.0 add-in cards support different methods of securing the card to the system. With the Intel® Server System M50FCP1UR, only OCP 3.0 add-in cards with a pull-tab and fastener screw or internal lock are supported.

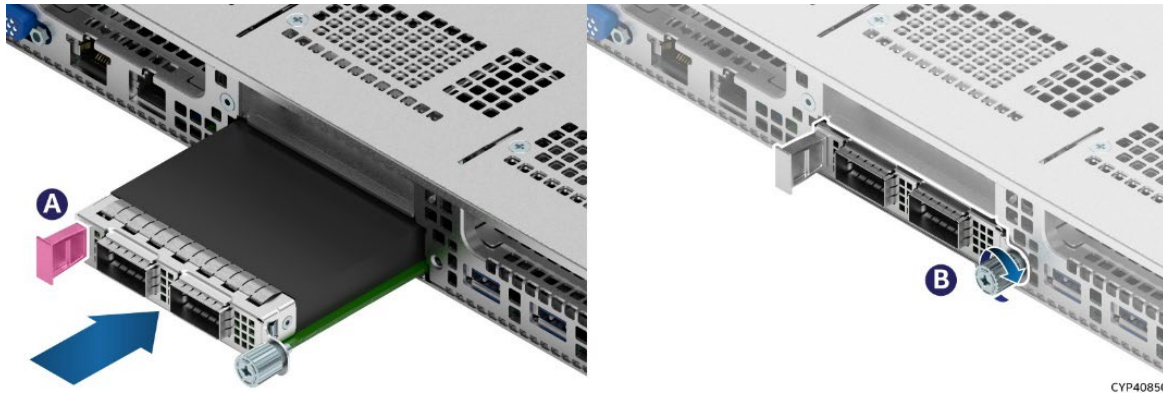

Figure 42. OCP* Add-in Card with Pull Tab Installation

All systems include a blue internal lock feature, attached to the OCP rail, to support OCP add in cards that require an internal locking mechanism (See Figure 43).

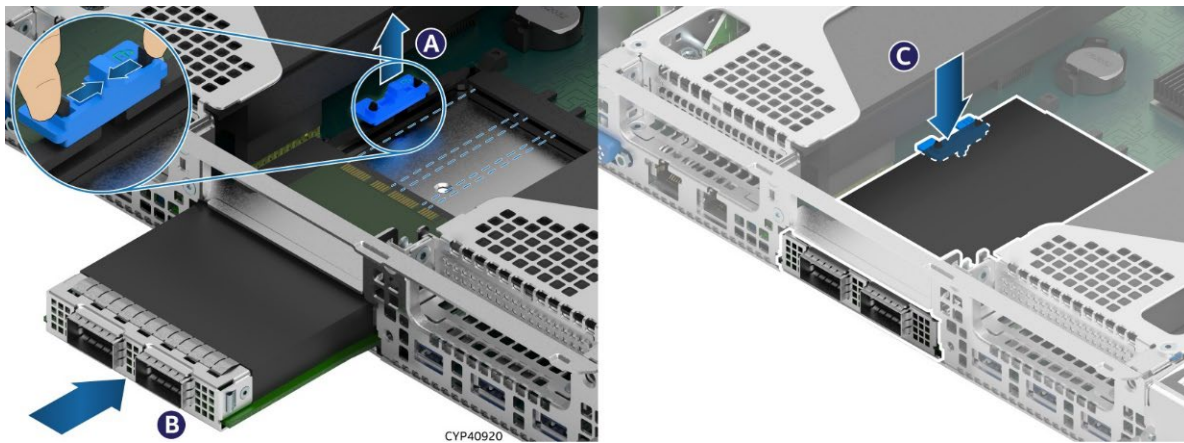

Figure 43. OCP* Adapter with Internal Lock Installation

The lock can be mounted on the rail in a locked or unlocked orientation. One side of the lock includes a locking key. When the lock is installed with the key facing down into the OCP rail, the OCP card is securely held in place. The following figure shows the features of the lock.

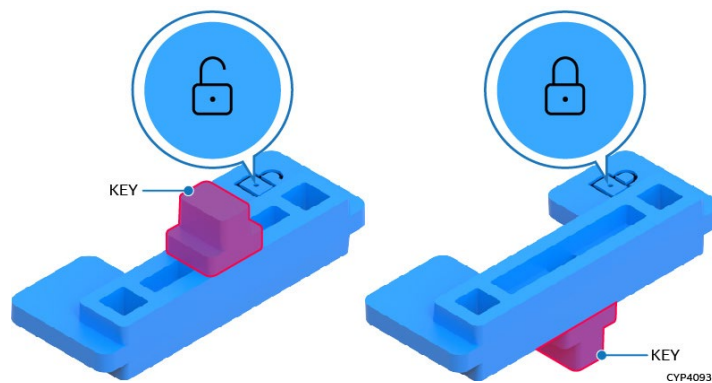

Figure 44. Internal Lock with Unlock and Lock Orientation

6. System Storage

The Intel® Server System M50FCP1UR has support for many data storage configuration options, including:

- Hot swap capable front drive bays with support for SATA, SAS, and NVMe* drives
- Two internal M.2 SSD connectors
- Native support for both SATA and NVMe storage interfaces

This chapter provides an overview for each.

Additional Intel® VROC NVMe and Intel® VROC SATA capabilities are available. The Intel® Server System M50FCP1UR supports Intel® VROC 8.0.

Note: The rules and operations for Intel® VROC NVMe* and Intel® VROC SATA are different from previous generation server systems. The rules and operations are discussed in this chapter.

6.1 Front Drive Bay Support

The Intel® Server System M50FCP1UR supports the following front drive bay options

- Up to four hot swap 2.5" – iPC M50FCP1UR204
- Up to twelve hot swap 2.5" – iPC M50FCP1UR212

All front drive bays support the following:

- Hot swap capable
- 2.5" SSDs
- Support for 7mm or 15mm height drives
- SAS / SATA / NVMe



Figure 45. 4 x 2.5" Front Drive Bay Configuration – M50FCP1UR204



Figure 46. 12 x 2.5" Front Drive Bay Configuration – M50FCP1UR212

Note: Drive numbering in the system illustrations is for general reference only. Actual drive numbering is dependent on the data source and how they are cabled to the backplane.

All drives in the front drive bay are mounted to an integrated drive rail.

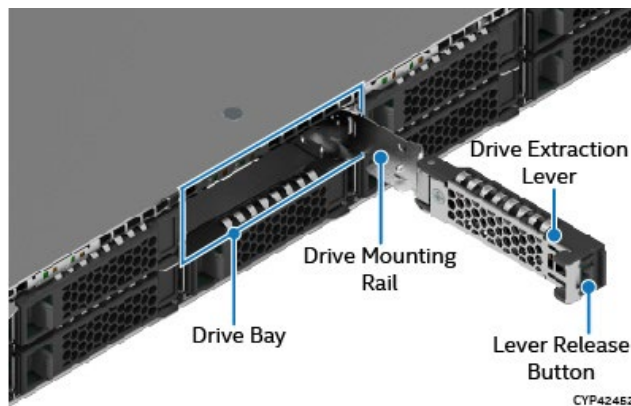

Figure 47. 2.5" Drive Bay Components

The integrated drive rail does not detach from the drive bay. When the drive extraction lever is release and in the open position, it is used to pull out the rail just enough to allow an SSD to be installed or removed from the drive bay. No tools are necessary to service a drive.

In support of system air flow and thermal management guidelines, all front drive bays must be populated with a drive or supplied drive blank. A drive blank should only be removed from the drive bay when replaced by an SSD.

All front drive bays support 2.5" SSDs with a height of 7mm or 15mm. However, to support a 7mm SSD, the two halves of a drive blank must be separated with one side then repurposed as an SSD mounting bracket.

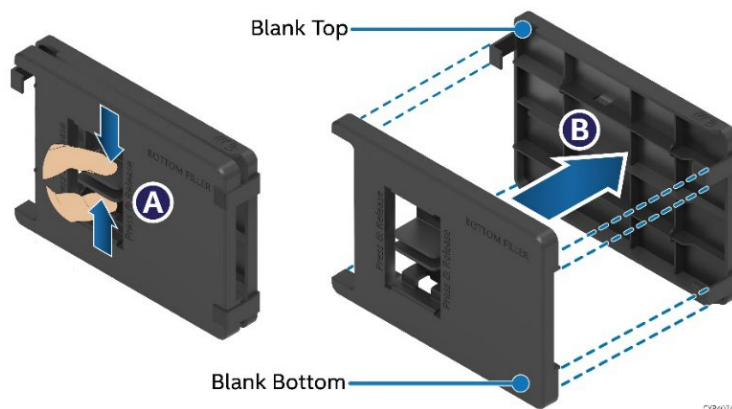

Figure 48. Separating a drive blank

With the drive blank separated, the side without the latch is then attached to the 7mm SSD.

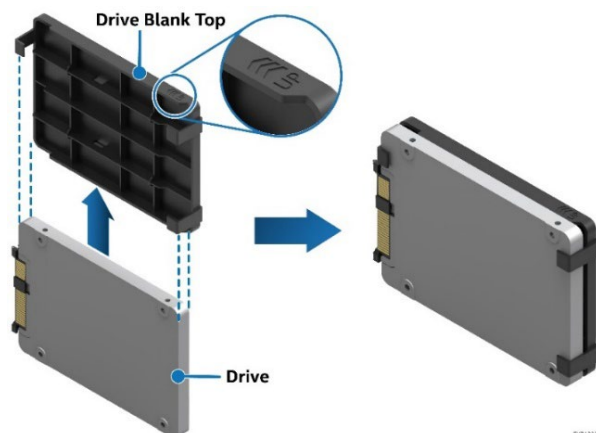

Figure 49. 7mm SSD Support

With the SSD mounting bracket attached to the 7mm drive, installation into the front drive bay is the same for both drive sizes. Note the location of the drive interface connector before installing the drive into the drive bay. Ensure its orientation matches with the interface connector on the backplane.

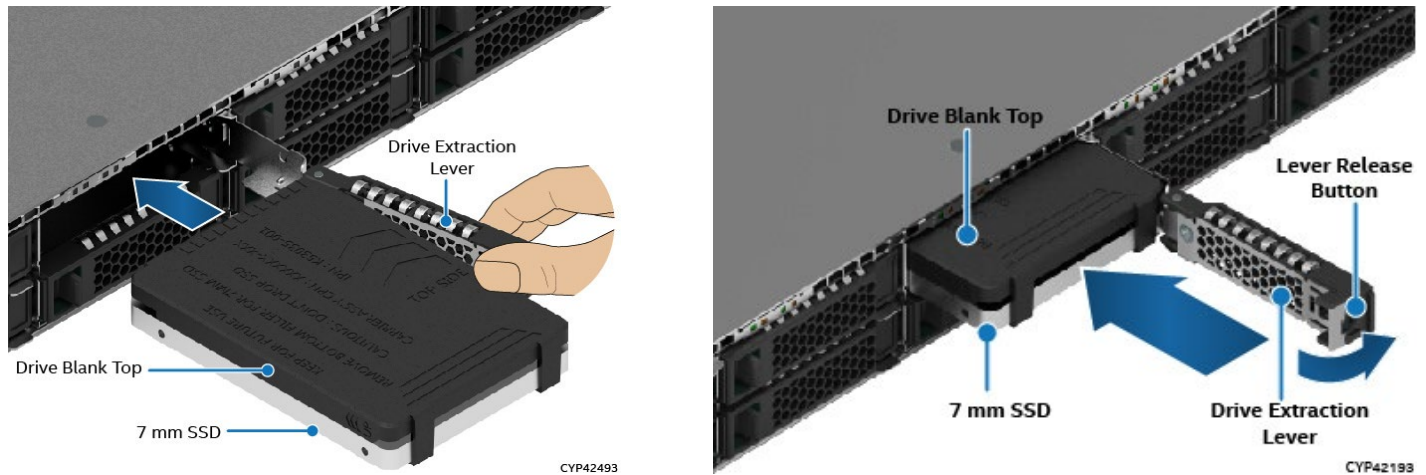

Figure 50. Drive Installation



Figure 51. Drive Removal from Drive Bay

6.1.1 Front Drive Bay LED Support

Each drive bay includes two LED indicators, green for drive activity and amber for drive status. Light pipes integrated into the chassis direct light emitted from LEDs mounted next to each drive connector on the backplane to the drive front bay. The pipes make the LEDs visible from the front of the system.

LEDs for two drives are mounted side-by-side on the top edge of the drive bay. The pair of LEDs on the left are for the top drive bay, and the pair of LEDs on the right is for the bottom drive bay (See Figure 52).

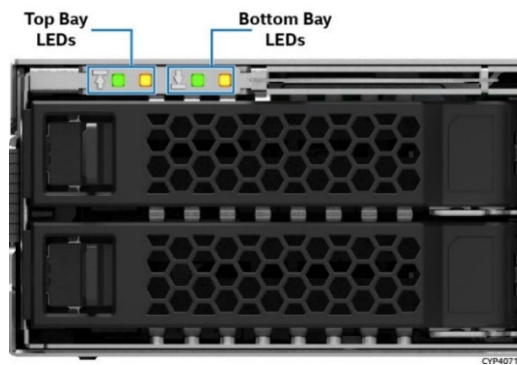

Figure 52. Drive Bay LED Identification

The following tables provide the LED states for each LED.

Table 17. Drive Status LED States

	LED State	Drive Status
Amber	Off	No access and no fault
	Solid on	Hard drive fault has occurred
	1 Hz blinking	RAID rebuild in progress
	2 Hz blinking	Locate (identify)

Table 18. Drive Activity LED States

	Condition	Drive Type	LED Behavior
Green	Power on with no drive activity	SAS/NVMe	LED stays on
		SATA	LED stays off
	Power on with drive activity	SAS/NVMe	LED blinks off when processing a command
		SATA	LED blinks on when processing a command
	Power on and drive spun down	SAS/NVMe	LED stays off
		SATA	LED stays off
	Power on and drive spinning up	SAS/NVMe	LED blinks
		SATA	LED stays off

Note: The drive activity LED is driven by signals from the drive itself. Drive vendors may choose to operate the activity LED different from what is described in Table 18. If the activity LED on a given drive type behaves differently than what is described, customers should reference the drive vendor specifications for the specific drive model to determine the expected drive activity LED operation.

6.2 Hot Swap Backplane (HSBP) Overview

The server system supports the following backplane options:

- 4 x 2.5" drive combo backplane with support for SAS/SATA/NVMe SSD drives
- 12 x 2.5" drive combo backplane with support for SAS/SATA/NVMe SSD drives

The backplanes are mounted to the back of the drive bay within the chassis as shown in the following figures.

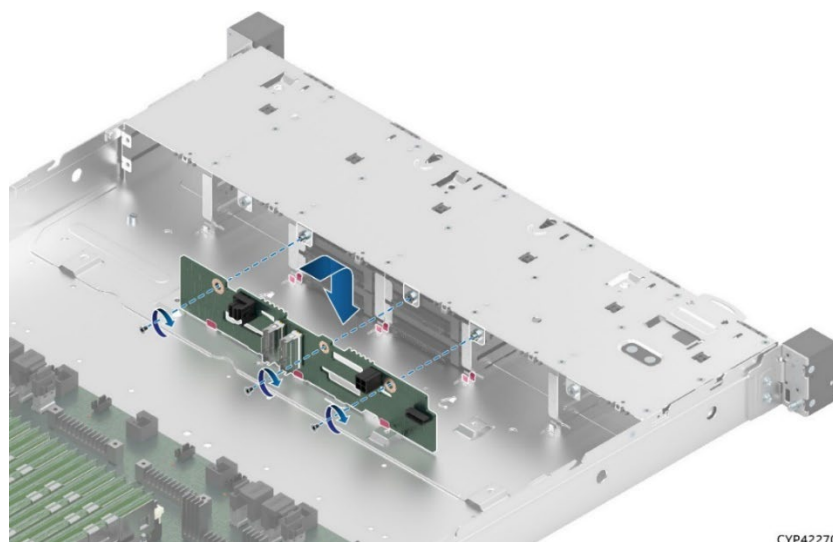

CYP42270

Figure 53. 4 x 2.5" Hot Swap Backplane Placement

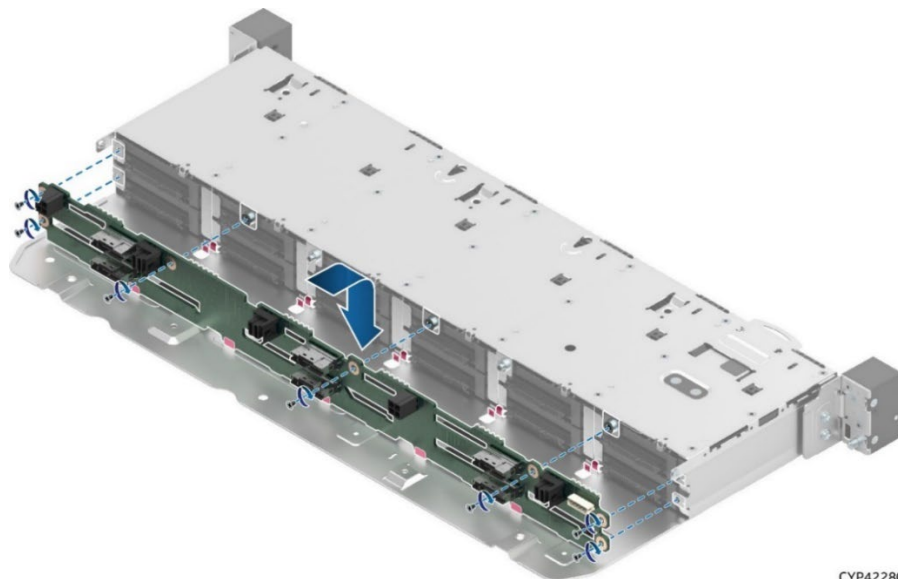

CYP42280

Figure 54. 12 x 2.5" Hot Swap Backplane Placement

Backplanes include the following features:

- Up to 22.5 Gb SAS and up to 6 Gb SATA
- 64 Gb/s PCIe NVMe
- Drive interface connectors
 - 68-pin SFF-8639: SATA/SAS/NVMe
- Hot swap capable
- Cable connectors
 - SFF-8643 Mini-SAS HD: 22.5 Gb SAS capable
 - PCIe SlimSAS connector
 - 1x5-pin connector: I²C interface for device status communication to the BMC over secondary SMBus
 - 2x2-pin connector: power
- SGPIO SFF-8485 interface embedded within the sideband of the Mini-SAS HD connectors
- HSBP microcontroller: Cypress* CY8C22545-24AXI PSoC* (Programmable System-on-Chip*) device
- LEDs to indicate drive activity and status for each attached device
- Device presence detects inputs to the microcontroller
- 5 V voltage regulator (VR) for devices
- 3.3 V voltage regulator (VR) for microcontroller
- Microcontroller firmware updateable over the I²C interface
- FRU EEPROM support
- Temperature sensor using a TMP75 (or equivalent) thermistor implementation with the microcontroller

6.2.1 SGPIO Functionality

Backplanes include support for an SFF-8485 compliant SGPIO interface used to activate the status LED. This interface is also monitored by the microcontroller for changing values of FAULT, IDENTIFY, and REBUILD registers. These items, in turn, are monitored by the server board BMC for generating corresponding System Event Log (SEL) events.

6.2.2 I²C Functionality

The microcontroller has a host/target I²C connection to the server board BMC. The microcontroller is not an Intelligent Platform Management Bus (IPMB) compliant device. The BMC generates SEL events by monitoring registers on the HSBP microcontroller for DRIVE PRESENCE, FAULT, and RAID REBUILD in progress.

The backplanes include one 1x5 pin cable connector used as a management interface between the server board and the installed backplane.

Table 19. I²C Cable Connector Pinout

Pin #	Signal Name
1	SMB_3V3_DAT
2	GND
3	SMB_3V3_CLK
4	SMB_ADD0
5	SMB_ADD1

6.2.3 Power Supply Connector

The backplanes include a 2x2 pin connector supplying power to the backplane.

Table 20. Power Connector Pinout

Pin #	Signal Name
1	GND
2	GND
3	P12V
4	P12V

Power for all backplanes is drawn from the power connector on the server board labeled “HSBP_PWR”. Appropriate power cables to support the backplane are included with the system and the backplane accessory kit.

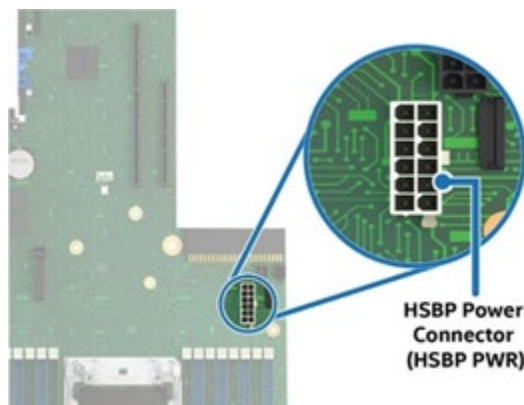

Figure 55. Server Board HSBP Power Connector

6.2.4 4 x 2.5" Drive SATA/SAS/NVMe* Combo Backplane (iPC CYPHSBP1204).

The 4 x 2.5" drive combo backplane supports different drive configurations. These configurations include SAS or SATA only, NVMe only, or a combination of both SAS and NVMe drives.

The front side of the backplane includes four 68-pin SFF-8639 drive interface (U.2) connectors, each capable of supporting one SAS, SATA, or NVMe drive. The connectors are labeled SSD_0, SSD_1, SSD_2, and SSD_3.

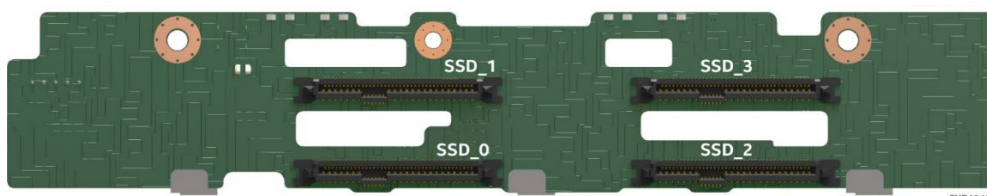

Figure 56. 4 x 2.5" SAS/SATA/NVMe* Hot Swap Backplane – Front Side

To support both SATA/SAS data signals and PCIe Bus lanes for NVMe drives, the backside of the backplane must include different types of cable connectors; Mini-SAS HD for SATA/SAS, and SlimSAS for NVMe.

In support of SATA/SAS drives, the backside of the backplane includes one 4-port Mini-SAS HD cable connector. The connector provides SATA/SAS data signals to four drive connectors on the frontside of the backplane. This cable connector is labeled “**SAS/SATA Port 0–3**”. Input cables can be routed from matching connectors on the server board (onboard SATA only), or from installed add-in SAS/SATA RAID cards.

In support of PCIe NVMe drives, the backside of the backplane includes two SlimSAS cable connectors. Each cable connector supports x8 PCIe bus lanes in support of two drive connectors on the frontside of the backplane. The SlimSAS connectors are labeled “**PCIe SSD 0–1**” and “**PCIe SSD 2–3**”. Each NVMe drive connected to the frontside of the backplane is supported by x4 PCIe bus lanes. PCIe bus lanes to the backplane can be routed from any of the following sources:

- Available server board PCIe MCIO connectors
- Optional tri-mode RAID add-in card

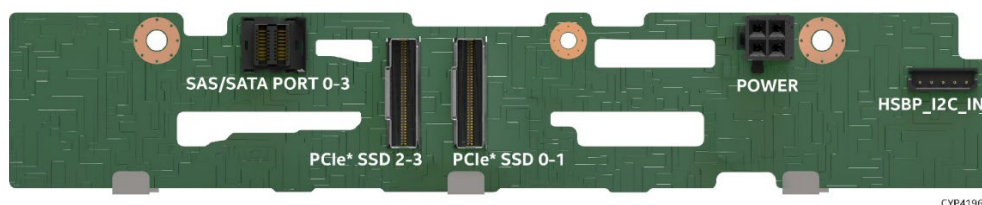

Figure 57. 4 x 2.5" SAS/SATA/NVMe* Hot Swap Backplane – Back Side

6.2.5 12 x 2.5" Drive SATA/SAS/NVMe* Combo Backplane

This section applies to the 12 x 2.5" drive SAS/SATA/NVMe combo backplane (iPC **CYPHSBP1212**).

The 12 x 2.5" drive combo backplane supports different drive configurations. These include SAS or SATA only, NVMe only, or a combination of both SAS and NVMe drives.

The front side of the backplane includes twelve 68-pin SFF-8639 drive interface (U.2) connectors, each capable of supporting one SAS, SATA, or NVMe drive. The connectors are labeled “**SSD_0**” through “**SSD_11**”.

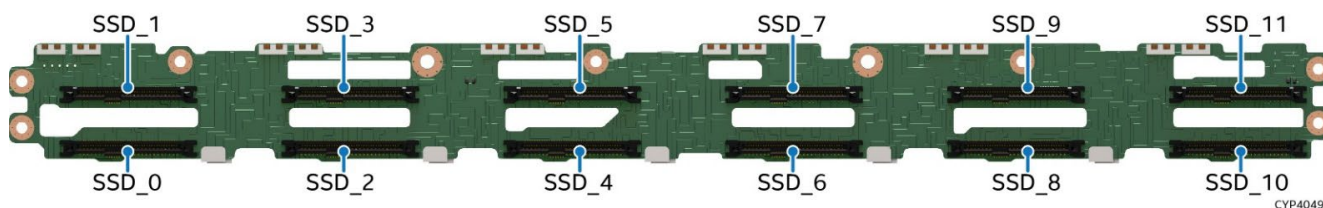

Figure 58. 12 x 2.5" SAS/SATA/NVMe* Hot Swap Backplane – Front Side

To support both SATA/SAS data signals and PCIe Bus lanes for NVMe drives, the backside of the backplane must include different types of cable connectors; Mini-SAS HD for SATA/SAS, and SlimSAS for NVMe.

In support of SATA/SAS drives, the backside of the backplane includes three 4-port Mini-SAS HD cable connectors. Each connector provides SATA/SAS data signals to four drive connectors on the frontside of the backplane. These cable connectors are labeled “**SAS/SATA Port 0–3**”, “**SAS/SATA Port 4–7**”, and “**SAS/SATA Port 8–11**”. Input cables can be routed from matching connectors on the server board (onboard SATA only), or from installed add-in SAS/SATA controller cards for drive configurations of greater than eight drives.

In support of PCIe NVMe drives, the backside of the backplane includes six SlimSAS cable connectors. Each cable connector supports X8 PCIe bus lanes in support of two drive connectors on the frontside of the backplane. The SlimSAS connectors are labeled “**PCIe SSD 0–1**” “**PCIe SSD 10–11**”. Each NVMe drive

connected to the frontside of the backplane is supported by X4 PCIe bus lanes. PCIe bus lanes to the backplane can be routed from any of the following sources:

- Available server board PCIe MCIO connectors
- Optional tri-mode RAID add-in card

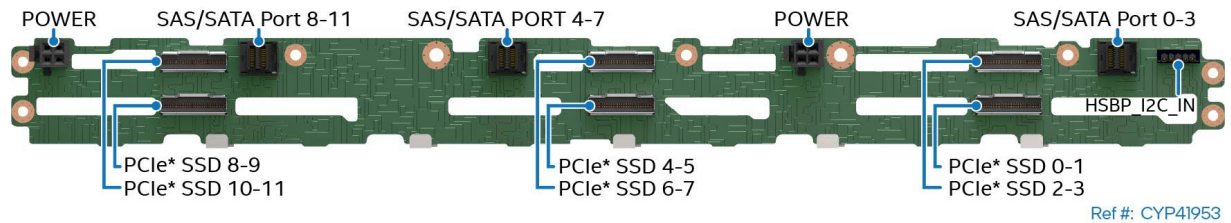

Figure 59. 12 x 2.5" SAS/SATA/NVMe* Hot Swap Backplane – Back Side

6.3 NVMe* Storage Support

Depending on the front drive bay option, the Intel® Server System M50FCP1U can support up to four or up to twelve 64Gb/sec PCIe* NVMe* solid state drives (SSD). Each installed NVMe drive is supported by X4 PCIe bus lanes.

6.3.1 PCIe* Mini Cool Edge IO (MCIO*) Connector Support

The server board includes sixteen PCIe Mini Cool Edge IO (MCIO*) cable connectors. MCIO is a next generation ultra-high-speed interconnect solution for server boards and storage devices. Each MCIO cable connector supplies X4 PCIe bus lanes for a PCIe NVMe drive when cabled to a backplane.

X32 PCIe bus lanes from each installed processor are routed to a set of eight PCIe MCIO connectors (See Figure 30). On the server board each MCIO connector is label according to the processor supplying the PCIe bus lanes, and the PCIe port from the specified processor (See Figure 60).

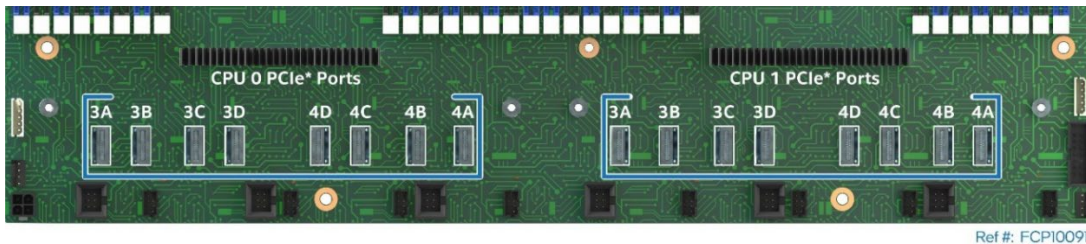

Figure 60. PCIe* MCIO Connectors

6.3.2 Intel® Volume Management Device (Intel® VMD) 3.0 for NVMe*

Intel® Volume Management Device (Intel® VMD) is hardware logic inside the processor root complex to help manage PCIe NVMe SSDs. Intel® VMD provides robust hot plug support and status LED management. This capability allows servicing of storage system NVMe SSD media without concern of system crashes or hangs when ejecting or inserting NVMe SSD devices on the PCIe bus.

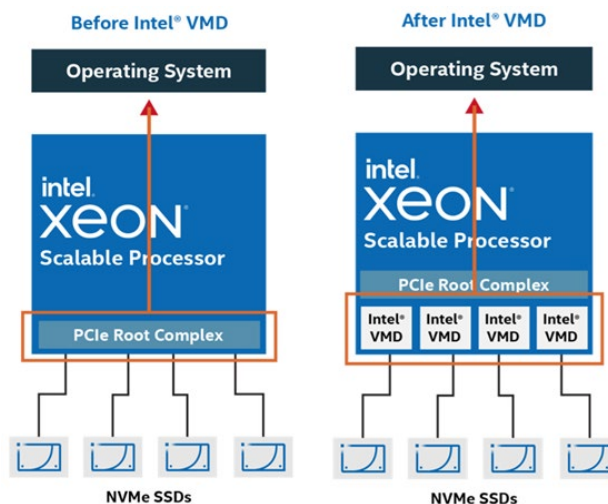

Figure 61. NVMe* Storage Bus Event / Error Handling

Intel® VMD handles the physical management of NVMe storage devices as a stand-alone function but can be enhanced when Intel® Virtual RAID on CPU (Intel® VROC) support options are enabled to implement RAID-based storage systems.

Intel® VMD 3.0 includes the following features and capabilities:

- Hardware is integrated inside the processor PCIe root complex.
- Entire PCIe trees are mapped into their own address spaces (domains).
- Each domain manages x16 PCIe lanes.
- Can be enabled/disabled through the <F2> BIOS setup utility at x4 lane granularity.
- OS Embedded driver sets up/manages the domain (enumerate, event/error handling).
- Hot plug support - hot insert array of PCIe NVMe SSDs.
- Support for PCIe NVMe SSDs only. No network interface controllers (NICs), graphics cards, etc.
- Maximum of 128 PCIe bus numbers per domain.
- Support for Management Component Transport Protocol (MCTP) over SMBus only.
- Support for MMIO only (no port mapped I/O).
- Does not support NTB, Intel® QuickData Technology, Intel® Omni-Path Architecture (Intel® OPA), or SR-IOV.
- Correctable errors do not bring down the system.
- Intel VMD only manages devices on PCIe lanes routed directly from the processor or chipset PCH.
- When Intel VMD is enabled, the BIOS does not enumerate devices that are behind VMD. The OS embedded Intel VMD-enabled driver is responsible for enumerating these devices and exposing them to the host.

6.3.2.1 Enabling Intel® VMD for NVMe* Support

For installed NVMe devices to use the Intel VMD features in the system, Intel VMD must be enabled on the appropriate processor PCIe root ports in the <F2> BIOS setup utility. By default, Intel VMD support is disabled on all processor PCIe* root ports. To enable Intel VMD support on the appropriate CPU PCIe root port, navigate to **Advanced > PCI Configuration > Volume Management Device** in the <F2> BIOS Setup menu.

Note: PCIe root ports should only be enabled for PCIe MCIO connectors supporting NVMe devices. PCIe root ports supporting other Non-NVMe PCIe devices should remain in their default disabled setting.

The following table provides the PCIe port routing information for the server board PCIe MCIO connectors.

Table 21. CPU to PCIe* NVMe* MCIO Connector Routing

Host	CPU Port	Routed to MCIO Connector
CPU 0	Port 3A	CPU0_PClE_Port3A
	Port 3B	CPU0_PClE_Port3B
	Port 3C	CPU0_PClE_Port3C
	Port 3D	CPU0_PClE_Port3D
	Port 4D	CPU0_PClE_Port4D
	Port 4C	CPU0_PClE_Port4C
	Port 4B	CPU0_PClE_Port4B
	Port 4A	CPU0_PClE_Port4A
CPU 1	Port 3A	CPU1_PClE_Port3A
	Port 3B	CPU1_PClE_Port3B
	Port 3C	CPU1_PClE_Port3C
	Port 3D	CPU1_PClE_Port3D
	Port 4D	CPU1_PClE_Port4D
	Port 4C	CPU1_PClE_Port4C
	Port 4B	CPU1_PClE_Port4B
	Port 4A	CPU1_PClE_Port4A

6.3.3 Intel® Virtual RAID on CPU for NVMe (Intel® VROC for NVMe) 8.0

The Intel® Server M50FCP family uses embedded Intel® Virtual RAID on CPU for NVMe (Intel® VROC for NVMe) 8.0 technology to provide RAID support for both Intel and non-Intel NVMe SSDs interfaced through the onboard PCIe MCIO connectors.

Intel® VROC for NVMe is an enterprise RAID solution that unleashes the performance of NVMe SSDs. Intel® VROC is enabled by a feature embedded within Intel® Xeon® Scalable processors called Intel® Volume Management Device (Intel® VMD), an integrated controller inside the CPU PCIe root complex. NVMe SSDs interfaced using any of the onboard PCIe MCIO connectors are directly supported by the CPU, allowing the full performance potential of fast storage devices to be realized.

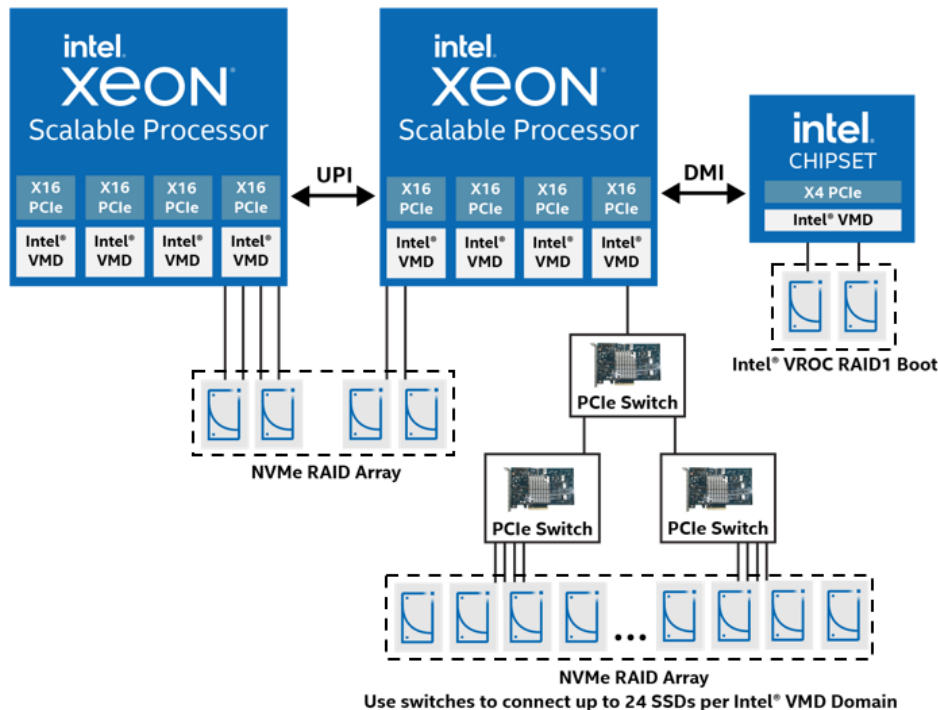

Figure 62. Supported NVMe* Configurations – Windows* and Linux*

Intel® VROC is a complete RAID solution, including:

- High performance due to direct connect of SSDs
- Platform integrated storage controller functions provided by Intel® VMD
- Boot and Data RAID
- Scalable to many devices and RAID arrays
- Support for SATA, Intel® VMD NVMe RAID, and non-Intel® VMD NVMe RAID

Intel® VROC for NVMe is an optional feature and must be activated before it can be used for NVMe RAID configurations.

Intel offers two Intel® VROC for NVMe License Activation key options, Standard and Premium. See [Table 22](#) for option details.

An Intel® VROC for NVMe License Activation key is a software key that can be pre-loaded onto the system by Intel when ordering a fully integrated L9 server system using Intel's online Configure-to-Order (CTO) tool, or it can be purchased separately from the system and installed later using the system's Integrated BMC Web Console, Redfish* API, or the Intel® Server Configuration utility. Full installation instructions are provided when the activation license key is ordered separately.

Note: See [Appendix B Software License Key Order, Registration, and Installation](#) for more information.

Supported features for available Intel® VROC for NVMe License Activation keys are shown in the following table.

Table 22. Intel® VROC for NVMe Activation License Key – Supported NVMe* RAID Features

NVMe* RAID Major Features	Standard Intel® VROC Key (iPC VROCSTANKEY)	Premium Intel® VROC Key (iPC VROCPREMKEY)
Processor-attached NVMe* SSD: high performance	Yes	Yes
Bootable on RAID volume	Yes	Yes
Third party vendor SSD support	Yes	Yes
RAID 0/1/10	Yes	Yes
RAID 5	No	Yes
RAID write hole closed (RMFBU replacement)	No	Yes
Hot plug/ surprise removal (2.5" SSD form factor only)	Yes	Yes
Enclosure LED management	Yes	Yes

6.3.4 NVMe* Drive Population Rules for Intel® VROC 8.0

Specific drive population rules must be followed to support NVMe RAID 1/5/10. These rules are dependent on how the NVMe drives in the front bay are cabled to the PCIe sources through the backplane. The backplanes support PCIe interfaces from various PCIe sources through x8 SlimSAS connectors. The NVMe population rules are described in this section.

The backplane supports PCIe interfaces from the following sources:

- Server board PCIe MCIO connectors
- Optional tri-mode Intel® RAID add-in cards

Only NVMe drives cabled to PCIe sources routed to the same PCIe root port of a given processor can be configured into a bootable RAID volume (see [Table 12](#)).

6.3.4.1 Server Board PCIe* MCIO Connectors and/or PCIe* NVMe* Riser Cards and/or Tri-Mode Intel® RAID Module to 4 x 2.5" Combo Backplane

When cabling a PCIe interface source to the backplane, the cable must be connected only to the drive set highlighted in the following figure. This backplane does not support PCIe interfaces from multiple PCIe sources for RAID 1/5/10 enablement. Combining an NVMe drive with a SAS/SATA drive within a defined drive set is not supported.

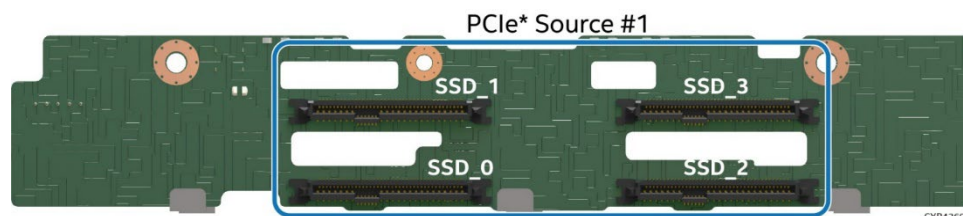

Figure 63. 4 x 2.5" SAS/SATA/NVMe* Hot Swap Backplane – Front side

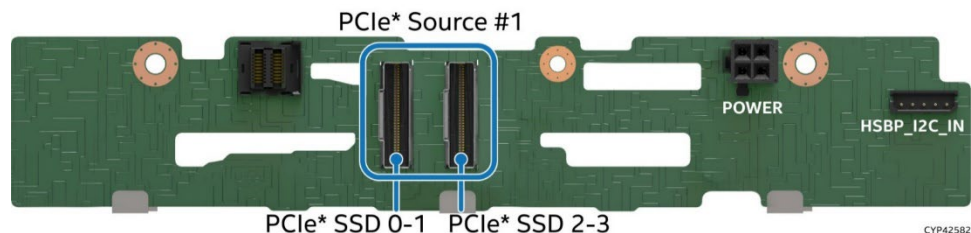

Figure 64. 4 x 2.5" SAS/SATA/NVMe* Hot Swap Backplane – Back Side

6.3.4.2 Server Board PCIe* MCIO Connectors and/or PCIe* NVMe* Riser Cards and/or Tri-Mode Intel® RAID Module to 12 x 2.5" Combo Backplane

When cabling the PCIe interfaces from two different sources to the backplane, the cables from each source must be connected in defined drive sets of four, (0-3) or (4-7) or (8-11), as shown in the following figure.

When cabling the backplane from multiple PCIe sources, no other drive set combinations beyond the following defined combinations are supported. Combining an NVMe drive with a SAS/SATA drive within a defined drive set is not supported.

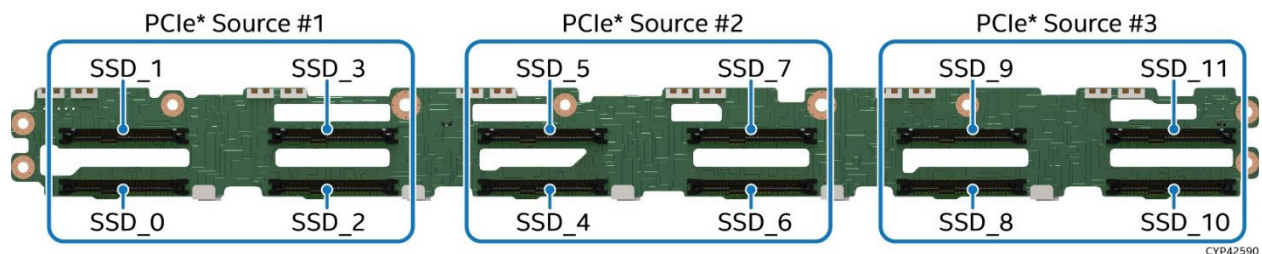

Figure 65. 12 x 2.5" SAS/SATA/NVMe* Hot Swap Backplane – Front Side

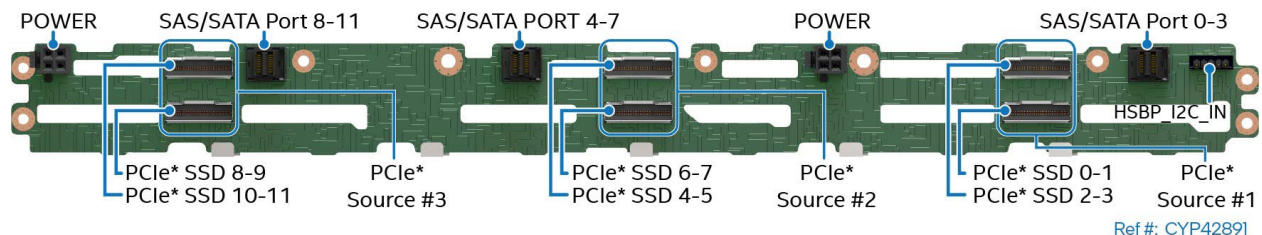

Figure 66. 12 x 2.5" SAS/SATA/NVMe* Hot Swap Backplane – Back Side

6.4 Server Board SATA Support

SATA drives are supported by two Intel chipset embedded AHCI SATA controllers, identified as “SATA_0” and “SATA_1”. Each SATA controller supports 6 GB/s SATA 3.0 ports. SATA ports from each controller are routed to connectors on the server board as follows:

- SATA_0 ports 0–3 are routed to one SFF-8643 Mini-SAS HD cable connector
- SATA_1 ports 0–3 are routed to one SDD-8643 Mini-SAS HD cable connector
- SATA_1 ports 4 and 6 are routed to two M.2 SSD connectors

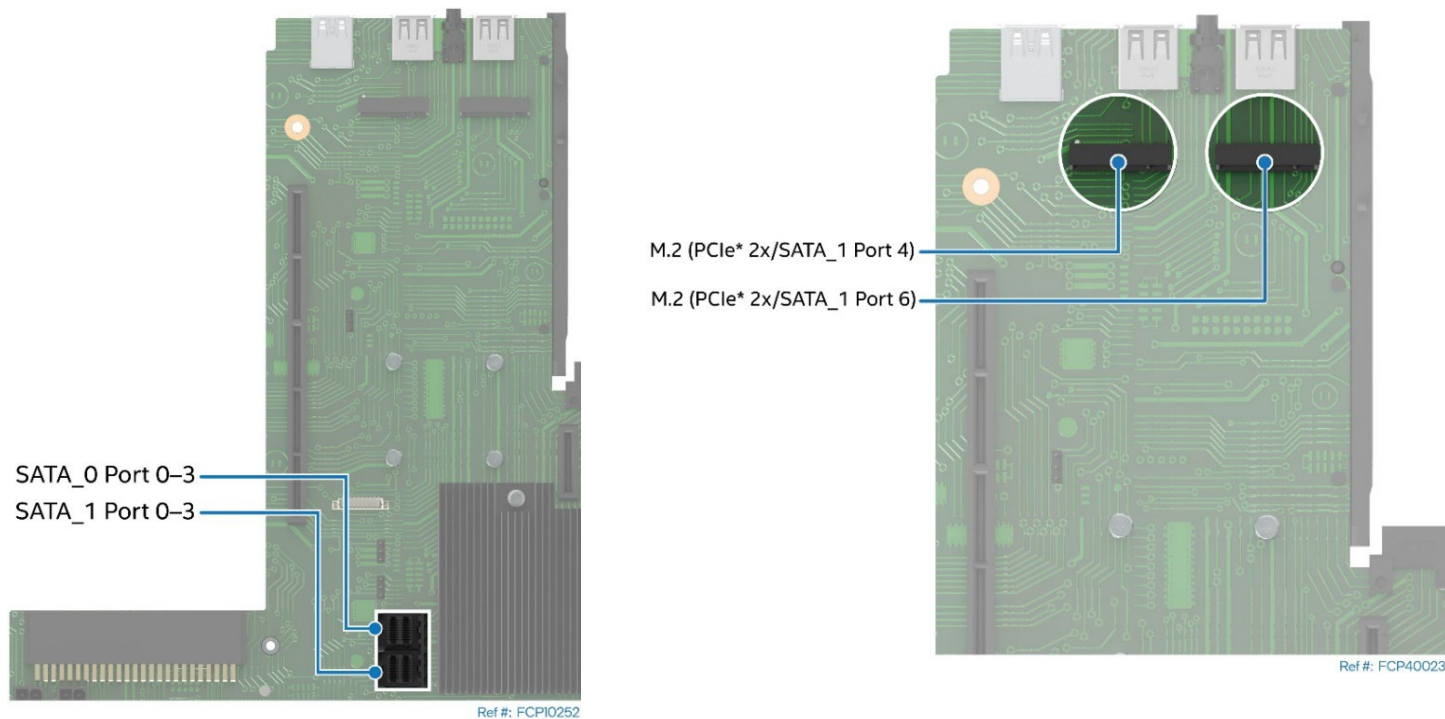

Figure 67. Onboard SATA Cable Connectors and M.2 SSD Connectors

The following table describes the SATA_0 and SATA_1 controller feature support.

Table 23. SATA_0 and SATA_1 Controller Feature Support

Feature	Description	AHCI Mode	RAID Mode Intel® VROC (SATA RAID)
Native Command Queuing (NCQ)	Allows the device to reorder commands for more efficient data transfers	Supported	Supported
Auto Activate for direct memory access (DMA)	Collapses a DMA Setup, then DMA Activate sequence into a DMA Setup only	Supported	Supported
Hot Plug Support (U.2 Drives Only)	Allows for device detection without power being applied and ability to connect and disconnect devices without prior notification to the system	Supported	Supported
Asynchronous Signal Recovery	Provides a recovery from a loss of signal or establishing communication after hot plug	Supported	Supported
6 Gb/s Transfer Rate	Capable of data transfers up to 6 Gb/s	Supported	Supported
ATAPI Asynchronous Notification	A mechanism for a device to send a notification to the host that the device requires attention	Supported	Supported
Host and Link Initiated Power Management	Capability for the host controller or device to request Partial and Slumber interface power states	Supported	Supported
Staggered Spin-Up	Enables the host the ability to spin up hard drives sequentially to prevent power load problems on boot	Supported	Supported
Command Completion Coalescing	Reduces interrupt and completion overhead by allowing a specified number of commands to complete and then generating an interrupt to process the commands	Supported	N/A

The SATA_0 controller and the SATA_1 controller can be independently configured using the <F2> BIOS setup utility to function in AHCI mode or disabled.

6.4.1 Staggered Disk Spin-Up

A high number of hard drives with spinning media can be attached to the onboard SATA controllers. The combined startup power demand for all attached hard drives can be much higher than the normal running power requirements.

To mitigate the condition and lessen the peak power demand during system startup, both the AHCI SATA controllers implement a Staggered Spin-Up capability for the attached drives. This means that the drives are started up separately, with a certain delay between disk drives starting.

To enable staggered spin-up, go to BIOS setup utility >Mass Storage Controller Configuration screen > **AHCI HDD Staggered Spin-Up**.

6.4.2 Intel® Virtual RAID on CPU SATA 8.0 (Intel® VROC SATA)

Intel® VROC SATA provides an embedded enterprise RAID solution for SATA devices connected to the SATA controllers of the Intel® Platform Control Hub (PCH).

By default, onboard RAID options are disabled in BIOS Setup. To enable them, access the BIOS Setup utility by pressing <F2> key during POST. Navigate to the onboard RAID configuration menu: **Advanced > Mass Storage Controller Configuration > sSATA Controller or SATA Controller**.

From the options available in the menu, select the “RAID” mode to enable the RAID support.

Note: RAID partitions created using Intel® VROC 8.0 cannot span across the two embedded SATA controllers. Only drives attached to a common SATA controller can be included in a RAID partition

Supported SATA RAID levels include RAID 0, RAID 1, RAID 5, and RAID 10

- **RAID 0 (striping)** – RAID level 0 combines at least two (up to the maximum number) drives supported by the embedded SATA and sSATA controllers, so that all data is divided into manageable blocks called strips. The strips are distributed across the array members on which the RAID 0 volume resides. Data stored in a RAID 0 volume is not redundant. Therefore, if one drive fails, all data on the volume is lost.
- **RAID 1 (mirroring)** – Data is concurrently written to two drives creating real-time redundancy of all data written to the first drive. This condition is good for small databases or other applications that require small capacity but complete data redundancy. The maximum number of drives supported in a RAID 1 volume is two drives. The RAID 1 volume appears as a single physical drive with a capacity equal to that of the smaller drive.
- **RAID 5 (striping with parity)** – A RAID 5 volume provides the capacity of $(N - 1) \times$ smallest size of the drives, where $N \geq 3$ and \leq maximum number of drives supported by the SATA or sSATA controller. All data is divided into manageable blocks called strips. RAID 5 also stores parity, a mathematical method for recreating lost data on a single drive. The data and parity are striped across array members. Because of parity, it is possible to rebuild the data after replacing a failed drive with a new one. The maximum number of drives supported in a RAID 5 is the maximum number of drives supported by the platform.
- **RAID 10 (striping and mirroring)** – RAID level 10 uses four drives to create a combination of RAID levels 0 and 1. The data is striped across a two-disk array forming a RAID 0 component. Each of the drives in the RAID 0 array is mirrored to form a RAID 1 component. This condition provides the performance benefits of RAID 0 and the redundancy of RAID 1. The RAID 10 volume appears as a single physical drive with a capacity equal to the two smallest drives of the four-drive configuration. The space on the remaining two drives will be used for mirroring. The maximum number of drives supported in a RAID 10 is four. By using Intel® VROC 8.0, there is no loss of PCIe resources or add-in card slot.

Intel® VROC 8.0 functionality requires the following:

- The embedded RAID option must be enabled in BIOS setup utility.
- Intel® VROC 8.0 option must be selected in BIOS setup utility.
- Intel® VROC 8.0 drivers must be loaded for the installed operating system.
- Up to 16 SATA drives Two SATA drives needed to support RAID levels 1.
- At least three SATA drives needed to support RAID level 5.
- Up to four SATA drives needed to support RAID level 10.
- NVMe SSDs and SATA drives must not be mixed within a single RAID volume.

With Intel® VROC 8.0 software RAID enabled, the following features are made available:

- A boot-time, pre-operating-system environment, text-mode user interface that allows the user to manage the RAID configuration in the system. Its feature set is kept simple to keep its size to a minimum. The user is allowed to create and delete RAID volumes and select recovery options when problems occur. The user interface can be accessed by pressing **<CTRL-I>** during system POST.
- At each boot-up, a status of the RAID volumes provided to the user.

6.5 SAS Storage Support

The server system supports front bay SAS/SATA drives using add-cards connected to riser cards. For more information on supported add-in cards, see the *Intel® Server M50FCP Family Configuration Guide*.

6.6 M.2 SSD Storage Support

The server board includes two M.2 SSD connectors as shown in [Figure 67](#). The connectors are labeled “**M2_x2PCIe/SATA_1 Port 4**” and “**M2_x2PCIe/SATA_1 Port 6**” on the board. Each M.2 slot supports a PCIe NVMe or SATA drive that conforms to a 22110 (110 mm) or 2280 (80 mm) form factor.

Each M.2 slot is connected to four PCIe 3.0 lanes from the chipset’s embedded controller. The M.2 NVMe drives can be combined into a VROC RAID volume.

7. Front Control Panel and I/O

This chapter provides information on the front Control Panel and I/O available on the front and rear of the server system.

7.1 Control Panel Features

The front Control Panel provides push button system controls and LED indicators for several system features.



Figure 68. Front Control Panel Features

- Power/Sleep Button w/Integrated LED:** Toggles the system power on and off. This button also functions as a sleep button if enabled by an ACPI compliant operating system. Pressing this button sends a signal to the integrated BMC that either powers on or powers off the system. The integrated LED is a single color (green) and supports different indicator states as defined in the following table.

Note: After source power is connected, several subsystems are initialized, and low-level FRU discovery is performed. This process can take up to 90 seconds. When this process is completed, the ID LED turns solid on, indicating that the system is ready to be powered on.

Table 24. Power / Sleep LED Functional States

Power Mode	LED	System State	Description
Non-ACPI	Off	Power-off	System power is off, and the BIOS has not initialized the chipset.
	On	Power-on	System power is on
ACPI	Off	S5	Mechanical is off and the operating system has not saved any context to peripheral storage
	On	S0	System and the operating system are up and running.

- System ID Button w/Integrated LED:** Toggles the integrated ID LED button in the front Control Panel and the integrated ID LED button on the back of the server board on and off. Both LEDs are tied together and show the same state. The onboard system ID LED is on the back edge of the server board, viewable from the back of the system. The system ID LEDs are used to identify the system for maintenance when installed in a rack of similar server systems. Two options available for illuminating the system ID LEDs are:
 - The front panel system ID LED button is pushed, causing the LEDs to illuminate to a solid On state until the button is pushed again.
 - An IPMI Chassis Identify command is remotely entered, causing the LEDs to blink for 15 seconds.
- NMI Button:** When the NMI button is pressed, it puts the server in a halt state and issues a non-maskable interrupt (NMI). This action can be useful when performing diagnostics for a given issue where a memory download is necessary to help determine the cause of the problem. To prevent an inadvertent system halt, the actual NMI button is behind the front Control Panel faceplate where it is only accessible with the use of a small-tipped tool like a pin or paper clip.

- System Cold Reset Button:** When pressed, this button reboots and reinitializes the system. Unlike the power button, the reset button does not disconnect the power to the system. It just starts the system's Power-On Self-Test (POST) sequence over again.
- Drive Activity LED:** The drive activity LED on the front panel indicates drive activity from the server board SATA and sATA storage controllers. The server board also has an I²C header labeled "SAS_MODULE_MISC" to provide access to this LED for add-in SATA or sATA storage controllers. See [Table 18](#) for SAS/SATA drive activity LED states.
- System Status LED:** The system status LED is a bicolor (green/amber) indicator that shows the current health of the server system. The system provides two locations for this feature; one is on the front Control Panel and the other is on the back edge of the server board, viewable from the back of the system. Both LEDs are tied together and show the same state. The system status LED states are driven by the server board platform management subsystem. When the server is powered down (transitions to the DC-Off state or S5), the BMC is still on standby power and retains the sensor and front panel status LED state established before the power-down event. The following table provides a description of each supported LED state.

Table 25. System Status LED State Definitions

LED State	System State	BIOS Status Description
Off	No AC Power to system	<ul style="list-style-type: none"> System power is not present. System is in EuP Lot6 off mode.
Solid green	System is operating normally.	<ul style="list-style-type: none"> System is in S5 soft-Off state. System is running (in S0 State) and its status is healthy. The system is not exhibiting any errors. Source power is present, BMC has booted, and manageability functionality is up and running. After a BMC reset, and in conjunction with the chassis ID solid on, the BMC is booting Linux*. Control has been passed from BMC U-Boot* to BMC Linux. The BMC is in this state for roughly 10–20 seconds.
Blinking green	System is operating in a degraded state although still functioning, or system is operating in a redundant state but with an impending failure warning.	<ul style="list-style-type: none"> Redundancy loss such as fan or power-supply (When Power Cold Redundancy is enabled). Applies only if the associated platform subsystem has redundancy capabilities. Fan warning or failure when the number of fully operational fans is less than the minimum number needed to cool the system. Non-critical threshold crossed: Temperature (including HSBP temp), voltage, input power to power supply, output current for main power rail from power supply and Processor Thermal Control (Therm Ctrl) sensors. Power supply predictive failure occurred while redundant power supply configuration was present. Unable to use all installed memory (more than 1 memory module installed). Correctable Errors over a threshold and migrating to a spare memory module (memory sparing). This indicates that the system no longer has spared memory module s (a redundancy lost condition). Corresponding memory LED lit. In mirrored configuration, when memory mirroring takes place and system loses memory redundancy. Battery failure. BMC executing in U-Boot. (Indicated by Chassis ID blinking at 3 Hz while Status blinking at 1 Hz). System in degraded state (no manageability). BMC U-Boot is running but has not transferred control to BMC Linux. Server will be in this state 6–8 seconds after BMC reset while it pulls the Linux image into flash. BMC Watchdog has reset the BMC. Power Unit sensor offset for configuration error is asserted. SSD Hot Swap Controller is off-line or degraded.
Blinking green and	System is initializing	

LED State	System State	BIOS Status Description
amber alternatively	after source power is applied	<ul style="list-style-type: none"> • PFR in the process of updating/authenticating/recovering when source power is connected, system firmware being updated. • System not ready to take power button event/signal.
Blinking amber	System is operating in a degraded state with an impending failure warning, although still functioning. System is likely to fail.	<ul style="list-style-type: none"> • Critical threshold crossed: Voltage, temperature (including HSBP temp), input power to power supply, output current for main power rail from power supply and PROCHOT (Therm Ctrl) sensors. • VRD Hot asserted. • Minimum number of fans to cool the system not present or failed. • Hard drive fault. • Power Unit Redundancy sensor: Insufficient resources offset (indicates not enough power supplies present). • In non-sparing and non-mirroring mode, if the threshold of correctable errors is crossed within the window. • Invalid firmware image detected during system boot or firmware update.
Solid amber	Critical/non-recoverable: system is halted. Fatal alarm: system has failed or shut down.	<ul style="list-style-type: none"> • Processor CATERR signal asserted. • MSID mismatch detected (CATERR also asserts for this case). • CPU 0 is missing. • Processor Thermal Trip. • No power good: power fault. • Memory module failure when there is only 1 memory module present and hence no good memory present. • Runtime memory uncorrectable error in non-redundant mode. • DIMM Thermal Trip or equivalent. • SSB Thermal Trip or equivalent. • Processor ERR2 signal asserted. • BMC/Video memory test failed. (Chassis ID shows blue/solid-on for this condition.) • Both U-Boot BMC firmware images are bad. (Chassis ID shows blue/solid-on for this condition.) • 240 VA fault. • Fatal Error in processor initialization: <ul style="list-style-type: none"> • Processor family not identical • Processor model not identical • Processor core/thread counts not identical • Processor cache size not identical • Unable to synchronize processor frequency • Unable to synchronize QPI link frequency • BMC fail authentication with non-recoverable condition, system hang at T-1; boot PCH only, system hang; PIT failed, system lockdown.

7.2 Front I/O Features

The front I/O provides two USB ports as shown in the following figure.

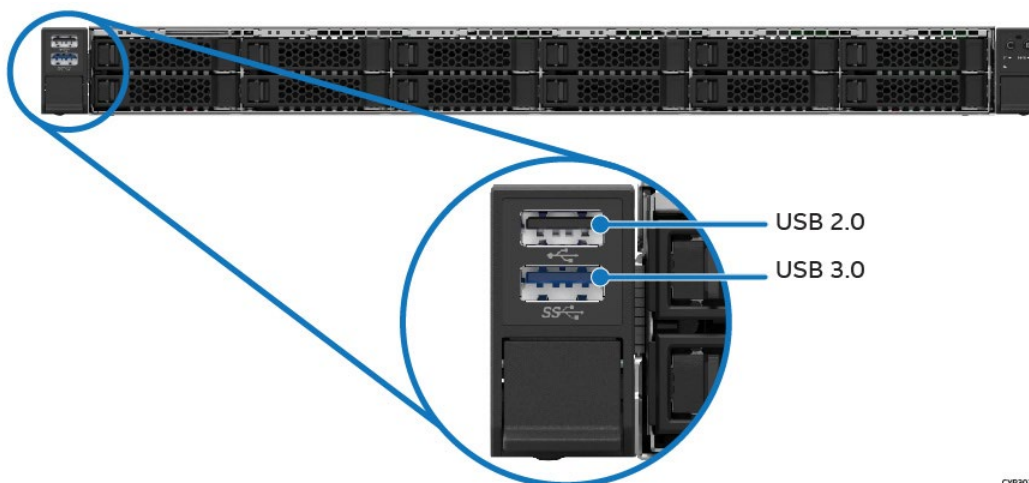

CVP30281

Figure 69. Front I/O Features

7.3 Rear I/O Features

The system rear I/O provides serial, video, and USB ports, an OCP adapter bay, and a dedicated management network port as shown in the following figure.

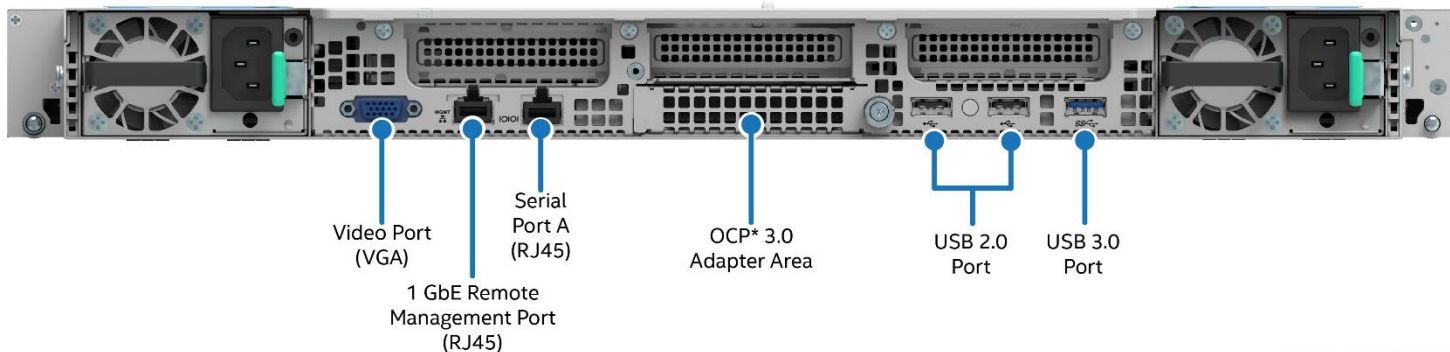

Ref #: FCP20062

Figure 70. Rear I/O Features

7.3.1 Remote Management Port

The server system includes a dedicated 1 GbE, RJ45 management port used for remote access to embedded system management features.

Note: This Ethernet port is dedicated for system management purposes only. It is not intended or designed to support standard LAN data traffic.



Ref #: FCP20072

Figure 71. Remote Management Port

The remote management port can be configured using the <F2> BIOS Setup Utility before it can be used for remote management purposes. See the *Intel® Server Board M50FCP2SBSTC TPS* for additional information.

7.3.2 Serial Port A Support

Serial Port A is an external RJ45 type connector on the back edge of the server board as shown in the following figure.



Figure 72. Serial Port A

The pin orientation is shown in [Figure 73](#) and the pinout is in [Table 26](#).

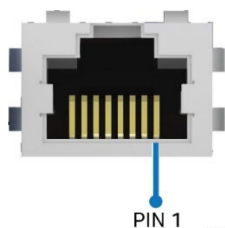

Figure 73. RJ45 Serial Port A Pin Orientation

Table 26. RJ45 Serial Port A Connector Pinout

Pin #	Signal Name	Pin #	Signal Name
1	RTS	5	RI
2	DTR	6	SIN
3	SOUT	7	DCD or DSR
4	GROUND	8	CTS

7.3.3 USB Support

The following figure shows the three rear USB ports. The USB 3.0 port is closest to the OCP module connector.



Figure 74. External USB 2.0 and 3.0 Connector Ports

7.3.4 Video Support

A standard 15-pin video connector is on the back edge of the server board.

7.3.4.1 Video Resolutions

The graphics controller in the Aspeed AST2600* BMC is a VGA-compliant controller with 2D hardware acceleration and full bus primary support. With 16 MB of memory reserved, the video controller supports the resolutions specified in the following table.

Table 27. Supported Video Resolutions

2D Mode Resolution	2D Video Mode Support (Color Bit)	
	16 bpp	32 bpp
640 x 480	60 Hz	60 Hz
800 x 600	60 Hz	60 Hz
1024 x 768	60 Hz	60 Hz
1280 x 800	60 Hz	60 Hz
1280 x 1024	60 Hz	60 Hz
1440 x 900	60 Hz	60 Hz
1680 x 1050	60 Hz	60 Hz
1920 x 1080	60 Hz	60 Hz

7.3.4.2 Server Board Video and add-in Video Adapter Support

The server board includes two options to attach a monitor to the server system:

- A standard 15-pin video connector on the back of the server system.
- Add-in video cards can be used to either replace or complement the server board video option.

The BIOS setup utility includes options to support the desired video operation when an add-in video card is installed.

- When both the **Onboard Video** and **add-in Video Adapter** options are set to **Enabled**, both video displays can be active. The onboard video is still the primary console and active during BIOS POST. The add-in video adapter is only active under an operating system environment with video driver support.

- When **Onboard Video** is **Enabled** and **add-in Video Adapter** is **Disabled**, only the onboard video is active.
- When **Onboard Video** is **Disabled** and **Add-In Video Adapter** is **Enabled**, only the add-in video adapter is active.

Configurations with add-in video cards can get more complicated with a dual processor server board. Some multi-socket server boards have PCIe slots capable of hosting an add-in video card that is attached to the IIOs of a processor other than processor 0. However, only one processor socket can be designated as a legacy VGA socket as required in POST. To provide for this situation, there is the PCI Configuration option **Legacy VGA Socket**. The rules for this option are:

- The **Legacy VGA Socket** option is grayed out and unavailable unless an add-in video card is installed in a PCIe slot supported by CPU 1.
- Because the onboard video is hardwired to CPU 0, when **Legacy VGA Socket** is set to **CPU Socket 1**, the onboard video is disabled.

7.3.4.3 Dual Monitor Support

The BIOS supports single and dual video when add-in video adapters are installed. No enable/disable option is available in the BIOS setup utility for dual video. It works when both the **Onboard Video** and **add-in Video Adapter** options are enabled.

In the single video mode, the onboard video controller or the add-in video adapter is detected during POST.

In dual video mode, the onboard video controller is enabled and is the primary video device while the add-in video adapter is considered as the secondary video device during POST. The add-in video adapter is not active until the operating system environment is loaded.

8. Intel® Light-Guided Diagnostics

The Intel® Server System M50FCP1UR includes several LEDs used to provide system status and for diagnostic aids. Some LEDs are only viewable from inside of the server chassis. Others are viewable externally from the back of the system or from the system front Control Panel. See section 7.1 for a description of LEDs found on the front Control Panel. This chapter will provide a description for all other LEDs.

8.1 Post Code Diagnostic LEDs

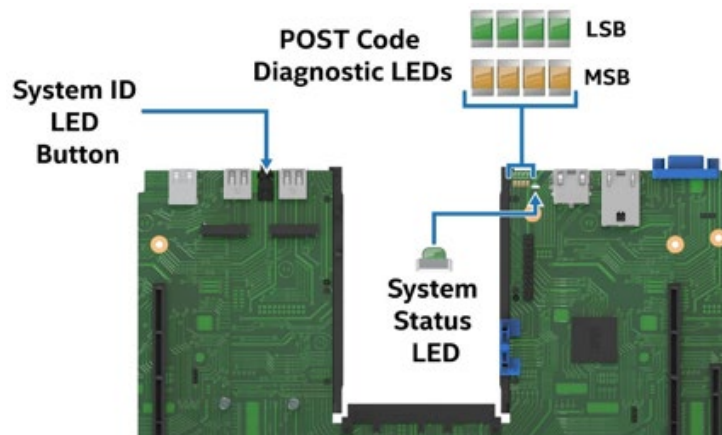

Figure 75. Exploded View of POST Code Diagnostic, System ID, and System Status LEDs

As an aid in troubleshooting system hangs that occur during a system POST process, the server board includes a bank of eight (2X4) diagnostic LEDs on the back edge of the server board. These diagnostic LEDs are used to represent hexadecimal POST progress codes or halt error codes for memory initialization and platform configuration routines from the memory reference code (MRC) and system BIOS.

If a system hangs during POST execution, the displayed POST progress code can be used to identify the last POST routine that was run before the error occurred, helping to isolate the possible cause of the hang condition even when video is not available. See the *Intel® Server Board M50FCP2SBSTD Technical Product Specification* for a complete description of how these LEDs are read, and for a list of all supported POST codes.

8.2 System ID LED

Blue System ID LEDs can be found integrated within System ID buttons on the back edge of the server board (See [Figure 76](#)) and on the system front Control Panel (See [Figure 68](#)). These LEDs are used to visually identify a specific server system when installed in a rack among many other similar systems.

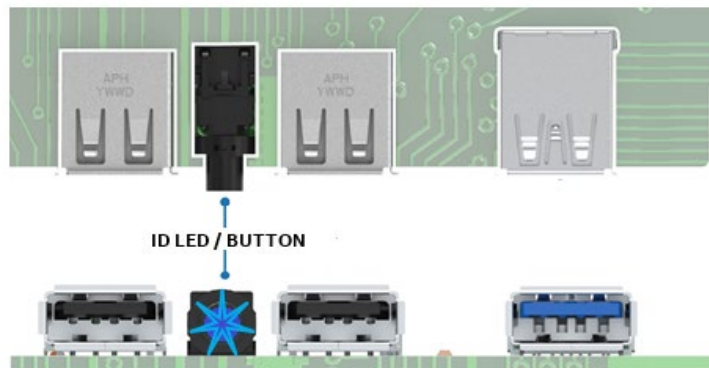

Figure 76. System ID LED / Button

The LED state can be changed using any of three methods:

- Pressing the System ID LED button on the back edge of the server board will produce a solid on state on both the front and rear LEDs and will cause them to stay illuminated until the button is pressed, turning it off.
- Pressing the System ID LED on the system front panel will produce a solid on state on both the front and rear LEDs and will cause them to stay illuminated until the button is pressed, turning it off.
- Issue an IPMI Chassis Identify command. This option causes the System ID LED to blink for up to 2 minutes. The system ID LED on the server board is tied directly to the system ID LED on the system front panel.

8.3 System Status LED

The server board includes a bicolor system status LED. The system status LED is tied directly to the system status LED on the front panel. This LED indicates the current health of the system. Possible LED states include solid green, blinking green, solid amber, and blinking amber. For more details, see [Section 7.1](#).

8.3.1 BMC Boot/Reset Status LED Indicators

During the BMC boot or BMC reset process, the system status LED and system ID LED are used to indicate BMC boot process transitions and states. A BMC boot occurs when the AC power is first applied. (DC power on/off does not reset BMC). BMC reset occurs after a BMC firmware update, on receiving a BMC cold reset command, and following a reset initiated by the BMC watchdog. [Table 28](#) defines the LED states during the BMC boot/reset process.

Table 28. BMC Boot / Reset Status LED State Definition

BMC Boot/Reset State	System ID LED	System Status LED	Comment
BMC/video memory test failed	Solid blue	Solid amber	Nonrecoverable condition. Contact an Intel representative for information on replacing this motherboard.
Both universal bootloader (u-Boot) images bad	6 Hz blinking blue	Solid amber	Nonrecoverable condition. Contact an Intel representative for information on replacing this motherboard.
BMC in u-Boot	3 Hz blinking blue	1 Hz blinking green	Blinking green indicates degraded state (no manageability), blinking blue indicates u-Boot is running but has not transferred control to BMC Linux. Server system will be in this state 6–8 seconds after BMC reset while it pulls the Linux image into flash.
BMC booting Linux*	Solid blue	Solid green	After an AC cycle/BMC reset, indicates that the control has been passed from u-Boot to BMC Linux itself. The system is in this state for 10-20 seconds.
End of BMC boot/reset process. Normal system operation	Off	Solid green	Indicates BMC Linux has booted and manageability functionality is up and running. Fault/status LEDs operate as usual.

8.4 Processor Fault LEDs

The server board includes a processor fault LED for each processor socket (See [Figure 77](#)). The processor fault LED is lit if an MSID mismatch error is detected, indicating that a processor power rating is incompatible with the board.

Table 29. Processor Fault LED State Definition

Component	Managed by	Color	State	Description
Processor Fault LEDs	BMC	Off	Off	Ok (no errors)
		Solid Amber	On	MSID mismatch

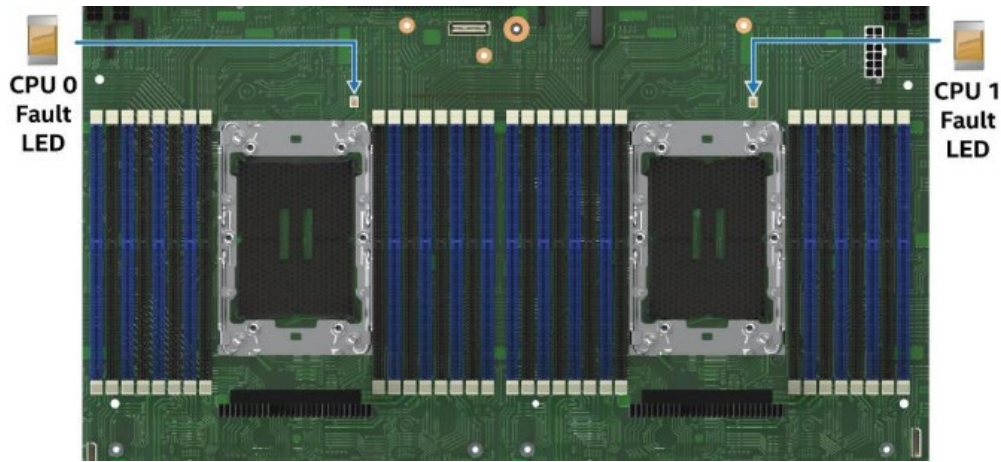

Figure 77. Processor Fault LEDs

8.5 Memory Fault LEDs

The server board includes a memory fault LED for each memory slot (see the following figure). When the BIOS detects a memory fault condition, it sends an IPMI OEM command (`Set Fault Indication`) to the BMC to turn on the associated memory slot fault LED. These LEDs are only active when the system is in the On state. The BMC does not activate or change the state of the LEDs unless instructed by the BIOS.

Table 30. Memory Fault LED State Definition

Managed	Managed by	Color	State	Description
Memory Fault LED	BMC	Off	Off	Memory working correctly
		Solid amber	On	Memory failure: detected by the BIOS

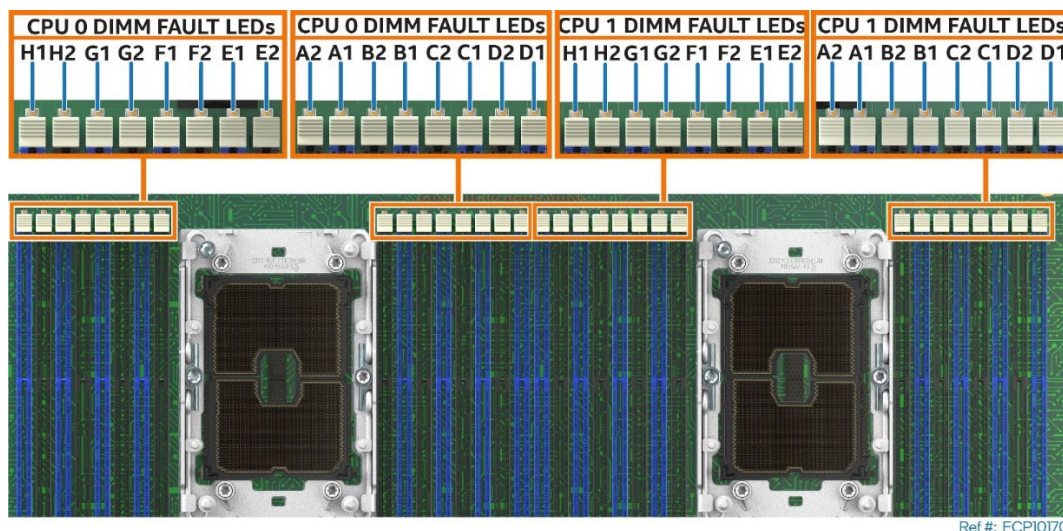

Figure 78. Memory Fault LED Location

8.6 Fan Fault LEDs

A fan fault LED is associated with each system fan (See [Figure 79](#)). The BMC lights a fan fault LED if the associated fan-tach sensor has a lower critical threshold event status asserted. Fan-tach sensors are manual rearm sensors. Once the lower critical threshold is crossed, the LED remains lit until the sensor is rearmed. These sensors are rearmed at system DC power-on and system reset.

Table 31. Fan Fault LED State Definition

Component	Managed by	Color	State	Description
Fan Fault LED	BMC	Off	Off	Fan working correctly
		Solid Amber	On	Fan failed

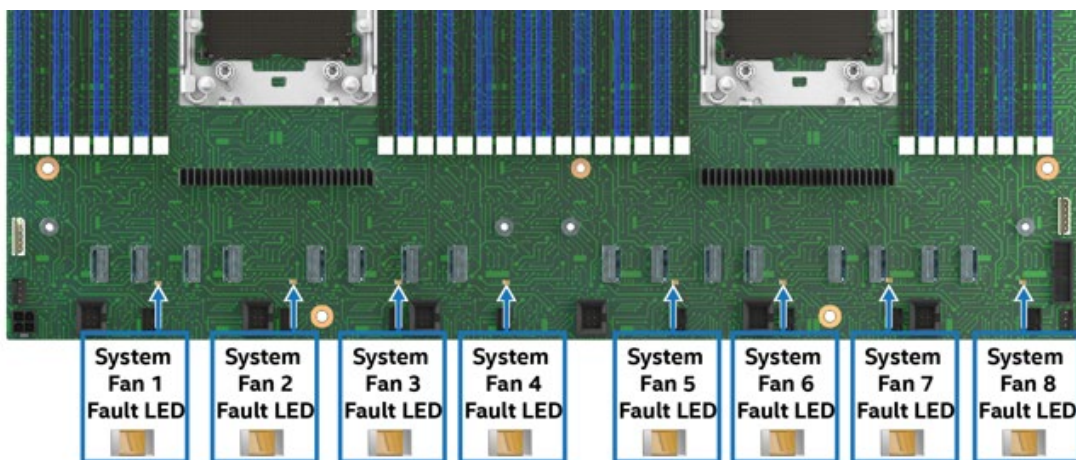

Figure 79. System Fan Fault LEDs

8.7 Additional Light Guided Diagnostics

8.7.1 Power Supply Status LED

See [Section 3.7.1](#).

8.7.2 Front Panel Control LED Indicators

See [Section 7.1](#).

8.7.3 Drive Bay LEDs

See [Section 6.1.1](#) for drive status and drive activity LEDs.

8.7.4 Drive Activity LED for Front Control Panel

See [Section 7.1](#).

Appendix A. Getting Help

Available Intel support options with your Intel Server System:

- 24x7 support through Intel's support webpage at <https://www.intel.com/content/www/us/en/support/products/1201/server-products.html>

Information available at the support site includes:

- Latest BIOS, firmware, drivers, and utilities
- Product documentation, setup, and service guides
- Full product specifications, technical advisories, and errata
- Compatibility documentation for memory, hardware add-in cards, and operating systems
- Server and chassis accessory parts list for ordering upgrades or spare parts
- A searchable knowledge base to search for product information throughout the support site

Quick Links:

Use the following links for support on Intel Server Boards and Server Systems	<p>Download Center</p>  <p>http://www.intel.com/support/downloadserversw</p>	<p>BIOS Support Page</p>  <p>http://www.intel.com/support/server/bios</p>	<p>Troubleshooting Boot Issue</p>  <p>http://www.intel.com/support/tsboot</p>
<p>Use the following links for support on Intel® Data Center Block (DCB) Integrated Systems¹</p> <p>¹ Intel DCB comes prepopulated with processors, memory, storage, and peripherals based on how it was ordered through the Intel Configure to Order tool.</p>	<p>Download Center</p>  <p>http://www.intel.com/support/downloaddcbsw</p>	<p>Technical Support Documents</p>  <p>http://www.intel.com/support/dcb</p>	<p>Warranty and Support Info</p>  <p>http://www.intel.com/support/dcb/warranty</p>

- If a solution cannot be found at Intel's support site, submit a service request via Intel's online service center at <https://supporttickets.intel.com/servicecenter?lang=en-US>. In addition, you can also view previous support requests. (Login required to access previous support requests)
- Contact an Intel support representative using one of the support phone numbers available at <https://www.intel.com/content/www/us/en/support/contact-support.html> (charges may apply).

Intel also offers Partner Alliance Program members around-the-clock 24x7 technical phone support on Intel server boards, server chassis, server RAID controller cards, and Intel® Server Management at <https://www.intel.com/content/www/us/en/partner-alliance/overview.html>.

Note: The 24x7 support number is available after logging in to the Intel Partner Alliance website.

Warranty Information

To obtain warranty information, visit http://www.intel.com/p/en_US/support/warranty.

Appendix B. Software License Key Management

B.1 Ordering Software License Key

There are two options available to order a software license key:

- **CTO/L9:** When ordering a fully integrated system from Intel using its on-line Configure-to-Order (CTO) tool, select the required license key (**AdvSysMgmtKey**, **VROCStanKey** or **VROCPremKey**) as an additional option. The Intel factory will then upload the license key on to the system during the system integration process.
- **Add-on Accessory:** A software license key can be ordered separately from the system as an add-on accessory. This option requires that the license key be manually installed on the system. See the following sections for complete ordering and installation instructions.

B.2 Order and Register a License Key as an Add-on Accessory (Not via CTO)

1. Place an order for the required software license key with electronic delivery. Intel Product Codes:
ADVSYSMGMTKEY for the Advanced System Management (ASM) Key
VROCSTANKEY for the Intel® Virtual RAID on CPU Standard Software Key
VROCPREMKEY for the Intel® Virtual RAID on CPU Premium Software Key
2. Receive an email with instructions to download the product key.
3. From the email, Click the **Register** link (see [Figure 80](#)) to go to <https://servertools.intel.com/registration>

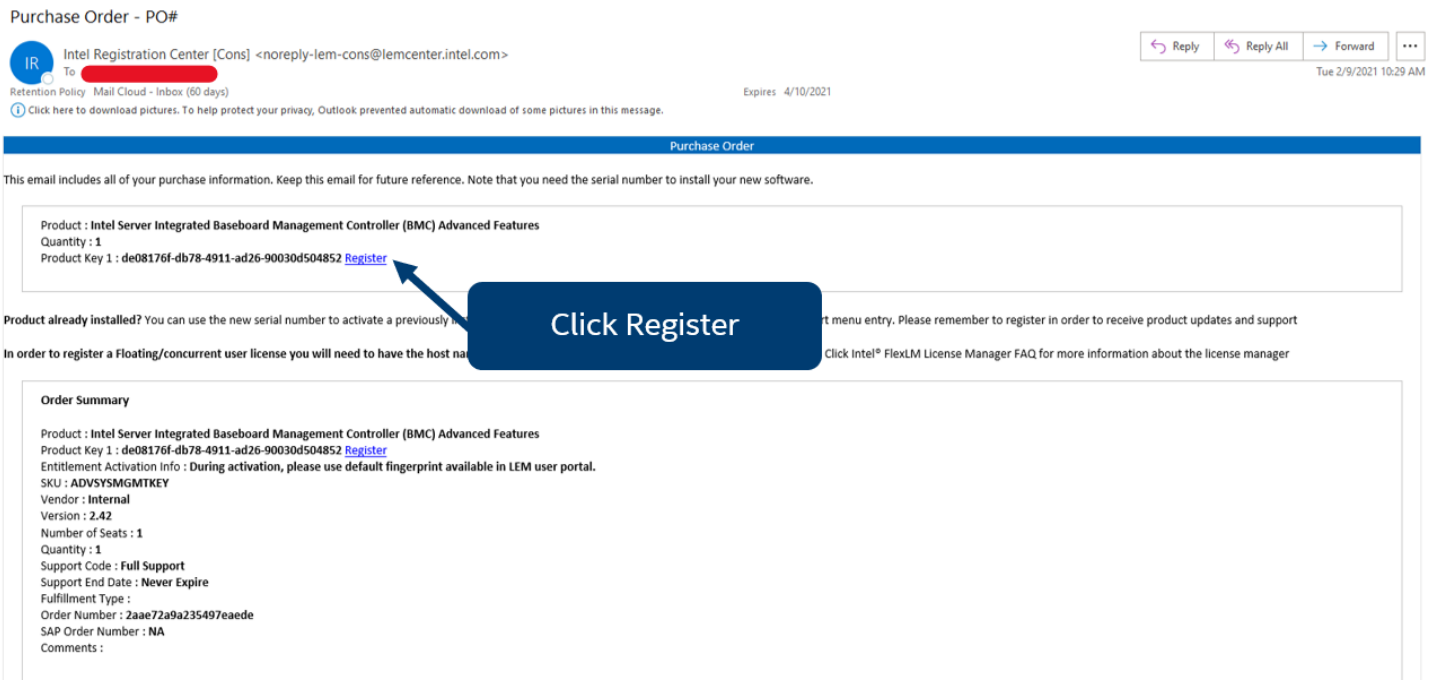

Figure 80. Example Email

4. Login using an existing Intel account or create a new one. An email address is required

5. On the Registration Screen, Click the “Register Product Key” button to register the pre-entered license key number. (see Figure 81)

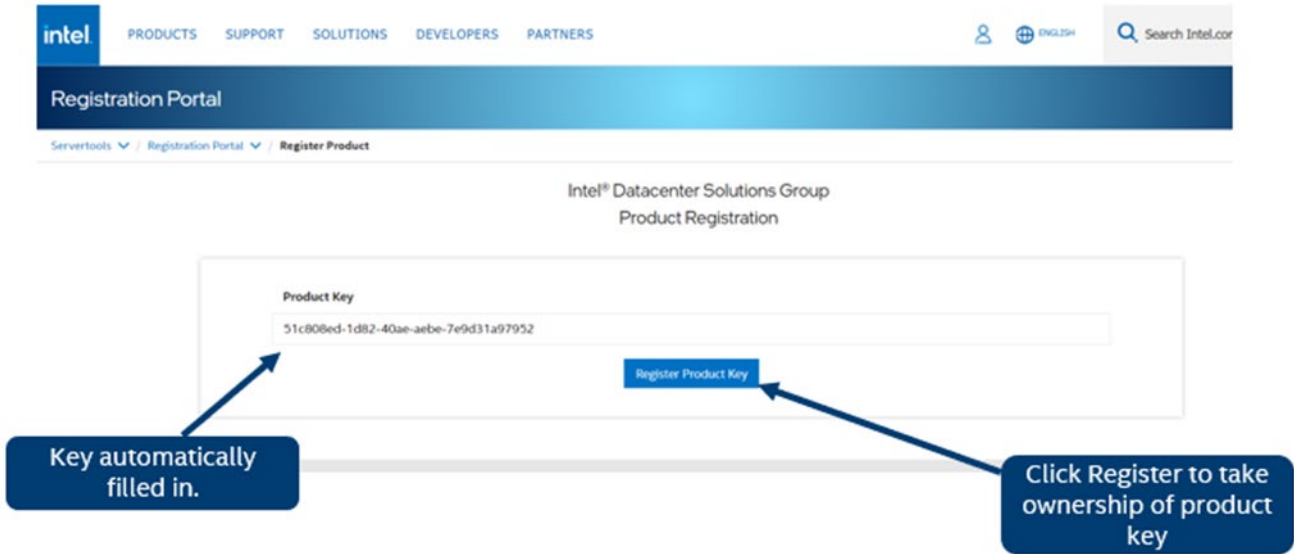

Figure 81. Register Key

6. Enter the number of Advanced System Management (ASM) licenses needed. It must be equal or less that the quantity available displayed on the right corner of the screen. Click on the “Generate License(s)” bottom to download the single license file. (see Figure 82)

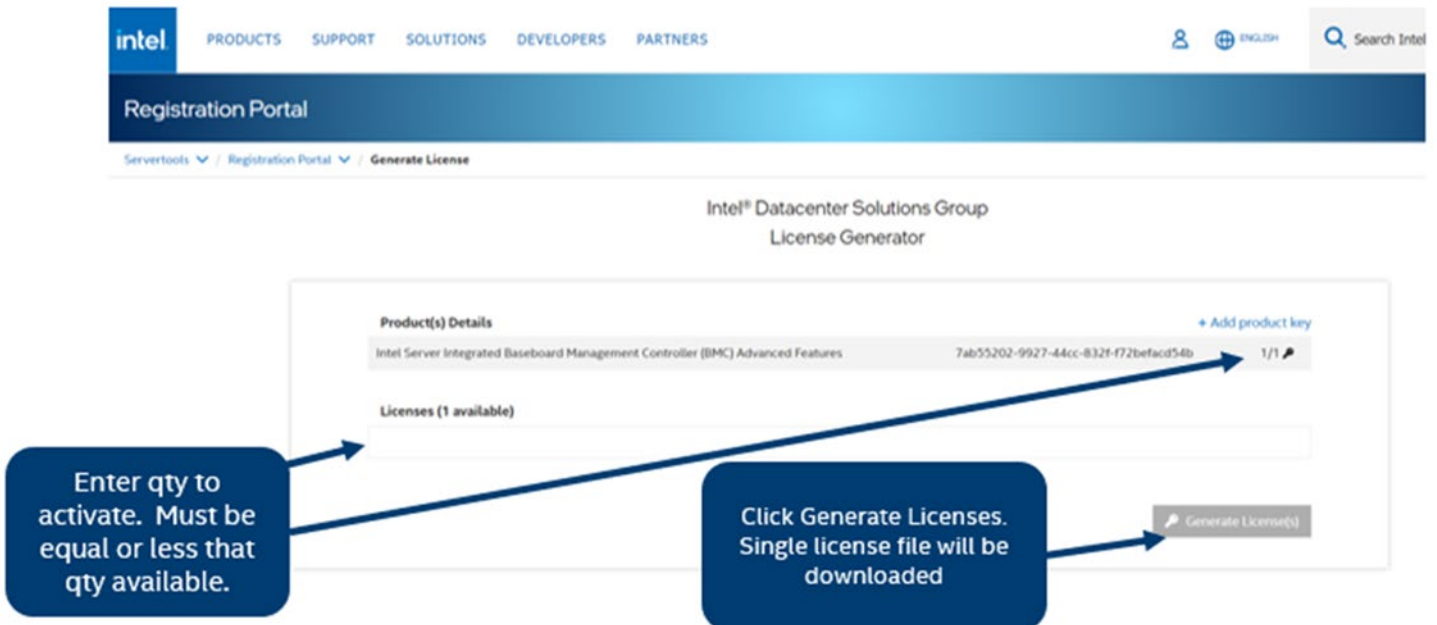

Figure 82. Activate Key for Advanced System Management (ASM) Key

Note: Only single license file per order is needed to activate multiple systems. If any key or email is lost, Intel can generate new product keys as needed.

7. To activate the license for either **VROCSTANKEY** or **VROCPREMKEY**:

- Collect the board serial number. There are several ways to get the board serial number, e.g., barcode label attached to the board, BMC web console, Redfish/IPMI API's and utilities.
- Multiple board serial numbers can be entered in the text box or by uploading a .JSON file with the list. Only a single license file will be downloaded. This single license file will work with all systems that match one of the serial numbers. (see [Figure 83](#))

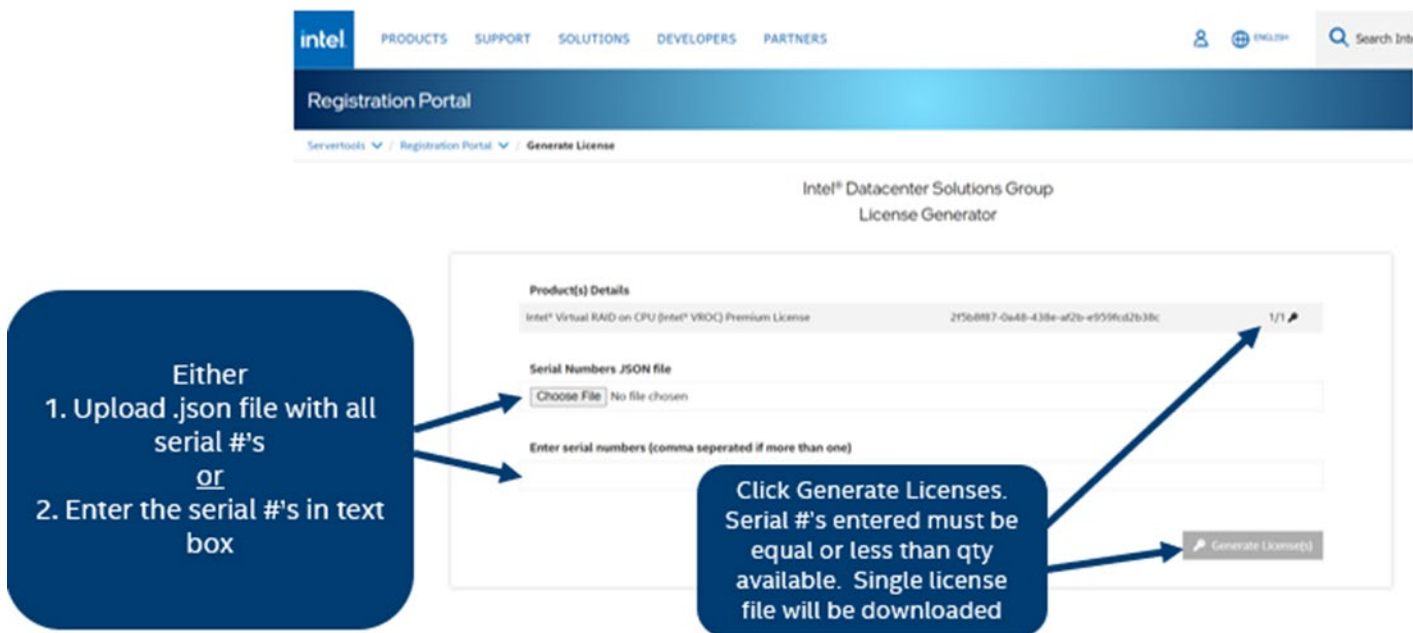

Figure 83. Activate Key for Intel® Virtual RAID on CPU Standard/Premium Software Key

- If using file to upload serial numbers (vs. text box), the following is the JSON format that should be in the file:

```
{ "serialNumbers":
  ["SERIAL1","SERIAL2","SERIAL3"]}
```

Click on “Generate License(s)” bottom to download the single license file. The quantity of the board serial numbers entered must be equal or less than the quantity available displayed on the right corner of the screen.

Note: Make sure to enter the board serial number NOT the product serial number. Only one of the two methods either the JSON file or the text box is accepted. The license file will work with all systems that match one of the board serial numbers. If any key or email is lost, Intel can generate new product keys as needed.

8. Upload the license key file to the BMC.

B.3 Software License Key Installation

Three available options can be used to upload a software license onto a server:

- Integrated BMC Web Console
- Intel® Server Configuration Utility
- Redfish* Interface

B.3.1 Installation Using the Integrated BMC Web Console

The following procedure may be used to upload and confirm activation of a software license key. The example below illustrates the process of uploading the Advanced System Management (ASM) license using the Integrated BMC Web Console. The same process can be used to upload VROC software license key.

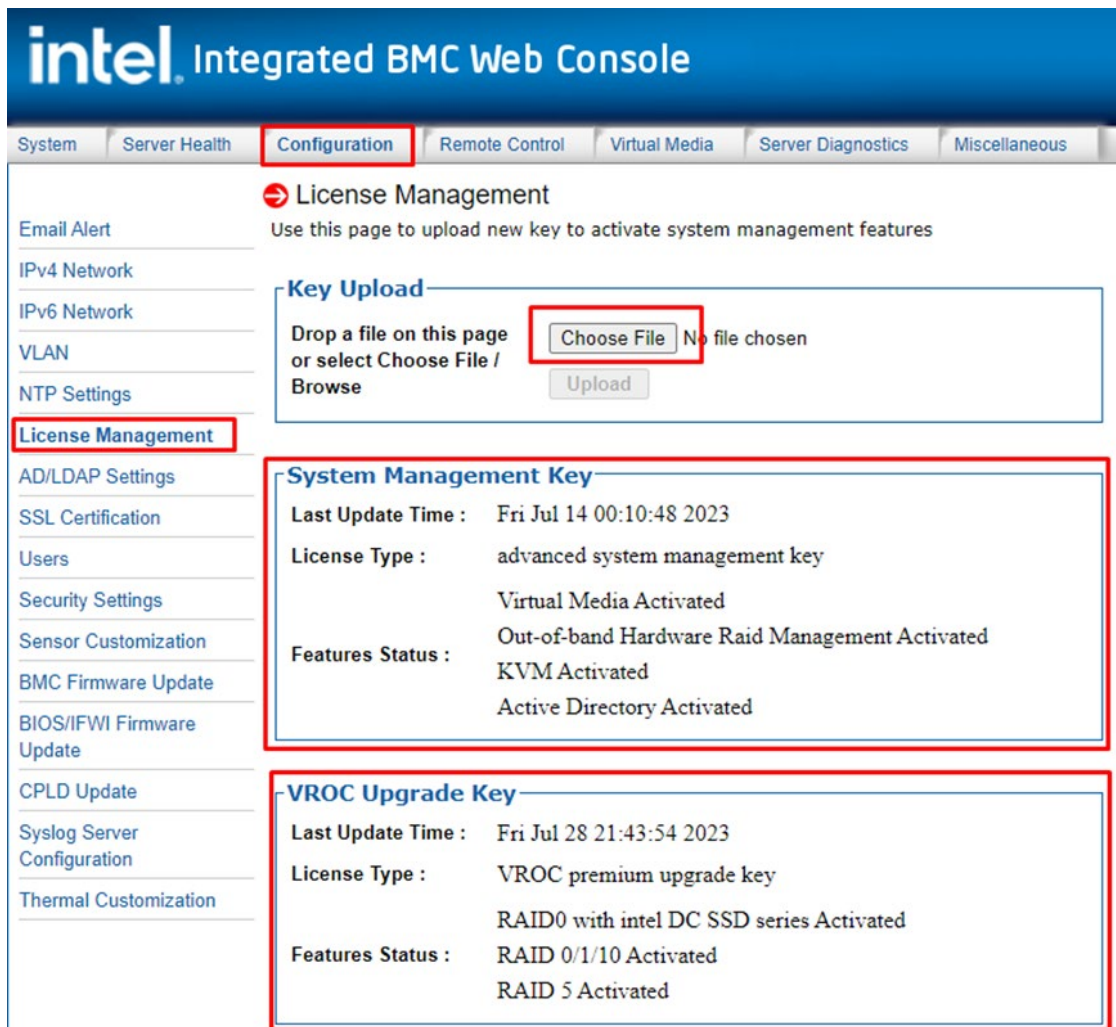
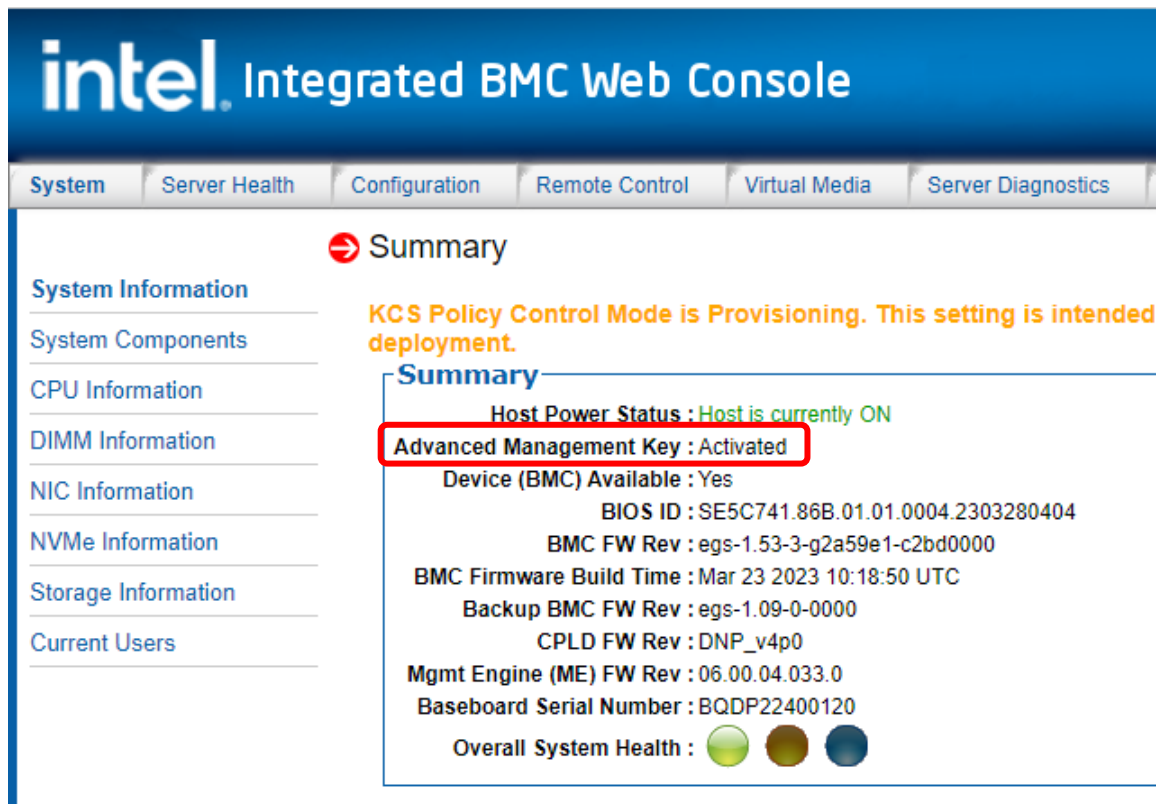

Figure 84. Integrated BMC Web Console Advanced System Management Key Page

1. Login to the Integrated BMC Web Console
2. Navigate to the **Configuration > License Management** page
3. Click the **Choose File** button to select the license key file
4. Select the **.v2c** license key file, then click the **Open** button
5. Click the **Upload** button to upload the ASM License Key or VROC software License key to the BMC
6. The **System Management Key/VROC Upgrade Key** section will show the license type and activated features
7. Navigate back to the **System** Tab. On the **System Information** page, view the **System Summary** information box to confirm the **Advanced Management Key** was successfully **Activated**.



intel Integrated BMC Web Console

System | Server Health | Configuration | Remote Control | Virtual Media | Server Diagnostics

➔ Summary

System Information

System Components

CPU Information

DIMM Information

NIC Information

NVMe Information

Storage Information

Current Users

KCS Policy Control Mode is Provisioning. This setting is intended deployment.

Summary

Host Power Status : Host is currently ON

Advanced Management Key : Activated

Device (BMC) Available : Yes

BIOS ID : SE5C741.86B.01.01.0004.2303280404

BMC FW Rev : egs-1.53-3-g2a59e1-c2bd0000

BMC Firmware Build Time : Mar 23 2023 10:18:50 UTC

Backup BMC FW Rev : egs-1.09-0-0000

CPLD FW Rev : DNP_v4p0

Mgmt Engine (ME) FW Rev : 06.00.04.033.0

Baseboard Serial Number : BQDP22400120

Overall System Health : ● ● ●

Figure 85. BMC Web Console System Information Page

B.3.2 Installation Using the Intel® Server Configuration Utility

The following procedure may be used to upload and confirm activation of the license keys using the syscfg command line utility.

To download the latest utility package, go to <https://downloadcenter.intel.com/> and search for the “Intel Server Configuration Utility”.

Prerequisites:

- Ensure the user has Administrator or Root privileges for the chosen operating system
- Ensure the KCS Policy Control Mode is set to “**Provisioning**”

Procedure:

1. Install the Intel® Server Configuration Utility on to the target server system. See the Intel® Server Configuration Utility User Guide for installation instructions.
2. Navigate to the sub-directory where the Server Configuration Utility was installed
3. From a command prompt run the following command

syscfg /lic <key file name>

where “file name” can be just the name of the license file if copied to the same directory as the syscfg command file, or the complete path of where the license key was copied can be entered along with the file name.

The example below illustrates the process of uploading the VROC standard software license key. The same process can be used to upload the Advanced Server Management license key.

```

C:\SYSCFG 16.0.9>syscfg.exe /lic VROCSTANKEY.v2c

Server Configuration Utility Version 16.0.9
Copyright (c) 2023 Intel Corporation

Key Transfer...
Starting key upload:
Key Upload done

VROC license is uploaded successfully

C:\SYSCFG 16.0.9>

```

Figure 86. Upload VROC Standard License Key Using SYSCFG Utility

4. To confirm activation of the VROC license key, type the following command:

syscfg /d lic

```

C:\SYSCFG 16.0.9>syscfg.exe /d lic

License Status
-----
Type | Status | Time Stamp
-----|-----|-----
ASM key | Activated | 04/16/2023-11:37:04
VROC standard key | Activated | 04/16/2023-11:41:27
VROC premium upgrade key | Not Activated |
-----
C:\SYSCFG 16.0.9>

```

Figure 87. Confirm Activation of VROC Standard License Key Using SYSCFG Utility

B.3.3 Installation Using Redfish*

The following steps may be used to upload and confirm activation of a software license key using Redfish*.

Prerequisites:

- If not already present, install the “curl” and “grep” utilities onto the system from which the commands will be run.

Issue the following command to upload a software license key to the BMC

```
curl -k -u username:password
```

```
https://BMC_IP/redfish/v1/UpdateService/SoftwareInventory/LicenseManagement/Actions/Oem/Intel.Oem.Upload -H "Content-Type: multipart/form-data" -F "updateFile=@filepath" -X POST
```

Notes:

- The command line above is a single command line
- username:password in the command line above should be replaced with the name of the user and their password

See the example below where:

- username = admin
- password = password
- BMC_IP = 192.168.0.102
- filepath = VROCPREMKEY.v2c

```
C:\SYS CFG 16.0.9>curl -k -u admin:password
https://192.168.0.102/redfish/v1/UpdateService/SoftwareInventory/LicenseManagement/Actions/Oem/Intel.Oem.Upload -H
"Content-Type: multipart/form-data" -F "file=@VROCPREMKEY.v2c" -X POST
{
  "@odata.id": "/redfish/v1/TaskService/Tasks/2",
  "@odata.type": "#Task.v1_4_3.Task",
  "Id": "2",
  "TaskState": "Running",
  "TaskStatus": "OK"
}
C:\SYS CFG 16.0.9>
```

Figure 88. Redfish Command to Upload the VROC Premium Software License Key

Issue the following command to verify the activation status of the license keys.

```
curl -k -u username:password
https://BMC_IP/redfish/v1/UpdateService/SoftwareInventory/LicenseManagement#Oem/LicenseInventory/Licenses -H "content-type: application/json" -X GET | grep -A1 LicenseStatus
```

```
C:\SYS CFG 16.0.9>curl -k -u admin:password
https://192.168.0.102/redfish/v1/UpdateService/SoftwareInventory/LicenseManagement#Oem/LicenseInventory/Licenses -H
"content-type: application/json" -X GET | grep -A1 LicenseStatus
% Total    % Received % Xferd Average Speed   Time    Time     Time  Current
   Dload  Upload  Total   Spent    Left   Speed
100 3306    100 3306    0     0  6480    0 --:--:-- --:--:-- --:--:--  6507
"LicenseStatus": "ACTIVATED",
"LicenseType": "advanced system management key",
--
"LicenseStatus": "ACTIVATED",
"LicenseType": "VROC premium upgrade key",
```

Figure 89. Redfish Command to verify the activation status of the VROC Software License Key

Appendix C. Integration and Usage Tips

This appendix provides a list of useful information that is unique to the Intel® Server System M50FCP1UR and should be kept in mind while configuring your server system.

- When adding or removing components or peripherals from the server board, power cords must be disconnected from the server. With power applied to the server, standby voltages are still present even though the server board is powered off.
- The server boards support the 4th & 5th Gen Intel® Xeon® Scalable processor family with a maximum Thermal Design Power (TDP) that is configuration dependent (See [Table 2](#)). Previous generations of the Intel® Xeon® processor and Intel® Xeon® Scalable processor families are not supported.
- Processors must be installed in order. CPU 0 must be populated for the server board to operate.
- Many features of the server board are only supported in dual processor configurations (See [Figure 7](#)).
- The riser card slots are specifically designed to support riser cards only. Attempting to install a PCIe add-in card directly into a riser card slot on the server board may damage the server board, the add-in card, or both.
- For the best performance, the number of DDR5 DIMMs installed should be balanced across both processor sockets and memory channels.
- On the back edge of the server board, there are eight diagnostic LEDs that display a sequence of POST codes during the boot process. If the server board hangs during POST, the LEDs display the last POST event run before the hang.
- The system status LED is set to a steady amber color for all fatal errors that are detected during processor initialization. A steady amber system status LED indicates that an unrecoverable system failure condition has occurred.
- RAID partitions created using either Intel® VMD cannot span across the two embedded SATA controllers. Only drives attached to a common SATA controller can be included in a RAID partition.
- Make sure that the latest system software is loaded on the server. The software includes system BIOS, BMC firmware, Intel® ME firmware and FRU/SDR information. The latest system software can be downloaded from <http://downloadcenter.intel.com>.

Appendix D. System Configuration Table for Thermal Compatibility

This appendix provides tables that list system configuration compatibility data based on various supported system operating thermal limits. Section C.1 identifies supported system configurations for systems operating in a “normal” operating mode. In a normal operating mode, all system fans are present, online, and operational.

Section C.2 identifies supported system configurations for systems operating in a “fan fail” mode. In a fan fail mode, one fan rotor within the system is in a failed state. The system is still operational. However, fan redundancy is lost. System throttling may occur, impacting system performance. The system cannot keep system thermals below upper critical limits if >1 fan rotors fail.

Some system configurations can operate at elevated ASHRAE Class A3 and A4 environmental limits for specific amounts of time per year without impacting long term reliability.

- ASHRAE Class A3 – Includes operation up to 40C for up to 900 hours per year
- ASHRAE Class A4 – Includes operation up to 45C for up to 90 hours per year

Note: A system operating at elevated ambient temperatures may initiate thermal throttling which will impact system performance. See Note #2 in the following list.

The following configuration support notes may not apply to ALL system configurations. Applicable notes for specific system configurations will be identified by number for in tables 29 and 30.

Thermal Configuration Support Notes:

Environment

1. In the following tables, any configuration specified with a constrained ambient temperature that is less than 35C, is limited to a maximum altitude of 900m. Altitudes higher than 900m require the ambient temperature to be de-rated an additional 1C per 300m above 900m.
2. For ASHRAE Class 3 and Class 4 support, the following power supply margining is required to meet thermal specifications:
 - For dual power supply configurations, the system power budget must fit within a single power supply rated load with both power supplies installed.
 - For single power supply configurations, the power budget must be sized with 30% margin to single power supply rated load.

Processor/DIMM

3. Follow TMSDG rev1p6 to evaluate CPU support matrix.
4. CPU support matrix and FSC DTS 2.0 are based on CPU base configuration of TMSDG. If the end user change to other CPU configuration mode. It is possibility to see performance impact.

5. Processor and Memory throttling may occur with ambient temperatures $\leq 10\text{C}$ over 35C . System performance may be impacted, but the system will remain operational.
6. Heavy processor and memory throttling will occur with ambient temperatures $>10\text{C}$ over 35C . System performance will be impacted, but the system will remain operational.

Key System Components

7. A power supply inlet temperature sensor that exceeds 61C OTP will influence system power and impact system performance.
8. Use of the designated PCIe slot is limited to add-in cards that have airflow requirements of 100 LFM or less. See add-in card specs for airflow requirements.
9. 1U R1204 system configurations have support for OCP V3 add-in cards with a max 25W power consumption. 1U R1212 system configurations have support for OCP V3 add-in cards with a max 15W power consumption.
10. M.2 drives are limited to OS and boot only and may see performance impact under heavy work load.
11. Intel® NVME drives used for thermal testing.
12. If the end user installs any SSD in the system w/o NVME sensor temp reading in EWS, the end user should manually turn fan profile to “Performance” mode in BIOS.
13. If the end user installs any GPGPU in the system w/o itself sensor temp reading in EWS, the end user should manually turn fan profile to “Performance” mode in BIOS.
14. See Chapter 4 for thermal limitations.

System

15. Only low profile PCIe add-in cards are supported in all 1U system configurations.
16. R1212 can support 205W processors with standard 1U CPU heat sinks with normal fan stats.
17. R1204 can support 350W processors with 1U EVAC CPU heat sink with normal fan stats.
18. If the end user installs NVIDIA* A2 GPGPU, the end user should manually set fan duty to 100%. If end user doesn't manually set fan duty to 100%, R1212/ R1204 can support NVIDIA A2 card at $15\text{c}/ 20\text{c}$ and normal fan status with performance mode. Testing is based on max GPU power. NVIDIA GPUs support programmable power that customer can use to cap GPU power and decrease ambient temperature requirement.
19. Flex140 (75W) support in R1212/ R1204 at 35C and normal fan status with performance mode.
20. System cooling capability testing was carried out in environmental lab-controlled conditions according to the ASHRAE standard.
21. Performance depends on data center environmental temperature and relative humidity levels controls provided by end user.
22. It is the responsibility of the system integrator to both consider the thermal configuration matrix and power budget tool documents to arrange end use configuration

Fan Failure

23. To support system fan redundancy, the system must be configured with two power supplies to maintain sufficient cooling. Concurrent system and power supply fan failures is not supported.

24. With fan redundancy lost, DIMM and CPU throttling may occur, impacting system performance. However, the system should remain operational.
25. In fan fail mode, Intel® OCP 3.0 Modules are only supported in the specified base system model configured.

Single processor

26. Intel does not consider a single processor configuration as standard for this system product family. No fan fail testing was performed on single processor configurations.
27. In a single processor configuration, only Riser Slot #1, the OCP 3.0 connector, and eight of sixteen PCIe MCIO cable connectors are functional. Riser Slot #2, Riser Slot #3, the Interposer Riser Slot, and the 2nd set of eight PCIe MCIO cable connectors are only supported in dual processor configurations (See Figure 7).

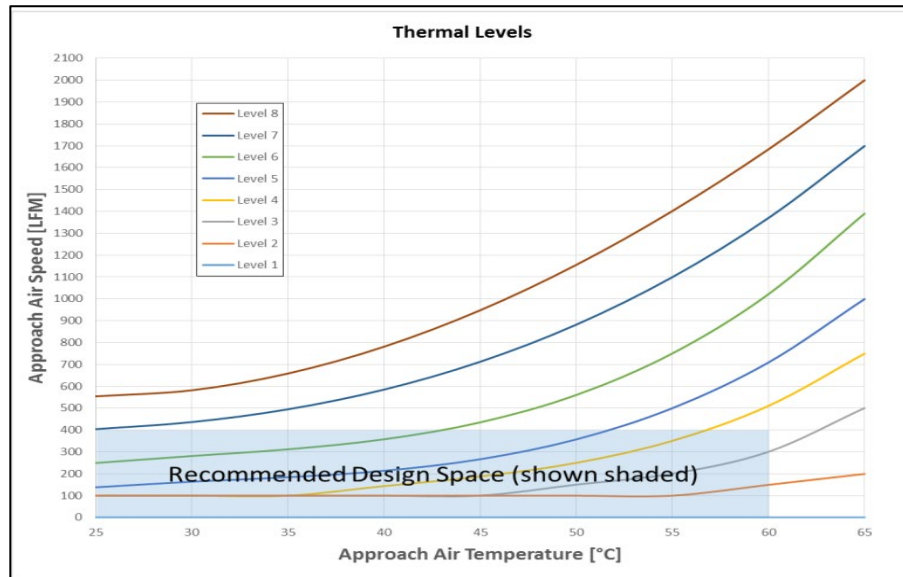

Figure 90. PCIe SIG Add-in cards thermal levels

C.1 Normal Operating Mode/Fan Fail Mode with Dual Processor Installed

Table 32. Thermal testing results interpretation for air-cooled systems

● ●	System is capable of full performance
● ○	System is capable of full performance but may throttle in fan failure mode
○ ○	System may experience some performance loss at high workloads
● -	System capable of full performance but system cooling is not redundant
○ -	System may experience some performance loss and cooling is not redundant
-	Configuration is not supported

Table 33. Thermal Configuration Matrix with Dual 4th Gen Processor Installed – Normal Operating Mode/Fan Fail mode (M50FCP1UR204)

Intel® Server M50FCP1UR204, 1U EVAC, Air-cooled								
Max Ambient Temperature	15°C	20°C	25°C	27°C	32°C	35°C	40°C	45°C
CPU SKU	CPU Support (TDP 350W)							
Intel® Xeon® Platinum 8490H, 350W, 60C	●●	●●	●●	●●	●○	○-	○-	-
Intel® Xeon® Platinum 8480+, 350W, 56C	●●	●●	●●	●●	●○	○-	○-	-
Intel® Xeon® Platinum 8470, 350W, 52C	●●	●●	●●	●●	●○	○-	○-	-
Intel® Xeon® Platinum 8468, 350W, 48C	●●	●●	●●	●●	●○	○-	○-	-
Intel® Xeon® Platinum 8458P, 350W, 44C	●●	●●	●●	●●	●○	○-	○-	-
Intel® Xeon® Platinum 8468V, 330W, 48C	●●	●●	●●	●●	●○	○-	○-	-
Intel® Xeon® Platinum 8468H, 330W, 48C	●●	●●	●●	●●	●○	○-	○-	-
Intel® Xeon® Platinum 8460H, 330W, 40C	●●	●●	●●	●●	●○	○-	○-	-
Intel® Xeon® Platinum 8471N, 300W, 52C	●●	●●	●●	●●	●○	●○	○-	-
Intel® Xeon® Platinum 8470N, 300W, 52C	●●	●●	●●	●●	●○	●○	○-	-
Intel® Xeon® Platinum 8461V, 300W, 48C	●●	●●	●●	●●	●○	●○	○-	-
Intel® Xeon® Platinum 8460Y+, 300W, 40C	●●	●●	●●	●●	●○	●○	○-	-
Intel® Xeon® Platinum 8452Y, 300W, 36C	●●	●●	●●	●●	●●	●●	●-	-
Intel® Xeon® Gold 6454S, 270W, 32C	●●	●●	●●	●●	●○	●○	○-	-
Intel® Xeon® Platinum 8454H, 270W, 32C	●●	●●	●●	●●	●○	●○	○-	-
Intel® Xeon® Gold 6430, 270W, 32C	●●	●●	●●	●●	●○	●○	○-	-
Intel® Xeon® Platinum 8444H, 270W, 16C	●●	●●	●●	●●	●○	●○	○-	-
Intel® Xeon® Gold 6414U, 250W, 32C	●●	●●	●●	●●	●●	●●	●○	○-
Intel® Xeon® Platinum 8450H, 250W, 28C	●●	●●	●●	●●	●●	●●	●○	○-
Intel® Xeon® Platinum 8462Y+, 300W, 32C	●●	●●	●●	●●	●○	○○	-	-
Intel® Xeon® Gold 6444Y, 270W, 16C	●●	●●	●●	●●	●○	○○	○-	-
Intel® Xeon® Gold 6448H, 250W, 32C	●●	●●	●●	●●	●●	●●	●○	○-

Intel® Server System M50FCP1UR Technical Product Specification

Intel® Xeon® Gold 6448Y, 225W, 32C	●●	●●	●●	●●	●●	●●	●○	○-
Intel® Xeon® Gold 6442Y, 225W, 24C	●●	●●	●●	●●	●●	●●	●○	○-
Intel® Xeon® Gold 6438M, 205W, 32C	●●	●●	●●	●●	●●	●●	●●	●-
Intel® Xeon® Gold 6438N, 205W, 32C	●●	●●	●●	●●	●●	●●	●●	●-
Intel® Xeon® Gold 6438Y+, 205W, 32C	●●	●●	●●	●●	●●	●●	●○	○-
Intel® Xeon® Gold 5420+, 205W, 28C	●●	●●	●●	●●	●●	●●	●●	●-
Intel® Xeon® Gold 6434, 195W, 8C	●●	●●	●●	●●	●○	●○	○○	-
Intel® Xeon® Gold 6434H, 195W, 8C	●●	●●	●●	●●	●○	●○	○○	-
Intel® Xeon® Gold 6428N, 185W, 32C	●●	●●	●●	●●	●●	●●	●●	●●
Intel® Xeon® Gold 6421N, 185W, 32C	●●	●●	●●	●●	●●	●●	●●	●●
Intel® Xeon® Gold 5418Y, 185W, 24C	●●	●●	●●	●●	●●	●●	●●	●●
Intel® Xeon® Gold 6418H, 185W, 24C	●●	●●	●●	●●	●●	●●	●●	●●
Intel® Xeon® Gold 5412U, 185W, 24C	●●	●●	●●	●●	●●	●●	●●	●●
Intel® Xeon® Gold 6426Y, 185W, 16C	●●	●●	●●	●●	●●	●●	●●	●●
Intel® Xeon® Gold 5418N, 165W, 24C	●●	●●	●●	●●	●●	●●	●●	●●
Intel® Xeon® Gold 5411N, 165W, 24C	●●	●●	●●	●●	●●	●●	●●	●●
Intel® Xeon® Silver 4416+, 165W, 20C	●●	●●	●●	●●	●●	●●	●●	●●
Intel® Xeon® Gold 6416H, 165W, 18C	●●	●●	●●	●●	●●	●●	●●	●●
Intel® Xeon® Gold 5416S, 150W, 16C	●●	●●	●●	●●	●●	●●	●●	●●
Intel® Xeon® Silver 4410Y, 150W, 12C	●●	●●	●●	●●	●●	●●	●●	●●
Intel® Xeon® Gold 5415+, 150W, 8C	●●	●●	●●	●●	●●	●●	●●	●●
Intel® Xeon® Bronze 3408U, 125W, 8C	●●	●●	●●	●●	●●	●●	●●	●●
Intel® Xeon® Silver 4410T, 150W, 10C	●●	●●	●●	●●	●●	●●	●●	●●
Memory Type	Memory Support							
DDR5, DRx8, 1x, 1DPC	●●	●●	●●	●●	●●	●●	●●	●●
DDR5, DRx4, 1x, 1DPC	●●	●●	●●	●●	●○	●○	●○	○○

DDR5, QRx4, 1x, 1DPC	●●	●●	●○	●○	●○	●○	○○	-
DDR5, DRx8, 1x, 2DPC	●●	●●	●●	●●	●●	●●	●●	●●
DDR5, DRx4, 1x, 2DPC	●●	●●	●●	●●	●●	●●	●●	●●
DDR5, QRx4, 1x, 2DPC	●●	●●	●●	●●	●●	●●	●●	●○
DDR5, DRx8, 2x, 1DPC	●●	●●	●●	●●	●●	●●	●●	●●
DDR5, DRx4, 2x, 1DPC	●●	●●	●●	●●	●●	●●	●○	●○
DDR5, QRx4, 2x, 1DPC	●●	●●	●●	●●	●○	●○	●○	○○
DDR5, DRx8, 2x, 2DPC	●●	●●	●●	●●	●●	●●	●●	●●
DDR5, DRx4, 2x, 2DPC	●●	●●	●●	●●	●●	●●	●●	●●
DDR5, QRx4, 2x, 2DPC	●●	●●	●●	●●	●●	●●	●●	●●
PCI Card Cooling	Supported Thermal Level							
Riser 1	LEVEL8 / LEVEL8	LEVEL8 / LEVEL8	LEVEL8 / LEVEL7	LEVEL8 / LEVEL7	LEVEL7 / LEVEL5	LEVEL7 / LEVEL5	LEVEL5 / LEVEL3	LEVEL3 / LEVEL2
Interposer-Riser	LEVEL8 / LEVEL8	LEVEL8 / LEVEL8	LEVEL8 / LEVEL7	LEVEL7 / LEVEL6	LEVEL7 / LEVEL6	LEVEL6 / LEVEL5	LEVEL5 / LEVEL4	LEVEL5 / LEVEL3
Riser 2	LEVEL8 / LEVEL8	LEVEL8 / LEVEL8	LEVEL8 / LEVEL7	LEVEL8 / LEVEL7	LEVEL7 / LEVEL6	LEVEL7 / LEVEL5	LEVEL5 / LEVEL3	LEVEL4 / LEVEL2
2.5" PCIe NVMe SSD	2.5" PCIe NVMe SSD Support							
NVMe TDP = 25W, Rated to 70C	●●	●●	●●	●●	●●	●●	●●	●●
GPGPU card type	GPGPU card Support							
Nvidia Tesla A2 - LP- 60W	●-	●-	●-	●-	-	-	-	-
Intel ATS M3 - LP- 75W	●-	●-	●-	●-	●-	●-	-	-
PSU	PSU Support (Fan normal: 350W / Fan fail: 250W)							
1600W	●●	●●	●●	●●	●●	●●	●●	-
1300W	●●	●●	●●	●●	●●	●●	●●	-
OCP V3	OCP V3 Support							

Intel® Server System M50FCP1UR Technical Product Specification

OCP 25W w/ class-2 QSFP	••	••	••	••	•-	•-	-	-
OCP 15W w/ class-2 QSFP	••	••	••	••	••	••	-	-
Battery Backup	Battery Support							
BBU, Rated to 45C	••	••	••	••	••	••	•-	-

Table 34. Thermal Configuration Matrix with Dual 4th Gen Processor Installed – Normal Operating Mode/Fan Fail mode (M50FCP1UR212)

Intel® Server M50FCP1UR212, 1U, Air-cooled								
Max Ambient Temperature	15°C	20°C	25°C	27°C	32°C	35°C	40°C	45°C
CPU SKU	CPU Support (TDP 205W)							
Intel® Xeon® Gold 6438M, 205W, 32C	●●	●●	●-	●-	●-	●-	-	-
Intel® Xeon® Gold 6438N, 205W, 32C	●●	●●	●-	●-	●-	●-	-	-
Intel® Xeon® Gold 6438Y+, 205W, 32C	●●	●○	●-	●-	○-	-	-	-
Intel® Xeon® Gold 5420+, 205W, 28C	●●	●●	●-	●-	●-	○-	-	-
Intel® Xeon® Gold 6434, 195W, 8C	●○	○○	○-	-	-	-	-	-
Intel® Xeon® Gold 6434H, 195W, 8C	●○	○○	○-	-	-	-	-	-
Intel® Xeon® Gold 6428N, 185W, 32C	●●	●●	●●	●-	●-	●-	○-	-
Intel® Xeon® Gold 6421N, 185W, 32C	●●	●●	●●	●-	●-	●-	○-	-
Intel® Xeon® Gold 5418Y, 185W, 24C	●●	●●	●●	●-	●-	●-	○-	-
Intel® Xeon® Gold 6418H, 185W, 24C	●●	●●	●●	●-	●-	●-	○-	-
Intel® Xeon® Gold 5412U, 185W, 24C	●●	●●	●●	●-	●-	●-	○-	-
Intel® Xeon® Gold 6426Y, 185W, 16C	●●	●●	●●	●-	●-	●-	○-	-
Intel® Xeon® Gold 5418N, 165W, 24C	●●	●●	●●	●●	●-	●-	●-	-
Intel® Xeon® Gold 5411N, 165W, 24C	●●	●●	●●	●●	●-	●-	●-	-
Intel® Xeon® Silver 4416+, 165W, 20C	●●	●●	●●	●●	●-	●-	●-	-
Intel® Xeon® Gold 6416H, 165W, 18C	●●	●●	●●	●●	●-	●-	●-	-
Intel® Xeon® Gold 5416S, 150W, 16C	●●	●●	●●	●●	●●	●-	●-	-
Intel® Xeon® Silver 4410Y, 150W, 12C	●●	●●	●●	●●	●●	●-	●-	-
Intel® Xeon® Gold 5415+, 150W, 8C	●●	●●	●●	●●	●●	●-	●-	-
Intel® Xeon® Bronze 3408U, 125W, 8C	●●	●●	●●	●●	●●	●●	●-	●-
Intel® Xeon® Silver 4410T, 150W, 10C	●●	●●	●●	●●	●●	●-	●-	-
Memory Type	Memory Support							

Intel® Server M50FCP1UR212, 1U, Air-cooled								
Max Ambient Temperature	15°C	20°C	25°C	27°C	32°C	35°C	40°C	45°C
DDR5, DRx8, 1x, 1DPC	●●	●●	●●	●●	●●	●●	●○	●○
DDR5, DRx4, 1x, 1DPC	●●	●○	●○	●○	●○	○○	○○	-
DDR5, QRx4, 1x, 1DPC	●○	●○	●○	●○	○○	-	-	-
DDR5, DRx8, 1x, 2DPC	●●	●●	●●	●●	●●	●●	●●	●●
DDR5, DRx4, 1x, 2DPC	●●	●●	●●	●●	●●	●●	●●	●○
DDR5, QRx4, 1x, 2DPC	●●	●●	●●	●●	●●	●○	●○	●○
DDR5, DRx8, 2x, 1DPC	●●	●●	●●	●●	●●	●●	●●	●●
DDR5, DRx4, 2x, 1DPC	●●	●●	●○	●○	●○	●○	●○	○○
DDR5, QRx4, 2x, 1DPC	●○	●○	●○	●○	●○	○○	○○	-
DDR5, DRx8, 2x, 2DPC	●●	●●	●●	●●	●●	●●	●●	●●
DDR5, DRx4, 2x, 2DPC	●●	●●	●●	●●	●●	●●	●●	●●
DDR5, QRx4, 2x, 2DPC	●●	●●	●●	●●	●●	●●	●○	●○
PCI Card Cooling	Supported Thermal Level							
Riser 1	LEVEL8 / LEVEL7	LEVEL7 / LEVEL6	LEVEL7 / LEVEL6	LEVEL6 / LEVEL5	LEVEL6 / LEVEL5	LEVEL5 / LEVEL3	LEVEL4 / LEVEL2	LEVEL2 / LEVEL2
Interposer-Riser	LEVEL8 / LEVEL7	LEVEL7 / LEVEL6	LEVEL7 / LEVEL6	LEVEL6 / LEVEL5	LEVEL6 / LEVEL5	LEVEL5 / LEVEL3	LEVEL4 / LEVEL2	LEVEL3 / LEVEL2
Riser 2	LEVEL8 / LEVEL8	LEVEL7 / LEVEL7	LEVEL7 / LEVEL7	LEVEL6 / LEVEL6	LEVEL6 / LEVEL5	LEVEL5 / LEVEL3	LEVEL4 / LEVEL2	LEVEL2 / LEVEL2
2.5" PCIe NVMe SSD	2.5" PCIe NVMe SSD Support							
NVMe TDP = 25W, Rated to 70C	●●	●●	●●	●●	●●	●●	●●	●●
GPGPU card type	GPGPU card Support							
Nvidia Tesla A2 - LP- 60W	●-	●-	-	-	-	-	-	-
Intel ATS M3 - LP- 75W	●-	●-	●-	●-	●-	●-	-	-
PSU	PSU Support (Fan normal: 205W / Fan fail: 125W)							

Intel® Server M50FCP1UR212, 1U, Air-cooled								
Max Ambient Temperature	15°C	20°C	25°C	27°C	32°C	35°C	40°C	45°C
1600W	••	••	••	••	••	••	○ -	-
1300W	••	••	••	••	••	••	○ -	-
OCP V3	OCP V3 Support							
OCP 25W w/ class-2 QSFP	-	-	-	-	-	-	-	-
OCP 15W w/ class-2 QSFP	••	••	••	••	••	••	-	-
Battery Backup	Battery Support							
BBU, Rated to 45C	••	••	••	••	••	••	• -	-

Table 35. Thermal Configuration Matrix with Dual 5th Gen Processor Installed – Normal Operating Mode/Fan Fail mode (M50FCP1UR204)

Intel® Server M50FCP1UR204, EVAC, Air-cooled								
Max Ambient Temperature	15°C	20°C	25°C	27°C	32°C	35°C	40°C	45°C
CPU SKU	CPU Support (TDP350W)							
Intel® Xeon® Platinum 8592+, 350W, 64C	●●	●●	●●	●●	●○	○-	○-	-
Intel® Xeon® Platinum 8580, 350W, 60C	●●	●●	●●	●●	●○	○-	○-	-
Intel® Xeon® Platinum 8570, 350W, 56C	●●	●●	●●	●●	●○	○-	○-	-
Intel® Xeon® Platinum 8558P, 350W, 48C	●●	●●	●●	●●	●○	○-	○-	-
Intel® Xeon® Platinum 8568Y+, 350W, 48C	●●	●●	●●	●●	●○	○-	○-	-
Intel® Xeon® Platinum 8592V, 330W, 64C	●●	●●	●●	●●	●○	○-	-	-
Intel® Xeon® Platinum 8558, 330W, 48C	●●	●●	●●	●●	●○	○○	○-	-
Intel® Xeon® Platinum 8571N, 300W, 52C	●●	●●	●●	●●	●○	●○	○-	-
Intel® Xeon® Platinum 8558U, 300W, 48C	●●	●●	●●	●●	●○	●○	○-	-
Intel® Xeon® Platinum 8581V, 270W, 60C	●●	●●	●●	●●	●○	●○	○-	-
Intel® Xeon® Gold 6544S, 270W, 36C	●●	●●	●●	●●	●○	●○	○-	-
Intel® Xeon® Gold 6530, 270W, 32C	●●	●●	●●	●●	●○	●○	○○	-
Intel® Xeon® Platinum 8562Y+, 32C	●●	●●	●●	●●	●○	○○	-	-
Intel® Xeon® Gold 6544Y, 270W, 16C	●●	●●	●●	●●	●○	○○	○○	-
Intel® Xeon® Gold 6548Y+, 250W, 32C	●●	●●	●●	●●	●●	●●	●○	○-
Intel® Xeon® Gold 6548N, 250W, 32C	●●	●●	●●	●●	●●	●●	●○	○-
Intel® Xeon® Gold 6542Y, 250W, 24C	●●	●●	●●	●●	●●	●●	●○	○-
Intel® Xeon® Gold 6538Y+, 225W, 32C	●●	●●	●●	●●	●●	●●	●○	○-
Intel® Xeon® Gold 6538N, 205W, 32C	●●	●●	●●	●●	●●	●-	●-	●--
Intel® Xeon® Gold 5520+, 205W, 28C	●●	●●	●●	●●	●●	●●	●-	●-
Intel® Xeon® Gold 6526Y, 195W, 16C	●●	●●	●●	●●	●●	●●	●-	●--
Intel® Xeon® Gold 6534, 195W, 8C	●●	●●	●●	●●	●○	○○	○○	-

Intel® Server System M50FCP1UR Technical Product Specification

Intel® Xeon® Gold 5512U, 185W, 28C	●●	●●	●●	●●	●●	●●	●●	●-
Intel® Xeon® Gold 4516Y, 185W, 28C	●●	●●	●●	●●	●●	●-	●-	●-
Intel® Xeon® Gold 5515+, 165W, 8C	●●	●●	●●	●●	●●	●●	●-	●-
Intel® Xeon® Gold 4514Y, 150W, 16C	●●	●●	●●	●●	●●	●●	●●	●●
Intel® Xeon® Silver 4510, 150W, 12C	●●	●●	●●	●●	●●	●●	●●	●●
Memory Type	Memory Support							
DDR5, DRx8, 1x, 1DPC	●●	●●	●●	●●	●●	●●	●●	●●
DDR5, DRx4, 1x, 1DPC	●●	●●	●●	●●	●○	●○	●○	○○
DDR5, QRx4, 1x, 1DPC	●●	●●	●○	●○	●○	●○	○○	-
DDR5, DRx8, 1x, 2DPC	●●	●●	●●	●●	●●	●●	●●	●●
DDR5, DRx4, 1x, 2DPC	●●	●●	●●	●●	●●	●●	●●	●●
DDR5, QRx4, 1x, 2DPC	●●	●●	●●	●●	●●	●●	●●	●○
DDR5, DRx8, 2x, 1DPC	●●	●●	●●	●●	●●	●●	●●	●●
DDR5, DRx4, 2x, 1DPC	●●	●●	●●	●●	●●	●●	●○	●○
DDR5, QRx4, 2x, 1DPC	●●	●●	●●	●●	●○	●○	●○	○○
DDR5, DRx8, 2x, 2DPC	●●	●●	●●	●●	●●	●●	●●	●●
DDR5, DRx4, 2x, 2DPC	●●	●●	●●	●●	●●	●●	●●	●●
DDR5, QRx4, 2x, 2DPC	●●	●●	●●	●●	●●	●●	●●	●●
PCI Card Cooling	Supported Thermal Level							
Riser 1	LEVEL8 / LEVEL8	LEVEL8 / LEVEL8	LEVEL8 / LEVEL7	LEVEL8 / LEVEL7	LEVEL7 / LEVEL5	LEVEL7 / LEVEL5	LEVEL5 / LEVEL3	LEVEL3 / LEVEL2
Interposer-Riser	LEVEL8 / LEVEL8	LEVEL8 / LEVEL8	LEVEL8 / LEVEL7	LEVEL7 / LEVEL6	LEVEL7 / LEVEL6	LEVEL6 / LEVEL5	LEVEL5 / LEVEL4	LEVEL5 / LEVEL3
Riser 2	LEVEL8 / LEVEL8	LEVEL8 / LEVEL8	LEVEL8 / LEVEL7	LEVEL8 / LEVEL7	LEVEL7 / LEVEL6	LEVEL7 / LEVEL5	LEVEL5 / LEVEL3	LEVEL4 / LEVEL2
2.5" PCIe NVMe SSD	2.5" PCIe NVMe SSD Support							
NVMe TDP = 25W, Rated to 70C	●●	●●	●●	●●	●●	●●	●●	●●

GPGPU card type	GPGPU card Support							
Nvidia Tesla A2 - LP- 60W	● -	● -	● -	● -	-	-	-	-
Intel ATS M3 - LP- 75W	● -	● -	● -	● -	● -	● -	-	-
PSU	PSU Support (Fan normal: 205W / Fan fail: 250W)							
1600W	● ●	● ●	● ●	● ●	● ●	● ●	○ -	-
1300W	● ●	● ●	● ●	● ●	● ●	● ●	○ -	-
OCP V3	OCP V3 Support							
OCP 25W w/ class-2 QSFP	● ●	● ●	● ●	● ●	● -	● -	-	-
OCP 15W w/ class-2 QSFP	● ●	● ●	● ●	● ●	● ●	● ●	-	-
Battery Backup	Battery Support							
BBU, Rated to 45C	● ●	● ●	● ●	● ●	● ●	● ●	● -	-

Table 36. Thermal Configuration Matrix with Dual 5th Gen Processor Installed – Normal Operating Mode/Fan Fail mode (M50FCP1UR212)

Intel® Server M50FCP1UR212, 1U, Air-cooled								
Max Ambient Temperature	15°C	20°C	25°C	27°C	32°C	35°C	40°C	45°C
CPU SKU	CPU Support (TDP350W)							
Intel® Xeon® Gold 6538N, 205W, 32C	●●	●●	●-	●-	●-	●-	-	-
Intel® Xeon® Gold 5520+, 205W, 28C	●●	●●	●-	●-	●-	●-	-	-
Intel® Xeon® Gold 6526Y, 195W, 16C	●●	●●	●-	●-	●-	●-	-	-
Intel® Xeon® Gold 6534, 195W, 8C	●○	○○	○-	-	-	-	-	-
Intel® Xeon® Gold 5512U, 185W, 28C	●●	●●	●●	●-	●-	●-	●-	-
Intel® Xeon® Silver 4516Y+, 185W, 24C	●●	●●	●●	●-	●-	●-	○-	-
Intel® Xeon® Gold 5515+, 165W, 8C	●●	●●	●●	●●	●-	●-	○-	-
Intel® Xeon® Gold 4514Y, 150W, 16C	●●	●●	●●	●●	●●	●-	●-	-
Intel® Xeon® Silver 4510, 150W, 12C	●●	●●	●●	●●	●●	●-	●-	-
Memory Type	Memory Support							
DDR5, DRx8, 1x, 1DPC	●●	●●	●●	●●	●●	●●	●○	●○
DDR5, DRx4, 1x, 1DPC	●●	●○	●○	●○	●○	○○	○○	-
DDR5, QRx4, 1x, 1DPC	●○	●○	●○	●○	○○	-	-	-
DDR5, DRx8, 1x, 2DPC	●●	●●	●●	●●	●●	●●	●●	●●
DDR5, DRx4, 1x, 2DPC	●●	●●	●●	●●	●●	●●	●●	●○
DDR5, QRx4, 1x, 2DPC	●●	●●	●●	●●	●●	●○	●○	●○
DDR5, DRx8, 2x, 1DPC	●●	●●	●●	●●	●●	●●	●●	●●
DDR5, DRx4, 2x, 1DPC	●●	●●	●○	●○	●○	●○	●○	○○
DDR5, QRx4, 2x, 1DPC	●○	●○	●○	●○	●○	○○	○○	-
DDR5, DRx8, 2x, 2DPC	●●	●●	●●	●●	●●	●●	●●	●●
DDR5, DRx4, 2x, 2DPC	●●	●●	●●	●●	●●	●●	●●	●●
DDR5, QRx4, 2x, 2DPC	●●	●●	●●	●●	●●	●●	●○	●○

Intel® Server M50FCP1UR212, 1U, Air-cooled								
PCI Card Cooling	Supported Thermal Level							
Riser 1	LEVEL8 / LEVEL7	LEVEL7 / LEVEL6	LEVEL7 / LEVEL6	LEVEL6 / LEVEL5	LEVEL6 / LEVEL5	LEVEL5 / LEVEL3	LEVEL4 / LEVEL2	LEVEL2 / LEVEL2
Interposer-Riser	LEVEL8 / LEVEL7	LEVEL7 / LEVEL6	LEVEL7 / LEVEL6	LEVEL6 / LEVEL5	LEVEL6 / LEVEL5	LEVEL5 / LEVEL3	LEVEL4 / LEVEL2	LEVEL3 / LEVEL2
Riser 2	LEVEL8 / LEVEL8	LEVEL7 / LEVEL7	LEVEL7 / LEVEL7	LEVEL6 / LEVEL6	LEVEL6 / LEVEL5	LEVEL5 / LEVEL3	LEVEL4 / LEVEL2	LEVEL2 / LEVEL2
2.5" PCIe NVMe SSD	2.5" PCIe NVMe SSD Support							
NVMe TDP = 25W, Rated to 70C	••	••	••	••	••	••	••	••
GPGPU card type	GPGPU card Support							
Nvidia Tesla A2 - LP- 60W	•-	•-	-	-	-	-	-	-
Intel ATS M3 - LP- 75W	•-	•-	•-	•-	•-	•-	-	-
PSU	PSU Support (Fan normal: 205W / Fan fail: 250W)							
1600W	••	••	••	••	••	••	○-	-
1300W	••	••	••	••	••	••	○-	-
OCP V3	OCP V3 Support							
OCP 25W w/ class-2 QSFP	-	-	-	-	-	-	-	-
OCP 15W w/ class-2 QSFP	••	••	••	••	••	••	-	-
Battery Backup	Battery Support							
BBU, Rated to 45C	••	••	••	••	••	••	•-	-

C.2 Normal Operating Mode/Fan Fail Mode with Single Processor Installed

Table 37. Thermal Configuration Matrix with Single 4th Gen Processor Installed – Normal Operating Mode/Fan Fail Mode (M50FCP1UR204)

Intel® Server M50FCP1UR204, 1U, Single Processor, EVAC, Air-cooled								
Max Ambient Temperature	15°C	20°C	25°C	27°C	32°C	35°C	40°C	45°C
CPU SKU	CPU Support (TDP 250W)							
Intel® Xeon® Gold 6414U, 250W, 32C	● -	● -	● -	● -	● -	● -	● -	-
Intel® Xeon® Platinum 8450H, 250W, 28C	● -	● -	● -	● -	● -	● -	● -	-
Intel® Xeon® Gold 6448H, 250W, 32C	● -	● -	● -	● -	● -	● -	● -	-
Intel® Xeon® Gold 6448Y, 225W, 32C	● -	● -	● -	● -	● -	● -	● -	-
Intel® Xeon® Gold 6442Y, 225W, 24C	● -	● -	● -	● -	● -	● -	● -	-
Intel® Xeon® Gold 6438M, 205W, 32C	● -	● -	● -	● -	● -	● -	● -	-
Intel® Xeon® Gold 6438N, 205W, 32C	● -	● -	● -	● -	● -	● -	● -	-
Intel® Xeon® Gold 6438Y+, 205W, 32C	● -	● -	● -	● -	● -	● -	● -	-
Intel® Xeon® Gold 5420+, 205W, 28C	● -	● -	● -	● -	● -	● -	● -	-
Intel® Xeon® Gold 6434, 195W, 8C	● -	● -	● -	● -	● -	○ -	○ -	-
Intel® Xeon® Gold 6434H, 195W, 8C	● -	● -	● -	● -	● -	○ -	○ -	-
Intel® Xeon® Gold 6428N, 185W, 32C	● -	● -	● -	● -	● -	● -	● -	● -
Intel® Xeon® Gold 6421N, 185W, 32C	● -	● -	● -	● -	● -	● -	● -	● -
Intel® Xeon® Gold 5418Y, 185W, 24C	● -	● -	● -	● -	● -	● -	● -	● -
Intel® Xeon® Gold 6418H, 185W, 24C	● -	● -	● -	● -	● -	● -	● -	● -
Intel® Xeon® Gold 5412U, 185W, 24C	● -	● -	● -	● -	● -	● -	● -	● -
Intel® Xeon® Gold 6426Y, 185W, 16C	● -	● -	● -	● -	● -	● -	● -	● -
Intel® Xeon® Gold 5418N, 165W, 24C	● -	● -	● -	● -	● -	● -	● -	● -
Intel® Xeon® Gold 5411N, 165W, 24C	● -	● -	● -	● -	● -	● -	● -	● -
Intel® Xeon® Silver 4416+, 165W, 20C	● -	● -	● -	● -	● -	● -	● -	● -
Intel® Xeon® Gold 6416H, 165W, 18C	● -	● -	● -	● -	● -	● -	● -	● -

Intel® Server System M50FCP1UR Technical Product Specification

Intel® Xeon® Gold 5416S, 150W, 16C	● -	● -	● -	● -	● -	● -	● -	● -
Intel® Xeon® Silver 4410Y, 150W, 12C	● -	● -	● -	● -	● -	● -	● -	● -
Intel® Xeon® Gold 5415+, 150W, 8C	● -	● -	● -	● -	● -	● -	● -	● -
Intel® Xeon® Bronze 3408U, 125W, 8C	● -	● -	● -	● -	● -	● -	● -	● -
Intel® Xeon® Silver 4410T, 150W, 10C	● -	● -	● -	● -	● -	● -	● -	● -
Memory Type	Memory Support							
DDR5, DRx8, 1x, 1DPC	● -	● -	● -	● -	● -	● -	● -	● -
DDR5, DRx4, 1x, 1DPC	● -	● -	● -	● -	● -	● -	● -	○ -
DDR5, QRx4, 1x, 1DPC	● -	● -	● -	● -	● -	○ -	○ -	-
DDR5, DRx8, 1x, 2DPC	● -	● -	● -	● -	● -	● -	● -	● -
DDR5, DRx4, 1x, 2DPC	● -	● -	● -	● -	● -	● -	● -	● -
DDR5, QRx4, 1x, 2DPC	● -	● -	● -	● -	● -	● -	● -	● -
DDR5, DRx8, 2x, 1DPC	● -	● -	● -	● -	● -	● -	● -	● -
DDR5, DRx4, 2x, 1DPC	● -	● -	● -	● -	● -	● -	● -	● -
DDR5, QRx4, 2x, 1DPC	● -	● -	● -	● -	● -	● -	● -	○ -
DDR5, DRx8, 2x, 2DPC	● -	● -	● -	● -	● -	● -	● -	● -
DDR5, DRx4, 2x, 2DPC	● -	● -	● -	● -	● -	● -	● -	● -
DDR5, QRx4, 2x, 2DPC	● -	● -	● -	● -	● -	● -	● -	● -
PCI Card Cooling	Supported Thermal Level							
Riser 1	LEVEL8 / -	LEVEL7 / -	LEVEL5 / -	LEVEL5 / -	LEVEL3 / -	LEVEL2 / -	LEVEL1 / -	LEVEL1 / -
Interposer-Riser	N/A	N/A	N/A	N/A	N/A	N/A	N/A	N/A
Riser 2	N/A	N/A	N/A	N/A	N/A	N/A	N/A	N/A
2.5" PCIe NVMe SSD	2.5" PCIe NVMe SSD Support							
NVMe TDP = 25W, Rated to 70C	● -	● -	● -	● -	● -	● -	● -	● -
GPGPU card type	GPGPU card Support							

Nvidia Tesla A2 - LP- 60W	●-	●-	●-	●-	-	-	-	-
Intel ATS M3 - LP- 75W	●-	●-	●-	●-	●-	●-	-	-
PSU	PSU Support (CPU power: 250W)							
1600W	●-	●-	●-	●-	●-	●-	●-	-
1300W	●-	●-	●-	●-	●-	●-	●-	-
OCP V3	OCP V3 Support							
OCP 25W w/ class-2 QSFP	●-	●-	●-	●-	●-	●-	-	-
OCP 15W w/ class-2 QSFP	●-	●-	●-	●-	●-	●-	-	-
Battery Backup	Battery Support							
BBU, Rated to 45C	●-	●-	●-	●-	●-	●-	●-	-

Table 38. Thermal Configuration Matrix with Single 4th Gen Processor Installed – Normal Operating Mode/Fan Fail Mode (M50FCP1UR212)

Intel® Server M50FCP1UR212, Single Processor, Air-cooled								
Max Ambient Temperature	15°C	20°C	25°C	27°C	32°C	35°C	40°C	45°C
CPU SKU	CPU Support (TDP 125W)							
Intel® Xeon® Bronze 3408U, 125W, 8C	● -	● -	● -	● -	● -	● -	● -	-
Memory Type	Memory Support							
DDR5, DRx8, 1x, 1DPC	● -	● -	● -	● -	● -	● -	● -	● -
DDR5, DRx4, 1x, 1DPC	● -	● -	● -	● -	● -	○ -	-	-
DDR5, QRx4, 1x, 1DPC	● -	● -	● -	○ -	○ -	-	-	-
DDR5, DRx8, 1x, 2DPC	● -	● -	● -	● -	● -	● -	● -	● -
DDR5, DRx4, 1x, 2DPC	● -	● -	● -	● -	● -	● -	● -	● -
DDR5, QRx4, 1x, 2DPC	● -	● -	● -	● -	● -	● -	● -	○ -
DDR5, DRx8, 2x, 1DPC	● -	● -	● -	● -	● -	● -	● -	● -
DDR5, DRx4, 2x, 1DPC	● -	● -	● -	● -	● -	● -	● -	○ -
DDR5, QRx4, 2x, 1DPC	● -	● -	● -	● -	● -	○ -	-	-
DDR5, DRx8, 2x, 2DPC	● -	● -	● -	● -	● -	● -	● -	● -
DDR5, DRx4, 2x, 2DPC	● -	● -	● -	● -	● -	● -	● -	● -
DDR5, QRx4, 2x, 2DPC	● -	● -	● -	● -	● -	● -	● -	● -
PCI Card Cooling	Supported Thermal Level							
Riser 1	LEVEL8 / -	LEVEL7 / -	LEVEL6 / -	LEVEL6 / -	LEVEL5 / -	LEVEL5 / -	LEVEL3 / -	LEVEL2 / -
Interposer-Riser	N/A	N/A	N/A	N/A	N/A	N/A	N/A	N/A
Riser 2	N/A	N/A	N/A	N/A	N/A	N/A	N/A	N/A
2.5" PCIe NVMe SSD	2.5" PCIe NVMe SSD Support							
NVMe TDP = 25W, Rated to 70C	● -	● -	● -	● -	● -	● -	● -	● -
GPGPU card type	GPGPU card Support							

Intel® Server M50FCP1UR212, Single Processor, Air-cooled								
Max Ambient Temperature	15°C	20°C	25°C	27°C	32°C	35°C	40°C	45°C
Nvidia Tesla A2 - LP- 60W	● -	● -	-	-	-	-	-	-
Intel ATS M3 - LP- 75W	● -	● -	● -	● -	● -	● -	-	-
PSU	PSU Support (CPU power: 125W)							
1600W	● -	● -	● -	● -	● -	● -	● -	-
1300W	● -	● -	● -	● -	● -	● -	● -	-
OCP V3	OCP V3 Support							
OCP 25W w/ class-2 QSFP	-	-	-	-	-	-	-	-
OCP 15W w/ class-2 QSFP	● -	● -	● -	● -	● -	● -	-	-
Battery Backup	Battery Support							
BBU, Rated to 45C	● -	● -	● -	● -	● -	● -	● -	-

Table 39. Thermal Configuration Matrix with Single 5th Gen Processor Installed – Normal Operating Mode/Fan Fail Mode (M50FCP1UR204)

Intel® Server M50FCP1UR204, 1U EVAC, Single Processor, Air-cooled								
Max Ambient Temperature	15°C	20°C	25°C	27°C	32°C	35°C	40°C	45°C
CPU SKU	CPU Support (TDP 250W)							
Intel® Xeon® Gold 6548Y+, 250W, 32C	● -	● -	● -	● -	● -	● -	● -	-
Intel® Xeon® Gold 6548N, 250W, 32C	● -	● -	● -	● -	● -	● -	● -	-
Intel® Xeon® Gold 6542Y, 250W, 24C	● -	● -	● -	● -	● -	● -	● -	-
Intel® Xeon® Gold 6538Y+, 225W, 32C	● -	● -	● -	● -	● -	● -	● -	-
Intel® Xeon® Gold 6538N, 205W, 32C	● -	● -	● -	● -	● -	● -	● -	-
Intel® Xeon® Gold 5520+, 205W, 28C	● -	● -	● -	● -	● -	● -	● -	-
Intel® Xeon® Gold 6526Y, 195W, 16C	● -	● -	● -	● -	● -	● -	● -	● -
Intel® Xeon® Gold 6534, 195W, 8C	● -	● -	● -	● -	● -	○ -	-	-
Intel® Xeon® Gold 5512U, 185W, 28C	● -	● -	● -	● -	● -	● -	● -	● -
Intel® Xeon® Silver 4516Y+, 185W, 24C	● -	● -	● -	● -	● -	● -	● -	● -
Intel® Xeon® Silver 4510, 150W, 12C	● -	● -	● -	● -	● -	● -	● -	● -
Intel® Xeon® Gold 5515+, 165W, 8C	● -	● -	● -	● -	● -	● -	● -	● -
Intel® Xeon® Gold 4514Y, 150W, 16C	● -	● -	● -	● -	● -	● -	● -	● -
Memory Type	Memory Support							
DDR5, DRx8, 1x, 1DPC	● -	● -	● -	● -	● -	● -	● -	● -
DDR5, DRx4, 1x, 1DPC	● -	● -	● -	● -	● -	● -	● -	○ -
DDR5, QRx4, 1x, 1DPC	● -	● -	● -	● -	● -	○ -	○ -	-
DDR5, DRx8, 1x, 2DPC	● -	● -	● -	● -	● -	● -	● -	● -
DDR5, DRx4, 1x, 2DPC	● -	● -	● -	● -	● -	● -	● -	● -
DDR5, QRx4, 1x, 2DPC	● -	● -	● -	● -	● -	● -	● -	● -
DDR5, DRx8, 2x, 1DPC	● -	● -	● -	● -	● -	● -	● -	● -
DDR5, DRx4, 2x, 1DPC	● -	● -	● -	● -	● -	● -	● -	● -

Intel® Server M50FCP1UR204, 1U EVAC, Single Processor, Air-cooled								
Max Ambient Temperature	15°C	20°C	25°C	27°C	32°C	35°C	40°C	45°C
DDR5, QRx4, 2x, 1DPC	● -	● -	● -	● -	● -	● -	● -	○ -
DDR5, DRx8, 2x, 2DPC	● -	● -	● -	● -	● -	● -	● -	● -
DDR5, DRx4, 2x, 2DPC	● -	● -	● -	● -	● -	● -	● -	● -
DDR5, QRx4, 2x, 2DPC	● -	● -	● -	● -	● -	● -	● -	● -
PCI Card Cooling	Supported Thermal Level							
Riser 1	LEVEL8 / -	LEVEL7 / -	LEVEL5 / -	LEVEL5 / -	LEVEL3 / -	LEVEL2 / -	LEVEL1 / -	LEVEL1 / -
Interposer-Riser	N/A	N/A	N/A	N/A	N/A	N/A	N/A	N/A
Riser 2	N/A	N/A	N/A	N/A	N/A	N/A	N/A	N/A
2.5" PCIe NVMe SSD	2.5" PCIe NVMe SSD Support							
NVMe TDP = 25W, Rated to 70C	● -	● -	● -	● -	● -	● -	● -	● -
GPGPU card type	GPGPU card Support							
Nvidia Tesla A2 - LP- 60W	● -	● -	● -	● -	-	-	-	-
Intel ATS M3 - LP- 75W	● -	● -	● -	● -	● -	● -	-	-
PSU	PSU Support (CPU power: 250W)							
1600W	● -	● -	● -	● -	● -	● -	● -	-
1300W	● -	● -	● -	● -	● -	● -	● -	-
OCP V3	OCP V3 Support							
OCP 25W w/ class-2 QSFP	● -	● -	● -	● -	● -	● -	-	-
OCP 15W w/ class-2 QSFP	● -	● -	● -	● -	● -	● -	-	-
Battery Backup	Battery Support							
BBU, Rated to 45C	● -	● -	● -	● -	● -	● -	● -	-

Table 40. Thermal Configuration Matrix with Single 5th Gen Processor Installed – Normal Operating Mode/Fan Fail Mode (M50FCP1UR212)

Intel® Server M50FCP1UR212, Single processor, Air-cooled								
Max Ambient Temperature	15°C	20°C	25°C	27°C	32°C	35°C	40°C	45°C
CPU SKU	CPU Support							
Intel® Xeon® Platinum 8592+, 350W, 64C	-	-	-	-	-	-	-	-
Intel® Xeon® Platinum 8580Q, 350W, 60C (LC)	-	-	-	-	-	-	-	-
Intel® Xeon® Platinum 8580, 350W, 60C	-	-	-	-	-	-	-	-
Intel® Xeon® Platinum 8570, 350W, 56C	-	-	-	-	-	-	-	-
Intel® Xeon® Platinum 8558P, 350W, 48C	-	-	-	-	-	-	-	-
Intel® Xeon® Platinum 8568Y+, 350W, 48C	-	-	-	-	-	-	-	-
Intel® Xeon® Platinum 8592V, 330W, 64C	-	-	-	-	-	-	-	-
Intel® Xeon® Platinum 8558, 330W, 48C	-	-	-	-	-	-	-	-
Intel® Xeon® Platinum 8571N, 300W, 52C	-	-	-	-	-	-	-	-
Intel® Xeon® Platinum 8558U, 300W, 48C	-	-	-	-	-	-	-	-
Intel® Xeon® Platinum 8581V, 270W, 60C	-	-	-	-	-	-	-	-
Intel® Xeon® Gold 6554S, 270W, 36C	-	-	-	-	-	-	-	-
Intel® Xeon® Gold 6530, 270W, 32C	-	-	-	-	-	-	-	-
Intel® Xeon® Gold 6558Q, 350W, 32C (LC)	-	-	-	-	-	-	-	-
Intel® Xeon® Platinum 8562Y+, 300W, 32C	-	-	-	-	-	-	-	-
Intel® Xeon® Gold 6544Y, 270W, 16C	-	-	-	-	-	-	-	-
Intel® Xeon® Gold 6548Y+, 250W, 32C	-	-	-	-	-	-	-	-
Intel® Xeon® Gold 6548N, 250W, 32C	-	-	-	-	-	-	-	-
Intel® Xeon® Gold 6542Y, 250W, 24C	-	-	-	-	-	-	-	-
Intel® Xeon® Gold 6538Y+, 225W, 32C	-	-	-	-	-	-	-	-
Intel® Xeon® Gold 6538N, 205W, 32C	-	-	-	-	-	-	-	-
Intel® Xeon® Gold 5520+, 205W, 28C	-	-	-	-	-	-	-	-

Intel® Server M50FCP1UR212, Single processor, Air-cooled								
Max Ambient Temperature	15°C	20°C	25°C	27°C	32°C	35°C	40°C	45°C
Intel® Xeon® Gold 6526Y, 195W, 16C	-	-	-	-	-	-	-	-
Intel® Xeon® Gold 6534, 195W, 8C	-	-	-	-	-	-	-	-
Intel® Xeon® Gold 5512U, 185W, 28C	-	-	-	-	-	-	-	-
Intel® Xeon® Silver 4516Y+, 185W, 24C	-	-	-	-	-	-	-	-
Intel® Xeon® Gold 5515+, 165W, 8C	-	-	-	-	-	-	-	-
Intel® Xeon® Gold 4514Y, 150W, 16C	-	-	-	-	-	-	-	-
Intel® Xeon® Silver 4510, 150W, 12C	-	-	-	-	-	-	-	-
Memory Type	Memory Support							
DDR5, DRx8, 1x, 1DPC	●-	●-	●-	●-	●-	●-	●-	●-
DDR5, DRx4, 1x, 1DPC	●-	●-	●-	●-	●-	○-	-	-
DDR5, QRx4, 1x, 1DPC	●-	●-	●-	○-	○-	-	-	-
DDR5, DRx8, 1x, 2DPC	●-	●-	●-	●-	●-	●-	●-	●-
DDR5, DRx4, 1x, 2DPC	●-	●-	●-	●-	●-	●-	●-	●-
DDR5, QRx4, 1x, 2DPC	●-	●-	●-	●-	●-	●-	●-	○-
DDR5, DRx8, 2x, 1DPC	●-	●-	●-	●-	●-	●-	●-	●-
DDR5, DRx4, 2x, 1DPC	●-	●-	●-	●-	●-	●-	●-	○-
DDR5, QRx4, 2x, 1DPC	●-	●-	●-	●-	●-	○-	-	-
DDR5, DRx8, 2x, 2DPC	●-	●-	●-	●-	●-	●-	●-	●-
DDR5, DRx4, 2x, 2DPC	●-	●-	●-	●-	●-	●-	●-	●-
DDR5, QRx4, 2x, 2DPC	●-	●-	●-	●-	●-	●-	●-	●-
PCI Card Cooling	Supported Thermal Level							
Riser 1	LEVEL8 / -	LEVEL7 / -	LEVEL6 / -	LEVEL6 / -	LEVEL5 / -	LEVEL5 / -	LEVEL3 / -	LEVEL2 / -
Interposer-Riser	N/A	N/A	N/A	N/A	N/A	N/A	N/A	N/A

Intel® Server M50FCP1UR212, Single processor, Air-cooled								
Max Ambient Temperature	15°C	20°C	25°C	27°C	32°C	35°C	40°C	45°C
Riser 2	N/A	N/A	N/A	N/A	N/A	N/A	N/A	N/A
2.5" PCIe NVMe SSD	2.5" PCIe NVMe SSD Support							
NVMe TDP = 25W, Rated to 70C	● -	● -	● -	● -	● -	● -	● -	● -
GPGPU card type	GPGPU card Support							
Nvidia Tesla A2 - LP- 60W	● -	● -	-	-	-	-	-	-
Intel ATS M3 - LP- 75W	● -	● -	● -	● -	● -	● -	-	-
PSU	PSU Support (CPU power: 125W)							
1600W	-	-	-	-	-	-	-	-
1300W	-	-	-	-	-	-	-	-
OCP V3	OCP V3 Support							
OCP 25W w/ class-2 QSFP	-	-	-	-	-	-	-	-
OCP 15W w/ class-2 QSFP	● -	● -	● -	● -	● -	● -	-	-
Battery Backup	Battery Support							
BBU, Rated to 45C	● -	● -	● -	● -	● -	● -	● -	-

Appendix E. System Sensors

The following figures provide the location of the sensors within the Intel® Server System M50FCP1UR.

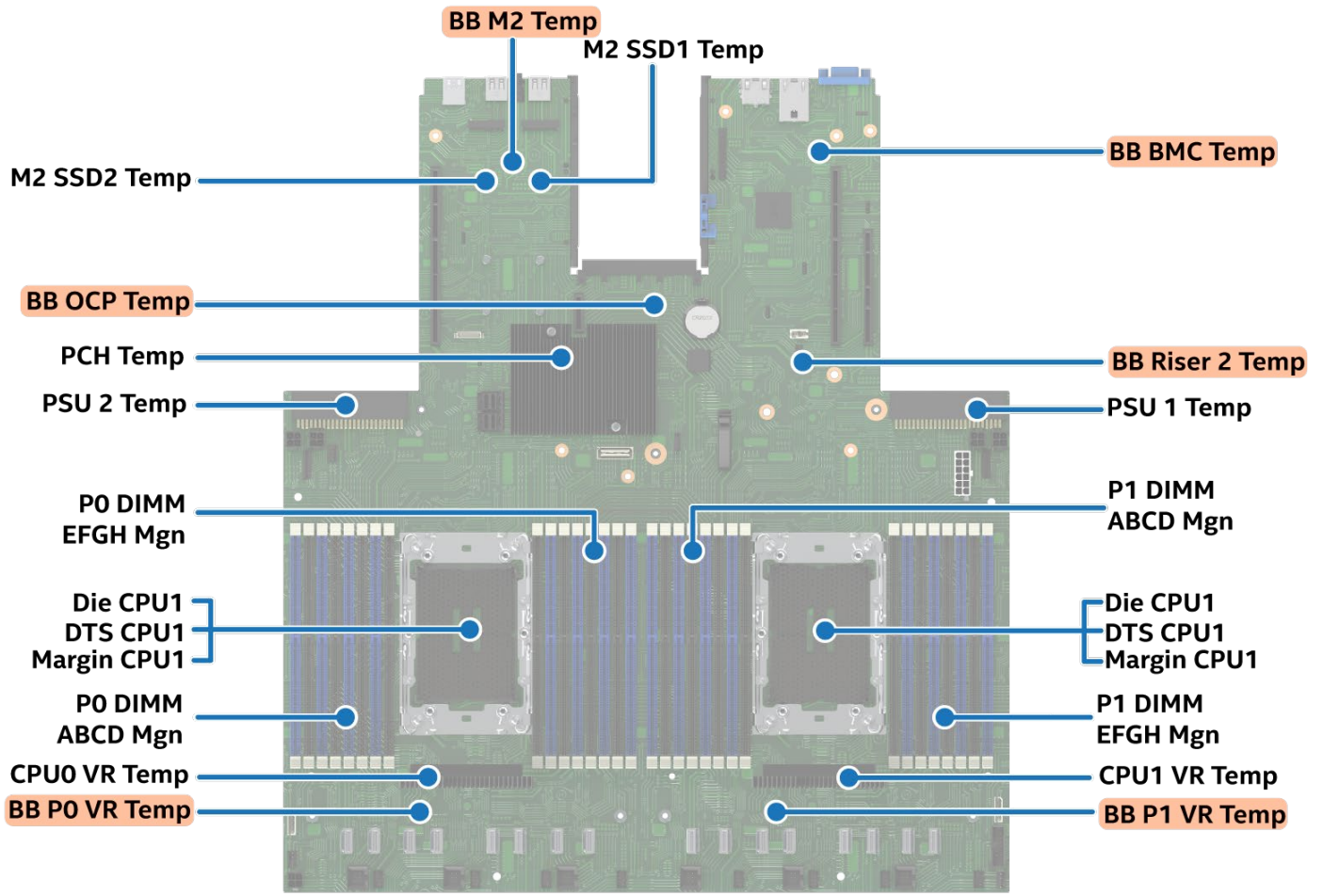

Ref #: FCP40880

Figure 91. Server Board Sensor Map

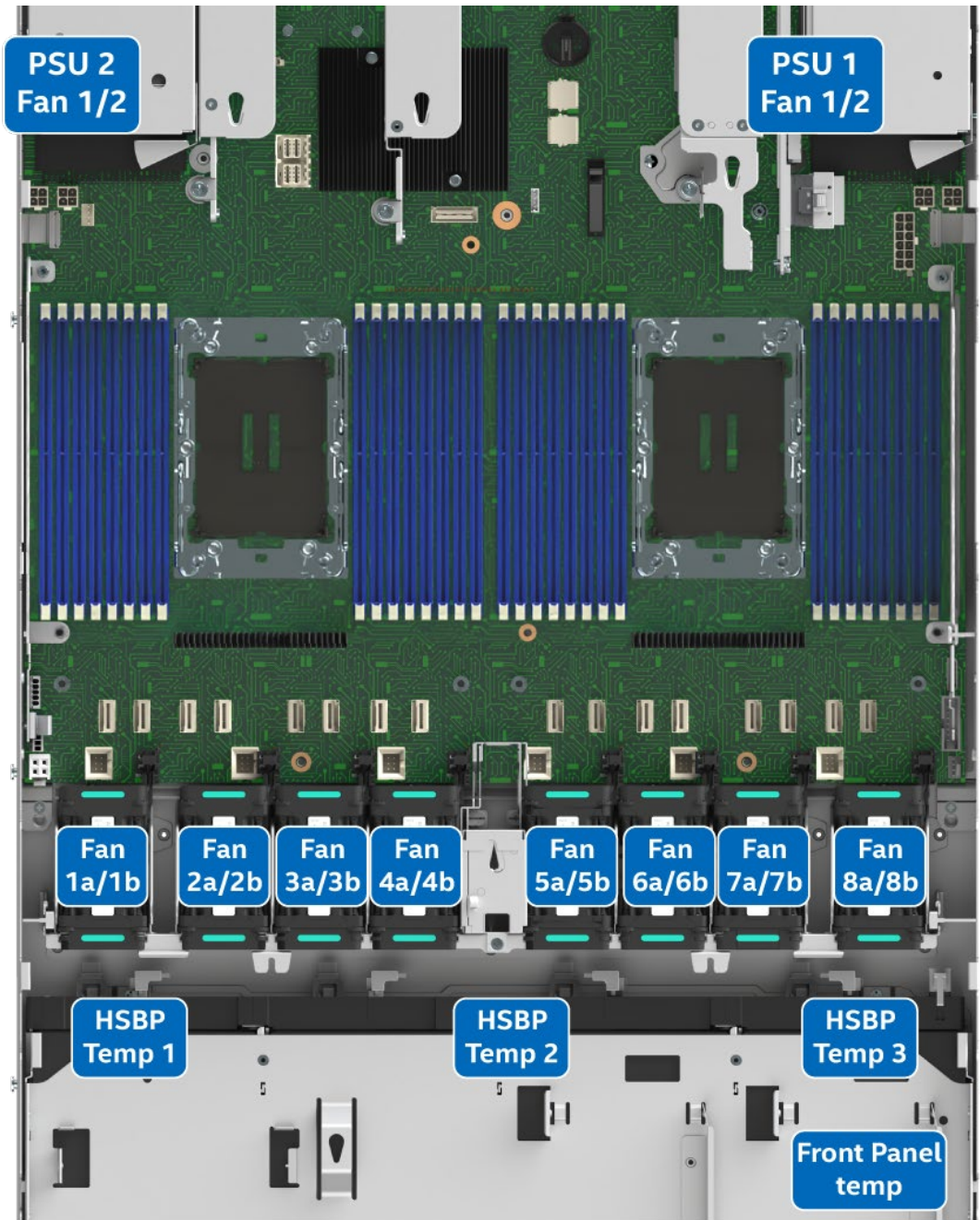

Ref #: FCP40900

Figure 92. Server System Sensor Map

Appendix F. Statement of Volatility

The tables in this section are used to identify the volatile and non-volatile memory components for system boards used within the Intel® Server System M50FCP1UR.

The tables provide the following data for each identified component.

- **Component Type:** Three types of components are on the server board assembly:
 - **Non-volatile:** Non-volatile memory is persistent and is not cleared when power is removed from the system. Non-volatile memory must be erased to clear data. The exact method of clearing these areas varies by the specific component. Some areas are required for normal operation of the server, and clearing these areas may render the server board inoperable
 - **Volatile:** Volatile memory is cleared automatically when power is removed from the system.
 - **Battery powered RAM:** Battery powered RAM is similar to volatile memory but is powered by a battery on the server board. Data in battery powered RAM is persistent until the battery is removed from the server board.
- **Size:** Size of each component in bits, kilobits (Kbits), megabits (Mbits), bytes, kilobytes (KB), or megabytes (MB).
- **Board Location:** Board location is the physical location of each component corresponding to information on the server board silkscreen.
- **User Data:** The flash components on the server boards do not store user data from the operating system. No operating system level data is retained in any listed components after AC power is removed. The persistence of information written to each component is determined by its type as described in the table.

Each component stores data specific to its function. Some components may contain passwords that provide access to that device's configuration or functionality. These passwords are specific to the device and are unique and unrelated to operating system passwords. The specific components that may contain password data are:

- **BIOS:** The BIOS for the server board provides the capability to prevent unauthorized users from configuring BIOS settings when a BIOS password is set. This password is stored in BIOS flash and is only used to set BIOS configuration access restrictions.
- **BMC:** The server boards support an Intelligent Platform Management Interface (IPMI) 2.0 conformant baseboard management controller (BMC). The BMC provides health monitoring, alerting and remote power control capabilities for the Intel server board. The BMC does not have access to operating system level data.

The BMC supports the capability for remote software to connect over the network and perform health monitoring and power control. This access can be configured to require authentication by a password. If configured, the BMC maintains user passwords to control this access. These passwords are stored in the BMC flash.

The Intel® Server System M50FCP1UR includes several components that can be used to store data. A list of those components is included in the following table.

Table 41. SOV – Server Board Components

Component Type	Size	Board Location	User Data	Name
Non-Volatile	64MB	U11	No	BIOS Flash
Non-Volatile	256MB	U19	No	BMC Flash
Non-Volatile	UFM 5,888 Kb M9K Memory 1,638 Kb	U1_FPGA	No	FPGA
Volatile	8Gb	U1_BMC	No	BMC SDRAM

System boards in the Intel® Server System M50FCP2UR may include components used to store data. The following tables provide a list of components associated with specific system boards supported by this family. For server board components, see the previous table.

Table 42. SOV – System Board Components

Component Type	Size	Board Location	User Data	Name
Non-Volatile	256 B	U9	No	RISER3_1U_2U_NVMe_CARD_AsteraLabs FRU
Non-Volatile	256 KB	U2	No	RISER3_1U_2U_NVMe_CARD_AsteraLabs EEPROM
Non-Volatile	256 B	U3_HF	No	FCP_2SLOT_2U_Riser1_DW FRU
Non-Volatile	256 B	U3_HF	No	FCP_2SLOT_2U_Riser2_DW FRU
Non-Volatile	256 B	U3	No	FCP_2SLOT_2U_Riser3 FRU
Non-Volatile	256 B	U101	No	FCP_1SLOT_1U_Riser1 FRU
Non-Volatile	256 B	U6	No	FCP_1SLOT_1U_Riser2 FRU
Non-Volatile	256 B	U2	No	FCP_3SLOT_2U_Riser1 FRU
Non-Volatile	256 B	U2	No	FCP_3SLOT_2U_Riser2 FRU
Non-Volatile	256 B	U5	No	FCP_1SLOT_1U_Riser2_wRT FRU
Non-Volatile	256 KB	U8	No	FCP_1SLOT_1U_Riser2_wRT EEPROM

System boards with an Intel server chassis contain components used to store data. A list of components for the system boards in the chassis is included in the following table. For server board components, see the previous tables.

Table 43. Server Chassis Components

Component Type	Size	Board Location	User Data	Name
Non-Volatile	256 B	U12	No	1U 4x2.5" Combo HSBP FRU
Non-Volatile	UFM 1,376 Kb M9K Memory 378 Kb	U2	No	1U 4X2.5" Combo HSBP FPGA
Non-Volatile	256 B	U12	No	1U12x2.5" Combo HSBP FRU
Non-Volatile	UFM 1,376 Kb M9K Memory 378 Kb	U1, U2	No	1U12x2.5" Combo HSBP FPGA

Appendix G. Product Regulatory Compliance

This product has been evaluated and certified as Information Technology Equipment (ITE), which may be installed in offices, schools, computer rooms, and similar commercial type locations. The suitability of this product for other product certification categories and/or environments (such as: medical, industrial, telecommunications, NEBS, residential, alarm systems, test equipment, and so on), other than an ITE application, will require further evaluation and may require additional regulatory approvals.

Intel has verified that all L3, L6, and L9 server products¹ **as configured and sold by Intel** to its customers comply with the requirements for all regulatory certifications defined in the following table. It is the Intel customer's responsibility to ensure their final server system configurations are tested and certified to meet the regulatory requirements for the countries to which they plan to ship and or deploy server systems into.

	Intel® Server System M50FCP1UR	Notes
	1U "Foxcreek Pass"	Intel Project Code Name
	L6/L9 System	Product integration level
	M500001UR	Product family identified on certification
Regulatory Certification		
RCM DoC Australia & New Zealand	✓	
CB Certification & Report (International - report to include all CB country national deviations)	✓	
China CCC Certification	○	Out of CCC Scope
CU Certification (Russia/Belarus/Kazakhstan)	○	
Europe CE Declaration of Conformity	✓	
FCC Part 15 Emissions Verification (USA & Canada)	✓	
Germany GS Certification	✓	
India BIS Certification	●	Only L9 at HOU
International Compliance – CISPR32 & CISPR35	✓	
Japan VCCI Certification	✓	
Korea KC Certification	✓	
Mexico Certification	✓	
NRTL Certification (USA&Canada)	✓	
South Africa Certification	✓	
Taiwan BSMI Certification	✓	
Ukraine Certification	○	

Table Key

Not Tested / Not Certified	○
Tested / Certified – Limited OEM SKUs only	●
Testing / Certification (Planned)	(Date)
Tested / Certified	✓

¹ An L9 system configuration is a power-on ready server system with NO operating system installed. An L6 system configuration requires additional components to be installed to make it power-on ready. L3 are component building block options that require integration into a chassis to create a functional server system.

EU Directive 2019/424 (Lot 9)

Beginning on March 1, 2020, an additional component of the European Union (EU) regulatory CE marking scheme, identified as EU Directive 2019/424 (Lot 9), will go into effect. After this date, all new server systems shipped into or deployed within the EU must meet the full CE marking requirements including those defined by the additional EU Lot 9 regulations.

Intel has verified that all L3, L6, and L9 server products² **as configured and sold by Intel** to its customers comply with the full CE regulatory requirements for the given product type, including those defined by EU Lot 9. **It is the Intel customer's responsibility to ensure their final server system configurations are SPEC® SERT™ tested and meet the new CE regulatory requirements.**

Visit the following website for additional EU Directive 2019/424 (Lot9) information:

<https://eur-lex.europa.eu/legal-content/EN/TXT/?uri=CELEX:32019R0424>

In compliance with the EU Directive 2019/424 (Lot 9) materials efficiency requirements, Intel makes available all necessary product collaterals as identified below:

- **System Disassembly Instructions**
 - *Intel® Server System M50FCP1UR Integration and Service Guide*
- **Product Specifications**
 - *Intel® Server System M50FCP1UR Technical Product Specification* (This document)
 - *Intel® Server Board M50FCP2SBSTD Technical Product Specification*
- **System BIOS/Firmware and Security Updates: Intel® Server Board M50FCP2SBSTD**
 - System Update Package (SUP): uEFI only
<http://downloadcenter.intel.com>
- **Intel® Solid State Drive (SSD) Secure Data Deletion and Firmware Updates**
 - **Note:** for system configurations that may be configured with an Intel SSD
 - Intel® Solid State Drive Toolbox
<https://downloadcenter.intel.com/product/35125/Memory-and-Storage>
- **Intel® RAID Controller Firmware Updates and other support collaterals**
 - **Note:** for system configurations that may be configured with an Intel® RAID Controller
<https://www.intel.com/content/www/us/en/support/products/43732/server-products/raid-products.html>

² An L9 system configuration is a power-on ready server system with NO operating system installed.

An L6 system configuration requires additional components to be installed to make it power-on ready. L3 are component building block options that require integration into a chassis to create a functional server system

EU Directive 2019/424 (Lot 9) – Support Summary

A template to report information needed for (EU) 2019/424 (Lot 9) server conformity assessment. The information provided herein does not represent any final shipping server system test results, and customer's actual test results for shipping server configurations may differ from this list. Use of this information is at the sole risk of the user, and Intel assumes no responsibility for customers server system level regulation compliance to EU 2019/424 (Lot 9).

Product Information																
Product Type	Server															
Manufacturer Name	Intel Corporation															
Registered trade name and address	Intel 2200 Mission College Blvd, Santa Clara, CA 95054-1594, USA															
Product model number and model numbers for low end performance and high-end performance configure if applicable	M500001UR															
Year Of Launch	2023															
PSU efficiency at 10%, 20%, 50% and 100% of rated output power	AXX1300TCRPS(PSSF132202A) - 1300W AC Titanium AXX1600TCRPS (PSSF162205A) – 1600W AC Titanium <table border="1" data-bbox="740 726 1442 831"> <thead> <tr> <th>Model</th> <th>10%</th> <th>20%</th> <th>50%</th> <th>100%</th> </tr> </thead> <tbody> <tr> <td>AXX1300TCRPS</td> <td>92.77%</td> <td>95.47%</td> <td>96.01%</td> <td>94.21%</td> </tr> <tr> <td>AXX1600TCRPS</td> <td>90.95%</td> <td>94.57%</td> <td>96.25%</td> <td>95.15%</td> </tr> </tbody> </table>	Model	10%	20%	50%	100%	AXX1300TCRPS	92.77%	95.47%	96.01%	94.21%	AXX1600TCRPS	90.95%	94.57%	96.25%	95.15%
Model	10%	20%	50%	100%												
AXX1300TCRPS	92.77%	95.47%	96.01%	94.21%												
AXX1600TCRPS	90.95%	94.57%	96.25%	95.15%												
PSU factor at 50% of rated load level	>0.99 (PSSF132202A) 0.99 (PSSF162205A)															
PSU Rated Power Output (Server Only)	1300W (PSSF132202A) 1600W (PSSF162205A)															
Idle state power (Server only) (Watts)	Refer to the following table															
List of all components for additional idle power allowances (server only)	Refer to the following table															
Maximum power (Server only)	Refer to the following table															
Declared operating condition class	Class A2 – Continuous Operation. 10°C to 35°C with the maximum rate of change not to exceed 10°C per hour.															
Idle State Power (watts) at the higher boundary temp (Server Only)	Refer to the following table															
the active state efficiency and the performance in active state of the server (server only)	Refer to the following table															
Information on the secure data deletion functionality	Refer to the following table															
for blade server, a list of recommended combinations with compatible chassis (Server only)	Not Applicable															
If Product Model Is Part Of A Server Product Family, a list of all model configurations that are represented by the model shall be supplied (Server only)	Not Applicable															

Energy Efficiency Data of M500001UR – 1 (Single) Processor Installed Configurations

Configuration			1 CPU Low-end Config.	1 CPU High-end Config.
Details	Chassis	Model	M500001UR	
	Node/MB	Quantity	1	1
		Model	M50FCP	M50FCP
	CPU	Quantity	1	1
		Model	“Sapphire Rapids” Intel® Xeon® Gold 5415+	“Sapphire Rapids” Intel® Xeon® Platinum 8458P
	Memory	Quantity	8 per Node	8 per Node
		Capacity per DIMM (GB)	16GB	16GB
		Total Memory Amount (GB)	128 GB	128 GB
	SSD	SSD Quantity	2	2
	PSU	Quantity	1	1
Model		AXX1300TCRPS	AXX1300TCRPS	
FW		BIOS: SE5C7411.86B.8713.D03 FRU: 0.0.3 BMC: V1.25 Windows Server 2019*	BIOS: SE5C7411.86B.8424.D03 FRU: 0.0.3 BMC: V1.19 Windows Server 2019	
Measured and Calculated Server Allowance	P Base		25	25
	Additional CPU		59.4	250.2
	Additional Power Supply		0	0
	Storage Devices		10	10
	Additional Memory		22.32	22.32
	Additional I/O Device (10Gx 15W/2Port on MB)		0	0
	Perfcpu		5.94	25.02
Limits/ Results	Idle power allowances (W)		116.7	307.5
	Idle power tested (W) Per node		108.2	127.6
	Minimum Eff _{ACTIVE}		9	9
	Eff _{ACTIVE} tested		31.2	55.8
Other test result	Idle Power at Higher Temp. (per Node) @ 35 °C		124.4	146.2
	Max Power (W Per Node)		235.8	499.9

Energy Efficiency Data of M500001UR – 2 (Dual) Processors Installed Configuration

Configuration			2 CPUs Low-end Config.	2 CPUs High-end Config.
Details	Chassis	Model	M500001UR	
	Node/MB	Quantity	1	1
		Model	M50FCP	M50FCP
	CPU	Quantity	2	2
		Model	“Sapphire Rapids” Intel® Xeon® Gold 5415+	“Sapphire Rapids” Intel® Xeon® Platinum 8458P
	Memory	Quantity	16 per Node	16 per Node
		Capacity per DIMM (GB)	16GB	16 GB
		Total Memory Amount (GB)	256 GB	256 GB
	SSD	SSD Quantity	2	2
	PSU	Quantity	2	2
Model		AXX1300TCRPS	AXX1300TCRPS	
FW		BIOS: SE5C7411.86B.8713.D03 FRU: 0.0.3 BMC: V1.25 Windows Server 2019*	BIOS: SE5C7411.86B.8424.D03 FRU: 0.0.3 BMC: V1.19 Windows Server 2019	
Measured and Calculated Server Allowance	P Base		38	38
	Additional CPU		76.6	336.6
	Additional Power Supply		10	10
	Storage Devices		10	10
	Additional Memory		45.36	45.36
	Additional I/O Device (10Gx 15W/2Port on MB)		0	0
	Perfcpu		10.94	48.08
Limits/ Results	Idle power allowances (W)		179.9	440
	Idle power tested (W) Per node		170.5	219.6
	Minimum Eff _{ACTIVE}		9.5	9.5
	Eff _{ACTIVE} tested		30.6	58
Other test result	Idle Power at Higher Temp. (per Node) @ 35 degree C		187.1	237.7
	Max Power (W Per Node)		431.7	917

Other Information:

Chemical Declaration
<ul style="list-style-type: none"> • Neodymium Not Applicable. (No HDD offered by Intel) • Cobalt Not Applicable. (No BBUs. Coin battery is out of scope)

Appendix H. Glossary

Term	Definition
ACPI	Advanced Configuration and Power Interface
ARP	Address Resolution Protocol
ASHRAE	American Society of Heating, Refrigerating and Air-Conditioning Engineers
BBS	BIOS boot selection
BMC	Baseboard management controller
BIOS	Basic input/output system
CFM	Cubic feet per minute
CMOS	Complementary metal-oxide-semiconductor
CPU	Central processing unit
CXL	Compute Express Link
DDR5	Double data rate 5
DHCP	Dynamic Host Configuration Protocol
DIMM	Dual in-line memory module
DPC	DIMMs per channel
EDS	External design specification
EFI	Extensible firmware interface
EPS	External product specification
EVAC	Enhanced volume air cooling
FP	Front panel
FRB	Fault resilient boot
FRU	Field replaceable unit
GPGPU	General purpose graphic processing unit
GPIO	General purpose input/output
GUI	Graphical user interface
I²C	Inter-integrated circuit bus
IMC	Integrated memory controller
IIO	Integrated input/output
iPC	Intel product code
IPMI	Intelligent Platform Management Interface
ISTA	International Safe Transit Association
KVM	Keyboard, video, and mouse
JRE	Java Runtime Environment
LED	Light emitting diode
LFM	Linear feet per minute: airflow measurement
LPC	Low-pin count
LRDIMM	Load reduced DIMM
LSB	Least significant bit
Memory Module	DDR5 DIMM is commonly referred to as “memory module”
MKTME	Multi-key Total Memory Encryption
MLE	Measured launched environment
MM	Memory mode
MRC	Memory reference code
MSB	Most significant bit
MTBF	Mean time between failure
NAT	Network address translation
NIC	Network interface controller
NMI	Non-maskable interrupt
NTB	Non-transparent bridge
NVMe*	Non-Volatile Memory Express* is an optimized, high-performance scalable storage interface designed to address the needs of enterprise systems that use PCIe-based solid-state storage. NVMe* provides efficient access to non-volatile memory storage devices. NVMe* allows host hardware and software to take advantage of the levels of parallelism possible in modern SSDs.
OEM	Original equipment manufacturer
OCP*	Open Compute Project
OR	Oct (8) rank

Term	Definition
OTP	Over temperature protection
OVP	Over-voltage protection
PCH	Peripheral controller hub
PCI	Peripheral component interconnect
PCB	Printed circuit board
PCIe*	Peripheral Component Interconnect Express*
PECI	Platform Environment Control Interface
PFC	Power factor correction
Intel® PFR	Intel® Platform Firmware Resilience
PHM	Processor heat sink module
PMBus*	Power Management Bus*
PMem	Persistent memory module
POST	Power-on self-test
PSU	Power supply unit
PWM	Pulse width modulation
QR	Quad rank
RAID	Redundant array of independent disks
RAM	Random access memory
RAS	Reliability, availability, and serviceability
RCiEP	Root complex integrated endpoint
RDIMM	Registered DIMM
RGMII	Reduced Gigabit Media Independent Interface
ROC	RAID on CPU
SAS	Serial Attached SCSI
SATA	Serial Advanced Technology Attachment
SCA	Single Connector Attachment
SCSI	Small computer system interface
SDR	Sensor data record
SEL	System event log
SFF	Small form factor
SFP	Small form-factor pluggable
SFUP	System firmware update package
Intel® SGX	Intel® Software Guard Extensions
SMBus	System Management Bus
SMTP	Simple mail transfer protocol
SNMP	Simple Network Management Protocol
SOL	Serial-over-LAN
SR	Single rank
SSD	Solid state device
SSH	Secure shell
TCG	Trusted Computing Group
TDP	Thermal design power
TIM	Thermal interface material
Intel® TME	Intel® Total Memory Encryption (Intel® TME)
Intel® TME-MK	Intel® Total Memory Encryption – Multi-Key (Intel® TME-MK)
TPM	Trusted platform module
TPS	Technical product specification
Intel® TXT	Intel® Trusted Execution Technology
Intel® TDX	Intel® Trust Domain Extension
UEFI	Unified Extensible Firmware Interface
Intel® UPI	Intel® Ultra Path Interconnect
VLSI	Very large scale integration
Intel® VMD	Intel® Volume Management Device
VR	Voltage regulator
VSB	Voltage standby
Intel® VROC	Intel® Virtual RAID on CPU
Intel® VT-d	Intel® Virtualization Technology for Directed I/O

Term	Definition
Intel® VT-x	Intel® Virtualization Technology for IA-32, Intel® 64 and Intel® Architecture